

# CSB1 D13 HxA

## OPERATING INSTRUCTIONS



**NORTON**  
SAINT-GOBAIN®

**clipper®**



# Declaration of conformity

The undersigned manufacturer:

**SAINT - GOBAIN ABRASIVES S.A.**  
**190, BD J.F. KENNEDY**  
**L- 4930 BASCHARAGE**

Declares that this product:

Floor saw (Code):

**CSB1 D13 HIA ( 70184613925)**

**CSB1 D13 HMA ( 70184613926)**

is in conformity with the following Directives:

- ***European Machinery Directive 2006/42/EC***
- ***Electromagnetic Compatibility Directive 2004/108/EC***

and European standard:

- ***EN 13862 – Floor cutting-off machines – Safety***

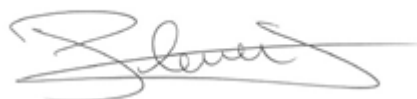

Olivier Plenert  
Machine Design Manager



# CSB1 D13 HxA HATZ

## OPERATING INSTRUCTIONS

<b><u>1</u></b>	<b><u>Basic Safety Instructions</u></b>	<b><u>6</u></b>
1.1	<i>Symbols</i>	6
1.2	<i>Machine plate</i>	7
1.3	<i>Safety instructions for particular operating phases</i>	7
<b><u>2</u></b>	<b><u>General description of the CSB1 D13</u></b>	<b><u>9</u></b>
2.1	<i>Short description</i>	9
2.2	<i>Layout</i>	9
2.3	<i>Technical data</i>	11
<b><u>3</u></b>	<b><u>Assembly and commissioning</u></b>	<b><u>12</u></b>
3.1	<i>Tool assembly</i>	12
3.2	<i>Water cooling system</i>	12
3.3	<i>Starting the machine</i>	13
<b><u>4</u></b>	<b><u>Transport and Storing</u></b>	<b><u>15</u></b>
4.1	<i>Securing for transport</i>	15
4.2	<i>Transport procedure</i>	15
4.3	<i>Long period of inactivity</i>	15
<b><u>5</u></b>	<b><u>Operating the CSB1 D13</u></b>	<b><u>16</u></b>
5.1	<i>Site of work</i>	16
5.2	<i>Cutting method</i>	16
<b><u>6</u></b>	<b><u>Maintenance and service</u></b>	<b><u>17</u></b>
6.1	<i>Maintenance of the machine</i>	17
6.2	<i>Maintenance of the engine</i>	18
<b><u>7</u></b>	<b><u>Faults: causes and cures</u></b>	<b><u>21</u></b>
7.1	<i>Fault-finding procedures</i>	21
7.2	<i>Trouble-shooting guide</i>	21
7.3	<i>Customer service</i>	22

# 1 Basic Safety Instructions

The CSB1 D13 is exclusively designed for the cutting of floors made of asphalt, green and cured concrete (reinforced or not) as well as of industrial cement.

Uses other than the manufacturer's instructions shall be considered as contravening the regulations. The manufacturer shall not be held responsible for any resulting damage. Any risk shall be borne entirely by the user. Observing the operating instructions and compliance with inspection and servicing requirements shall also be considered as included under use in accordance with the regulations.

## 1.1 Symbols

Important warnings and pieces of advice are indicated on the machine using symbols. The following symbols are used on the machine:

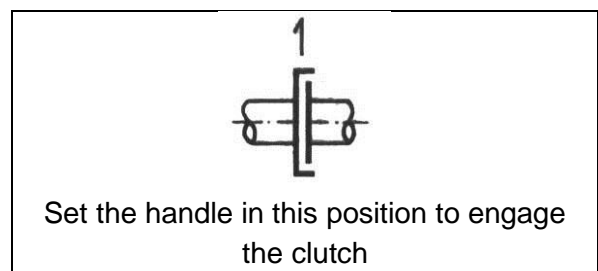
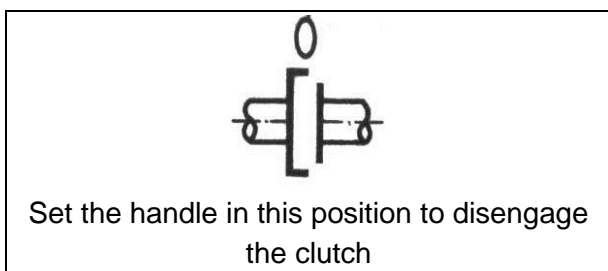
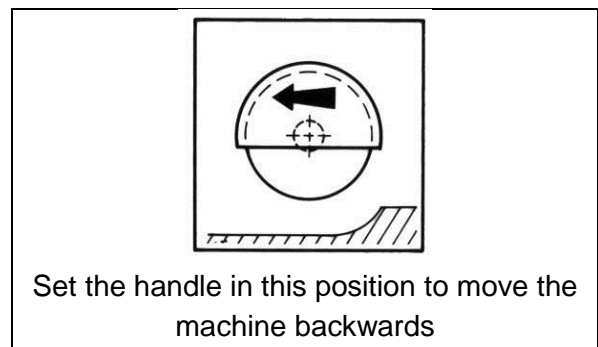
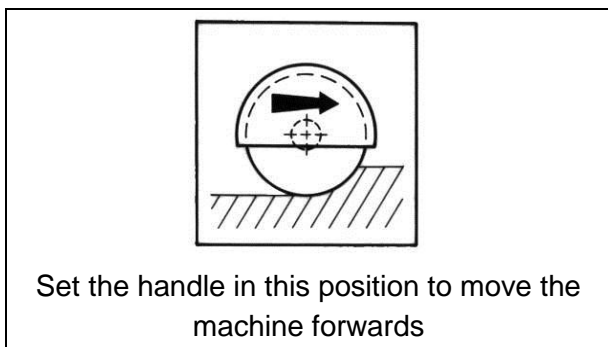
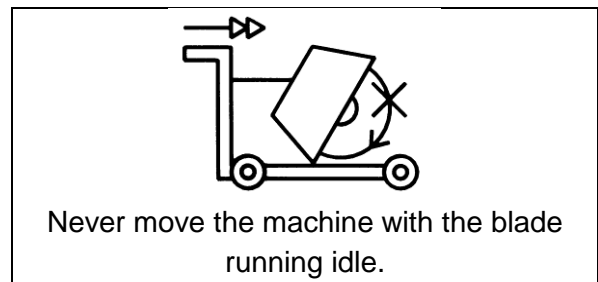
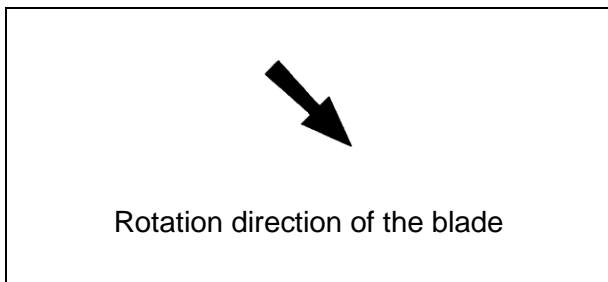
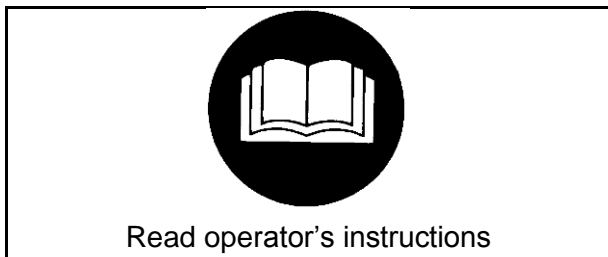

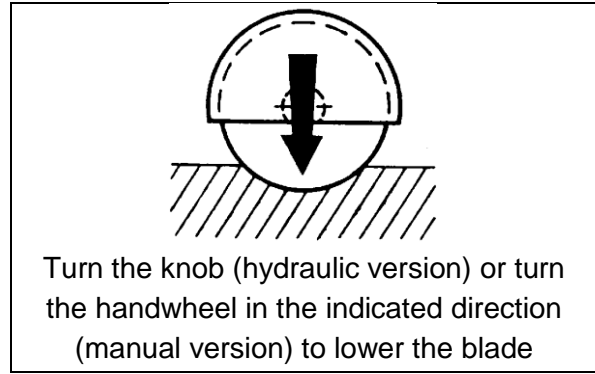
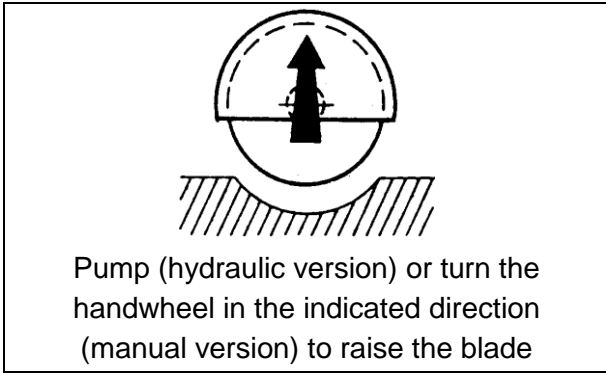

## 1.2 Machine plate

Important data can be found on the following plate located on the machine:

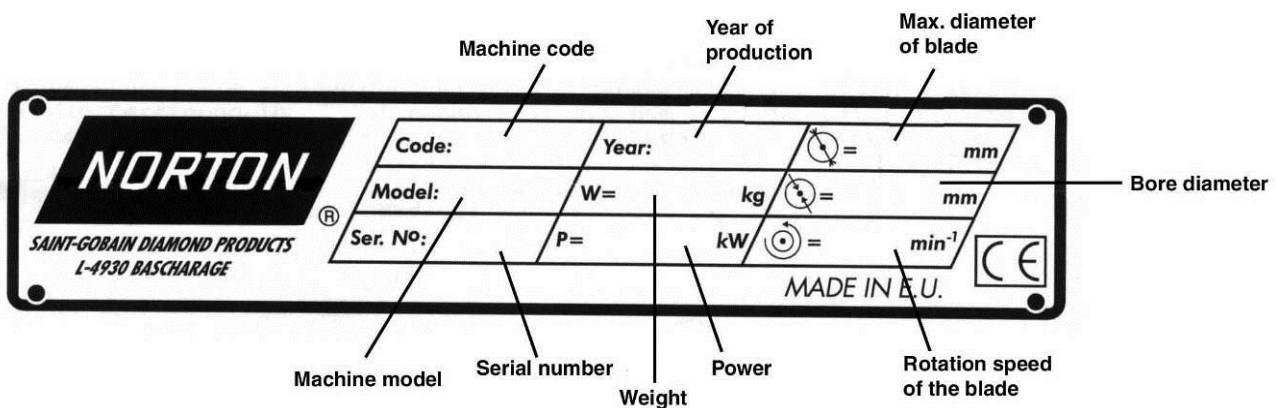

## 1.3 Safety instructions for particular operating phases

### Before commencing work

- Before commencing work, make yourself familiar with the working environment at the place of use. The working environment includes: obstacles in the area of work and manoeuvre, the firmness of the floor, necessary protection at the site relating to public thoroughfares and the availability of help in the event of accidents.
- Check for correct mounting of the blade regularly.
- Immediately remove damaged or badly worn blades, as they endanger the operator whilst rotating.
- Always cut with the blade guard in position.
- Only fit NORTON diamond blades to the machine! The use of other tools can damage the machine!
- Attention is drawn to the use of BS2092 safety goggles in conformity with specified Processes No.8 of the Protection of Eyes Regulation 1974, Regulation 2(2) Part 1.
- For security reasons, never leave the machine unattended, untied or unlocked.

**While the engine is running**

- Do not move the machine whilst the blade is running idle.
- Do not run the machine without the security guards in place.
- Apply cooling water continuously whilst cutting and in good time!

**Diesel powered machines:**

- Always use the fuel advised.
- In confined areas, exhaust gases should be evacuated and the job site properly aerated.
- Diesel machines, which by their nature emit toxic exhaust gases, must not be used in places prohibited by the Health at Work Act 1974 or which are prohibited by Factory Inspectors or Safety Officers.
- Diesel is flammable. Before filling the tank, shut down the engine, extinguish all open flames and do not smoke. Take care that no diesel is spilled on any motor part. Always wipe up spilled fuel.



## 2 General description of the CSB1 D13

Any modification, which could lead to a change in the original characteristics of the machine, may be done only by Saint-Gobain Abrasives S.A. who shall confirm that the machine is still in conformity with the safety regulations. Saint-Gobain Abrasives S.A. keeps the right of making technical or design modification without prior notification.

### 2.1 Short description

The **Floor Saw CSB1 D13** you have chosen is used for repair works in concrete and asphalt on highways and runways, for trench sawing or cable loop cutting applications. It can be used for either wet or dry cutting operations.

It can be easily transported in a van. The limited width of machine allows precision cuts in the tightest of situations.

All component parts on the **CSB1 D13** are assembled to a high quality standard, ensuring long life, reliability and a minimum of maintenance.

Special types of blades are available for asphalt, green concrete, cured concrete (reinforced or not) as well as for industrial cement flooring.

### 2.2 Layout

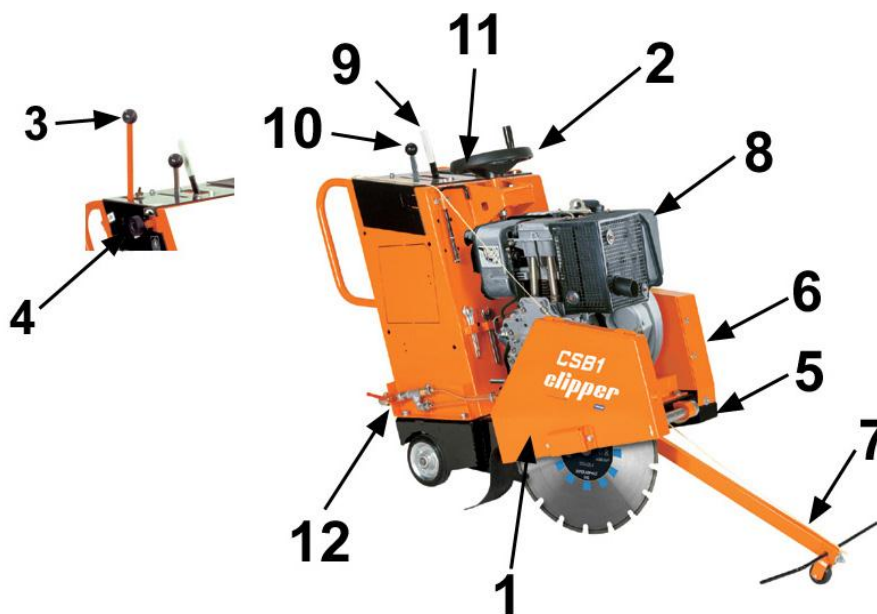

Made of jig welded open profile steel, the **CSB1 D13** is stable but at the same time, easily transportable.

The blade guard (1) fully protects the operator and his working environment. It is firmly fixed to the main frame but can be opened to change blades.

The machine exists in two different types: hydraulic and manual. On the manual machines, a handwheel (2) enables graduated depth setting. On the hydraulic machines, a manually operated hydraulic pump (3) enables graduated depth setting. Pumping on the handle will raise the blade, using the knob (4) on the side of the machine will lower the blade.

The pivoting frame (5), hinged on the rear axle, is supporting the engine, the blade shaft assembly, and the protecting guards. Four heavy-duty belts drive the blade.

The precisely manufactured blade shaft is fitted into two heavy-duty self-aligning pillow block bearings. A pulley is fitted on one end. The shaft is reduced to 25,4mm at the other end, allowing an inner flange complete with dowel pinholes to be fixed.

The steel belt guard (6) is bolted to the mainframe of the machine. It is covering the five drive belts and pulleys for protection of the environment while the machine is running.

The pointer (7) allows the operator to make precise cut easily.

The machine can be moved back and forward through a hydrostatic drive device. The clutch is engaged or disengaged using the handle (9). The direction and speed of movement is regulated using the handle (10).

The water cooling system is composed of a 25 litres water tank (11), a water tank tap (12) and two water nozzles on the blade guard ensuring adequate flow of water to both sides of the blade. External water supply may also be used by connecting to the palm coupling.

The HATZ 1D81Z diesel engine (8) is connected to a speed regulation handle on the right hand side of the machine. This handle is also used to shut the machine down in case of emergency. The following picture is showing the different parts of your engine that you need to know in order to use and maintain your machine correctly:

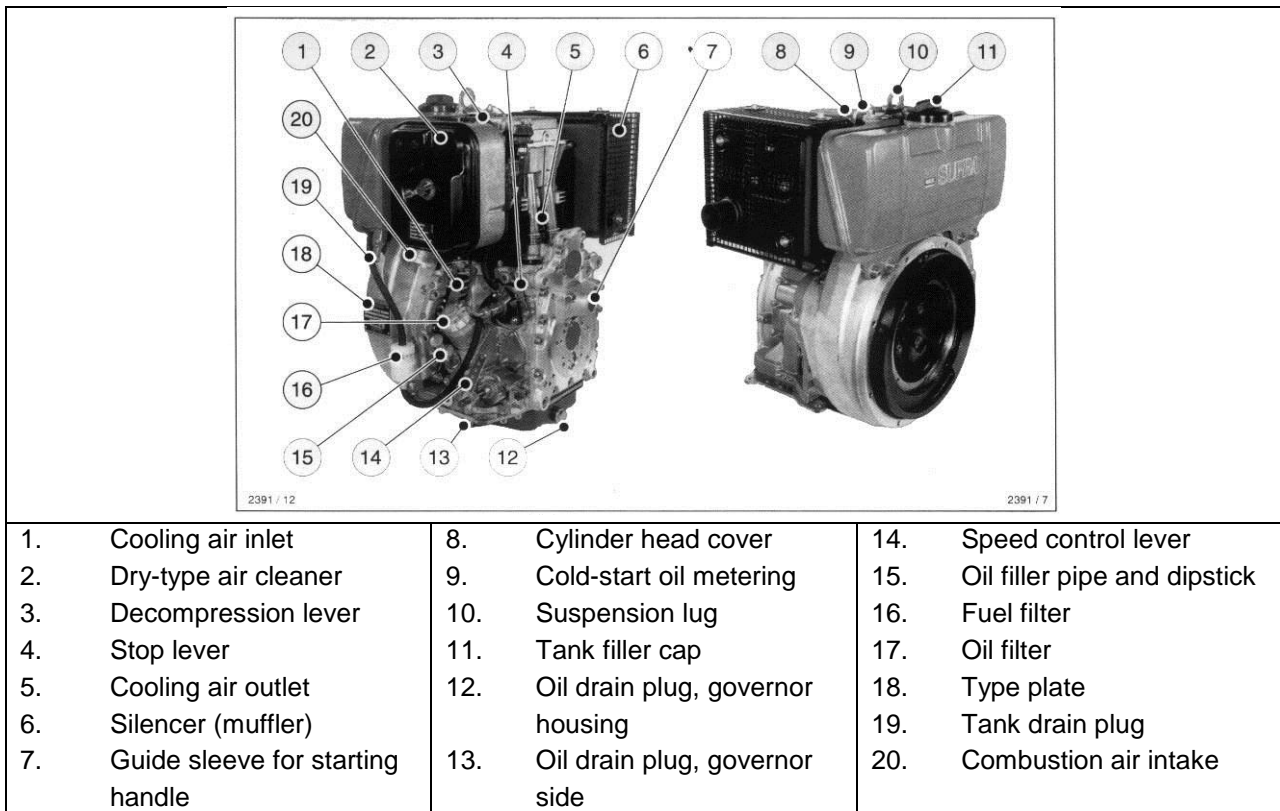

### 2.3 Technical data

Engine	Hatz 1D81Z, 13HP (9,5kW)
Fuel	Diesel complying with the following minimum specifications : <b>EN590</b> or <b>DIN15601 – DK</b> or <b>BS 2869 A1/A2</b> or <b>ASTM D975 – 1D / 2D</b>
Oil (Motor)	Oil complying with the following minimum specifications: <b>CCMC – D4 – D5 – PD2</b> or <b>API – CD – CE – CF – CG</b> or <b>SHPD</b> Viscosity recommended : SAE 10W-30 (outside temperature between -5°C and 35°C)
Oil (Hydrostatic and hydraulic raise system (option))	Hydraulic oil with a viscosity equivalent to the one of an automotive oil SAE 20W-20
Starter	Handle with kick-back damping
Blade raise system	Manual (Machine with code 70184613926) Hydraulic (Machine with code 70184613925 and 70184613879)
Max. blade diameter	500 mm
Bore	25,4 mm
Max. cutting depth mm	190 mm
Flange diameter	108 mm
Blade shaft speed	1950 min <sup>-1</sup>
Driving belts	5
Water tank	40 l
Machine dimensions (length x width x height)	1200x600x1040mm
Weight	260 kg
Max. operating weight	310 kg
Sound pressure level	101 dB (A) following ISO EN 11201
Sound energy level	114 dB (A) following ISO EN 3744

### **3 Assembly and commissioning**

Before beginning the work with the CSB1 D13, you have to assemble some parts.

#### **3.1 Tool assembly**

Only use NORTON blades with the CSB1 D13.

A blade with a maximum diameter of 500 mm can be fitted. All tools used must be selected with regard to their maximum permitted cutting speed for the machine's maximum permitted rotation speed.

Before mounting a new blade, switch the machine off.

To mount a new blade, follow these steps:

- Pump (for hydraulic machines) or turn the handwheel (for manual machines) until the cutting head is in the raised position.
- Take the water nozzle off the blade guard.
- Loosen the two screws maintaining the blade guard with the 19mm wrench, and open it.
- Loosen the screw holding the removable outer flange with the 19mm wrench.
- Remove the outer flange.
- Clean the flanges and blade shaft and inspect for wear.
- Mount the blade on the shaft ensuring that direction of rotation is correct. Wrong direction of rotation blunts the blade quickly.
- Replace outer blade flange.
- Tighten screw with 19mm wrench.
- Close the blade guard and retighten the two screws.
- Reconnect water nozzle.

The blade bore must correspond exactly to the blade shaft. Cracked or damaged bore is dangerous for the operator and for the machine.

#### **3.2 Water cooling system**

Fill the water tank with clean water.

Open water-tap (note that handle on water-tap should be in line with water-flow).

Ensure that water is flowing freely in the circuit and delivered adequately to both sides of the blade, as insufficient water supply may result in premature failure of the diamond blade.

In case of frost, empty the water cooling system.

### 3.3 Starting the machine

Make sure the blade is raised clear up the ground before starting the machine, and that the clutch is disengaged.

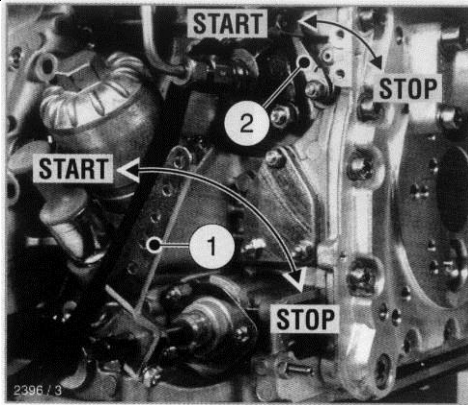

Set the control lever "1" to a position between ½ START and max. START, according to requirements. Selecting a lower engine speed will reduce smoke when starting. Also make sure that the speed lever on the side of the machine is in opposite to STOP.

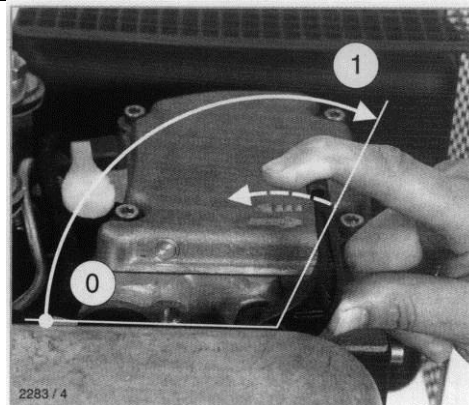

Turn the decompression lever until stop "1" is reached. In this position you can hear the automatic decompression system engage.

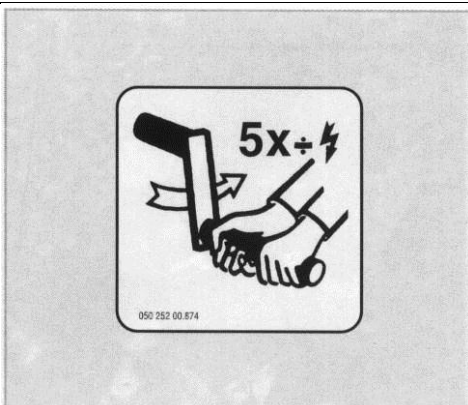

After the automatic decompression device has engaged at its limit stop, turn the crank five times to build up compression.

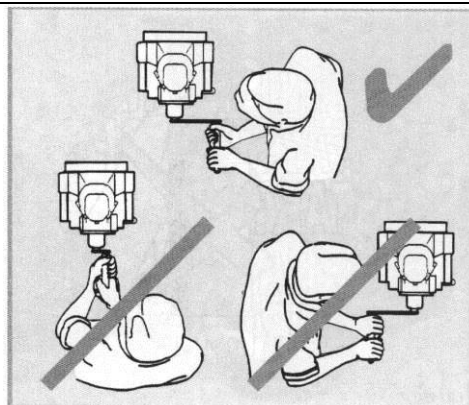

Position yourself on the side of the machine, following the drawing. Always hold the tubular grip with both hands. Turn the handle slowly until the pawl engages in the ratchet, then increase turning force to build up speed. The highest speed must be reached when the decompression lever returns to the "0" position. As soon as the engine has started, pull the starting handle out of the guide sleeve.

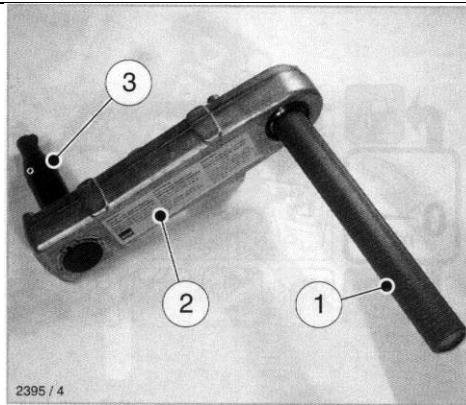

You must hold the tubular grip firmly to maintain contact all the time between the starting handle and the engine. Maintain turning force during the entire hand starting operation.

If backfiring occurs when starting the engine because the crank handle was not turned firmly enough, the brief reverse rotation at the handle tube separates the link between crank lug "2" and driving dog "3".

If the engine begins to run backwards after backfiring (smoke emerges from air cleaner), release the crank handle immediately and stop the engine.

To restart the engine, wait until it has come to a standstill, then repeat the starting preparations.

## **4 Transport and Storing**

Take the following measures in order to transport and store the CSB1 D13 securely.

### **4.1 Securing for transport**

Before transporting the machine:

- Remove the blade.
- Empty the water tank.
- Raise the guide-a-cut in its upright position.
- Raise the cutting frame to its highest position.
- Take the key off the starter.

### **4.2 Transport procedure**

The machine can be moved on a flat surface using its wheels. You have two possibilities:

- Disengage the clutch of the machine and push it without starting the motor.
- Make sure the clutch is disengaged and then start the engine. Make sure the speed handle is in middle position, then engage the clutch and use the speed handle to move the machine backwards or forwards, and to regulate the speed.

Use the metal lifting eye, located above the engine when lifting the CSB1 with a crane. This lifting eye must not be used to lift the saw if the blade is stuck in the cut.

### **4.3 Long period of inactivity**

If the machine is not going to be used for a long period, please take the following measures:

- Completely clean the machine.
- Loosen the drive belts.
- Change the motor oil.
- Empty the water system.

The storage site must be clean, dry and at a constant temperature.

## 5 Operating the CSB1 D13

### 5.1 Site of work

Before you start working, please check the following points:

- Remove from the site anything, which might hinder the working procedure.
- Make sure the site is sufficiently well lit.
- Make sure you have a continual adequate view of the working area so you can intervene in the working process at any time.
- Keep other staff out of the area, so you can work securely.

### 5.2 Cutting method

In this section, you can find instructions to make a straight cut at the desired depth.

#### 5.2.1 Preparing your cut

Before starting the machine,

- Draw a line on the floor over the cutting length.
- Make sure you have filled the engine tank with fuel, and the water tank with water, or that you have connected the blade guard to the water supply. No diesel is supplied with the machine.
- The engine is shipped with oil. Check oil level before starting. Top up if required.
- Make sure you have mounted the correct blade as recommended by the manufacturer depending on the material to be worked, the working procedure (dry or wet cut) to be carried out, and the efficiency required.
- Make sure that the flanges securely hold the diamond blade.
- Make sure that the blade is not touching the floor before starting the engine.
- Roll the machine until the blade is over the line.
- Lower the guide-a-cut so it touches the line.
- Set the speed handle in the middle position, so that if you engage the clutch, the machine will not move unexpectedly. Make also sure that the clutch is disengaged.

#### 5.2.2 Cutting the floor

You can now start the engine.

To make your cut,

- Lower the pivoting frame until the blade slightly touches the floor.
- Open water valve to control the amount of water required for the type of blade, using 15 to 25l/min for wet and 1-2l/min for dry cutting, dust control. Check for minimum water level regularly.
- Lower blade into the cut. Once the required depth of cut is reached, you can engage the clutch and use the back and forward handle to regulate speed. Always cut with the machine moving forward, as cutting backwards will damage the blade and the blade shaft. Follow the line with the pointer. The feed speed must be adjusted depending on the material being cut, and depth of cut.
- At the end of the cut, raise the blade out of the cut, switch off the engine and shut-off the water.



## 6 Maintenance and service

**ATTENTION** : to perform maintenance on the machine, always switch it off.

### 6.1 Maintenance of the machine

To ensure a long-term quality from the cutting with the CSB1 D13, please follow the maintenance plan below:

Regular service period Perform at every indicated period →		After one hour of work	Begin of the day	During the changing of the tool	End of the day	Every week	After a fault	After a damage
		Whole machine	Visual control (general aspect, watertightness)					
	Clean							
Oil (hydrostatic)	Control and refill							
Flange and blade fixing devices	Clean							
Belts tension	Control							
Water hoses and nozzles	Clean							
Depth screw (manual machines)	Grease							
Engine housing	Clean							
Reachable nuts and screws	Tighten up							

#### Adjustment and replacement of the belts

After one hour of work, the belts heat and stretch. Therefore, you have to re-tension them.

To adjust the belts, firstly remove the belt guard by unscrewing the 3 screws with the 17mm wrench. Loose the screw maintaining the tensioning device with the 19mm wrench. You can know re-tension using a 36mm wrench to turn the tensioning device. Retighten the maintaining screw, and re-assemble the belt guard.

To replace the belts, loose the screw maintaining the tensioning device and turn the tensioning device in order to release the belts. Adjust the belts and retighten them by moving the tensioning device back on the belts with the 36mm wrench then retighten the maintaining screw of the tensioning device.

Always use a matched set of belts. Do not replace single belts. After controlling or retightening the belts, reassemble the belt guard on the frame of the machine.

#### Lubrication

The CSB1 D13 uses life-lubricated bearings. Therefore, you don't need to lubricate them at all.

At the beginning of a working day, check the level of oil in your hydrostatic transmission. You must have 1 cm of oil in the oil container over the hydrostatic transmission. Do not fill more than 1 cm, otherwise you will damage this device.

If you have an oil link on the hydraulic raise system (hydraulic machines only), eliminate the problem (for example by changing the joints), and refill with the recommended oil.

#### Cleaning of the machine

Your machine will last longer if you clean it thoroughly after each day of work.

## 6.2 Maintenance of the engine

		Regular service period Perform operating hour interval			
		Each use	First month or 25 hours	Every 250 hours	Every 500 hours
Engine oil	Check level				
	Change				
Cooling air zone	Check-Clean				
Air intake point	Check-Clean				
Water trap	Check				
Air cleaner filter	Clean				
	Change the cartridge				
Valve clearance	Check and adjust				
Fuel filter	Replace				

### Oil level check

When checking the oil level, the engine must not be running, and should stand horizontal.

- Remove any dirt in the dipstick area.
- Check oil level at the dipstick: top up if necessary as far as the max. mark.

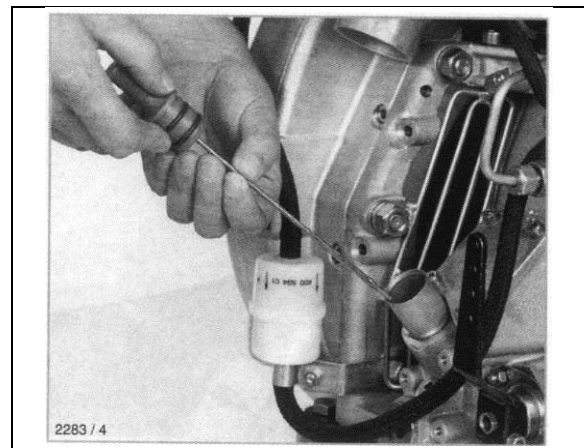

### Changing engine oil

The engine must be stopped, and should stand horizontal. Drain the engine oil when its warm.

**CAUTION!** Risk of scalding from hot oil.

Please dispose of used motor oil in a manner that is compatible with the environment. We suggest you to take used oil in a sealed container to your local recycling centre or service station for reclamation. Do not throw it in the trash, pour it on the ground or down in a drain.

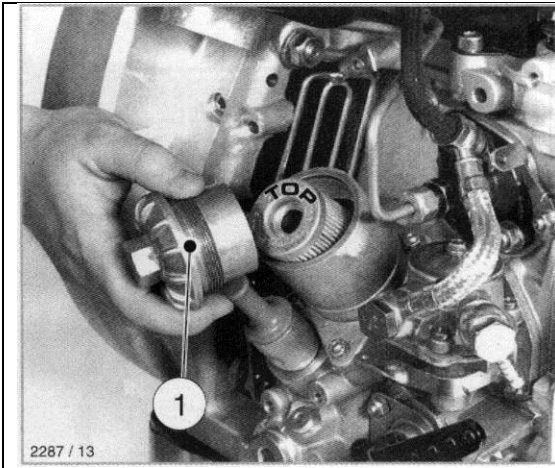

- Unscrew the oil drain plug and allow all the oil to drain out.
- Clean the oil drain plug and attach a new seal. Insert and tighten the plug.
- Renew the replaceable lubricating oil filter element (left picture).
- Clean sieve bottom carefully in order not to bend the netting (right picture). Wipe out cap screw or blow it out with compressed air.
- Note the TOP mark on the oil filter.
- Check condition of O-Ring "1" and renew it if necessary.
- Wet the thread and the O-Ring of the screw plug with lubricant "K"
- Add engine oil up to the MAX mark on the dipstick
- Run the engine for a short period, then check the oil level again and top up if necessary.
- Check that there is no leakage past screw plug on the oil filter.

### Checking the water trap

The intervals at which you check the water trap depend entirely on the amount of water in the fuel and the care taken when refuelling. However, you should check it at least once a week.

- Loosen the hexagonal screw "1" with approx. 2-3 rotations.
- Trap the drops which emerge in a transparent vessel. Since water has a greater specific gravity than diesel fuel, the water emerges before the diesel fuel. The two substances separate at a clearly visible line.
- As soon as diesel only emerges, retighten screw "1".

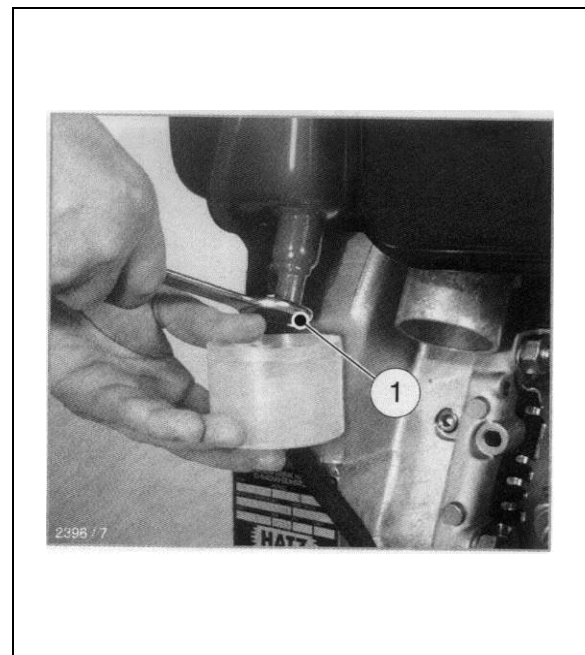

## Cleaning of the cooling air system

Before cleaning, the engine must be stopped and allowed to cool down.

- Remove parts of air duct.
- Clean all air guide elements and the complete cooling air zones on the cylinder head, cylinder and flywheel blades without making them wet. Blow them with compressed air.
- In case of moist or oily contamination, clean the complete area with a solvent, cold cleaner etc. according to its manufacturer's instructions, then spray down with a powerful water jet. Do not point the spray directly at electrical equipment or connections, or dry these immediately afterwards with compressed air.
- Trace the cause of any contamination with oil and have the leak eliminated by a HATZ service station.
- Install the air guide elements previously removed. The engine must never be run without the air guide elements in position.
- Immediately after re-assembly, run the engine until warm to prevent residual moisture from causing rust.

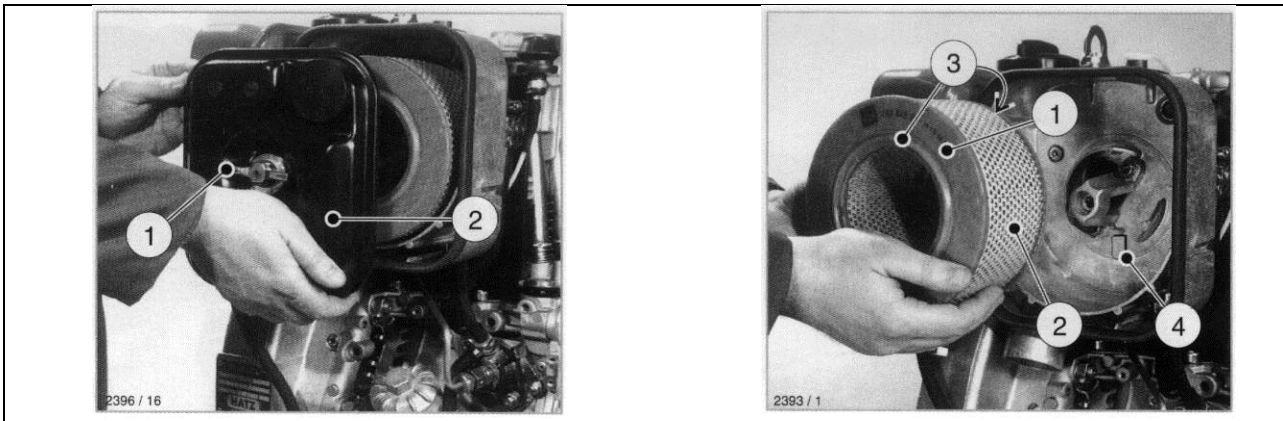

### Cleaning the filter cartridge

- Slacken off wing bolt (1 on left picture) and remove it with cover (2 on left picture).
- Carefully pull out filter cartridge (1 on right picture)
- Clean all parts except the filter cartridge. Do not spray into the engine's air intake when cleaning.
- Blow through the filter cartridge from the inside, moving the jet of dry compressed air up and down until no further dust is expelled. Air pressure must not exceed 5 bar.
- Tilt the cartridge and hold it against the light (or shine a light through it) to trace any cracks or other damage.  
**If there is even the slightest damage to paper filter element „2“ or sealing lips „3“, the filter element must not be reused.**
- By wet or oily contamination, change the cartridge.

### Checking of the valve clearance and of the fuel filter

Contact a HATZ-Service station to make this maintenance.

## 7 Faults: causes and cures

### 7.1 Fault-finding procedures

Should any fault occur during the use of the machine, turn it off. Let only qualified staff make any intervention other than the one described in the previous section.

### 7.2 Trouble-shooting guide

Trouble	Possible source	Resolution
Engine fires but stops again as soon as the crank is disengaged	No oil pressure	Check the oil level
	Cylinder head temperature too high	Check cooling air passage
	Stronger fault	Contact nearest engine maintenance centre
Engine lacks power	Tank run dry	Add fuel
	Air filter restricted	Clean or replace air filter
	Speed control lever does not remain in the selected position	Prevent speed control from moving
	Stronger fault	Contact nearest engine maintenance centre
Engine stops by itself during regular operation	Tank run dry	Add fuel
	Air filter restricted	Clean or replace air filter
	No oil pressure	Check the oil level
	Stronger fault	Contact nearest engine maintenance centre

### **7.3 Customer service**

When ordering spare parts, please mention:

- The serial number (seven digits or a letter and 6 digits).
- The code of the part.
- The exact denomination.
- The number of parts required.
- The delivery address.
- Please indicate clearly the means of transportation required such as "express" or "by air". Without specific instructions, we will forward the parts through the means which seem appropriate to us and but which is not always the quickest way.

Clear instructions will avoid problems and faulty deliveries.

If not sure, please send us the defective part.

In the case of a warranty is claim, the part must always be returned for evaluation.

Spare parts for the engine can be ordered with the manufacturer of the engine or with their dealer, which is often quicker and cheaper.

This machine has been manufactured by Saint-Gobain Abrasives S.A.

190, rue J.F.Kennedy

L- 4930 BASCHARAGE

Grand-Duché de Luxembourg.

Tel. : 00352-50401-1

Fax : 00352- 50 16 33

<http://www.norton-diamond.com>

Guarantee can be claimed and technical support obtained from your local distributor where machines, spare parts and consumables can be ordered as well:

#### **Benelux and France:**

From Saint-Gobain Abrasives  
in the Grand-Duché de Luxembourg

Free telephone numbers:

Belgium : 0 800 18951

France: 0 800 90 69 03

Holland: 0 8000 22 02 70

e-mail: [sales.nlx@saint-gobain.com](mailto:sales.nlx@saint-gobain.com)

#### **Germany**

Saint-Gobain Diamond Products GmbH  
Birkenweg 45-49,

D-50389 WESSELING

Tel : (02236) 8911 0

Fax : (02236) 8911 30

e-mail: [sales.ngg@saint-gobain.com](mailto:sales.ngg@saint-gobain.com)

#### **Spain**

Saint-Gobain Abrasivos S.A.

Ctra Guipuzcoa km7,5

31195 BERRIOPLANO (Navarra)

Tel: 0034 948 30 3000

Fax: 0034 948 30 6042

e-mail : [Comercial.sga-apa@saint-gobain.com](mailto:Comercial.sga-apa@saint-gobain.com)

#### **Hungary**

Saint-Gobain Abrasives KFT.

Budafoki u. 111

H-1117 BUDAPEST

Tel: ++36 1 371 2250

Fax: ++36 1 371 2255

e-mail: [nortonbp@axelero.hu](mailto:nortonbp@axelero.hu)

#### **Czech Republic**

Norton Diamantove Nastroje Sro

Vinohradska 184

CS-13000 PRAHA 3

Tel: 0042 0267 13 20 21

Fax: 0042 0267 13 20 21

e-mail: [norton.diamonds@komerce.cz](mailto:norton.diamonds@komerce.cz)

#### **United Kingdom**

Saint-Gobain Abrasives Ltd.

Unit 2, meridian West

Meridian Business Park

Leicester

LE19 1WX

Tel : 0116 2632 302

Fax : 0800 622 385

e-mail : [nortondiamonduk@saint-gobain.com](mailto:nortondiamonduk@saint-gobain.com)

#### **Italy**

Saint-Gobain Abrasivi S.p.A.

Via per Cesano Boscone, 4

I-20094 CORSICO-MILANO

Tel: 0039 02 44 851

Fax: 0039 0245 101238

e-mail: [Norton.edilizia@saint-gobain.com](mailto:Norton.edilizia@saint-gobain.com)

#### **Austria**

Saint-Gobain Abrasives GmbH

Telsenberggasse 37,

A-5020 SALZBURG

Tel: 0043 662 43 00 76 77

Fax: 0043 662 43 01 75

e-mail: [office@sga.net](mailto:office@sga.net)

#### **Poland**

Saint-Gobain Diamond Products Sp.zO.O.

AL. Krakowska 110/114

PL-00-971 WARSZAWA

Tel: 0048 22 868 29 36

Tel/Fax: 0048 22 868 29 27

e-mail: [norton-diamond@wp.pl](mailto:norton-diamond@wp.pl)

[www.construction.norton.eu](http://www.construction.norton.eu)

**Saint-Gobain Abrasives**

190, Bd. J. F. Kennedy  
L-4930 BASCHARAGE  
LUXEMBOURG

Tel: ++352 50401-1

Fax: ++352 501633

e-mail: [sales.nlx@saint-gobain.com](mailto:sales.nlx@saint-gobain.com)