

# CT 901 MP

## OPERATING INSTRUCTIONS

Translation of the original instructions







# Declaration of conformity

The undersigned manufacturer:

**SAINT - GOBAIN ABRASIVES S.A.  
190, BD. J. F. KENNEDY  
L-4930 BASCHARAGE**

Declares that this product:

Power Float: **CT 901 MP**

Code : **70184629948**

is in conformity with the following Directives:

- **"MACHINES" 2006/42/CE**
- **"ÉLECTROMAGNÉTIQUE COMPATIBILITÉ" 2004/108/CE**
- **"NOISE" 2000/14/CE**

And the European standard

- **EN 12649 – Concrete compactors and resurfacing**

Valid for machines as of serial number:

70100000

Storage site for the technical documents :

Saint-Gobain Abrasives 190, Bd. J. F. Kennedy 4930 BASCHARAGE, LUXEMBOURG

This declaration of conformity loses its validity when the product is converted or modified without agreement.

Bascharage, Luxembourg, 01/02/2012

Olivier Plenert, executive officer.



# CT 901 MP

## OPERATING INSTRUCTIONS AND SPARE PARTS LIST

<b><u>1</u></b>	<b><u>Basic Safety Instructions</u></b>	<b><u>6</u></b>
1.1	<i>Symbols</i>	6
1.2	<i>Machine plate</i>	7
1.3	<i>Safety instructions for particular operating phases</i>	7
<b><u>2</u></b>	<b><u>Machine description</u></b>	<b><u>8</u></b>
2.1	<i>Short description</i>	8
2.2	<i>Purpose of use</i>	8
2.3	<i>Layout</i>	8
2.4	<i>Technical Data</i>	9
2.5	<i>Statement regarding the vibration emission</i>	10
2.6	<i>Statement regarding noise emission</i>	11
<b><u>3</u></b>	<b><u>Assembly and commissioning</u></b>	<b><u>12</u></b>
3.1	<i>Handle</i>	12
3.2	<i>Tool assembly</i>	12
3.3	<i>Starting the machine</i>	13
<b><u>4</u></b>	<b><u>Transport and storing</u></b>	<b><u>14</u></b>
4.1	<i>Securing for transport</i>	14
4.2	<i>Transport procedure</i>	14
4.3	<i>Long period of inactivity</i>	14
<b><u>5</u></b>	<b><u>Operating the machine</u></b>	<b><u>15</u></b>
5.1	<i>Site of work</i>	15
5.2	<i>Preparing the site</i>	15
5.3	<i>Floating and finishing operation</i>	15
<b><u>6</u></b>	<b><u>Maintenance and servicing</u></b>	<b><u>17</u></b>
6.1	<i>Maintenance of the machine</i>	17
6.2	<i>Maintenance of the engine</i>	17
<b><u>7</u></b>	<b><u>Faults: causes and cures</u></b>	<b><u>21</u></b>
7.1	<i>Fault-finding procedures</i>	21
7.2	<i>Trouble-shooting guide</i>	21
7.3	<i>Customer service</i>	22

# 1 BASIC SAFETY INSTRUCTIONS

The CT901MP is exclusively designed for the finishing of wet concrete floors mainly on construction sites.

Uses other than the manufacturer's instructions shall be considered as contravening the regulations. The manufacturer shall not be held responsible for any resulting damage. Any risk shall be borne entirely by the user. Observing the operating instructions and compliance with inspection and servicing requirements shall also be considered as included under use in accordance with the regulations.

## 1.1 Symbols

Important warnings and pieces of advice are indicated on the machine using symbols. The following symbols are used on the machine:



Read operator's instructions



Ear protection and safety goggles must be worn

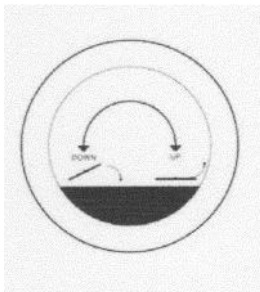

Turn the knob in the indicated direction to tilt (UP) or flatten (DOWN) the blades.



To prevent severe injuries, keep the feet and fingers away from the rotating tool

## 1.2 Machine plate

Important data can be found on the following plate located on the machine:

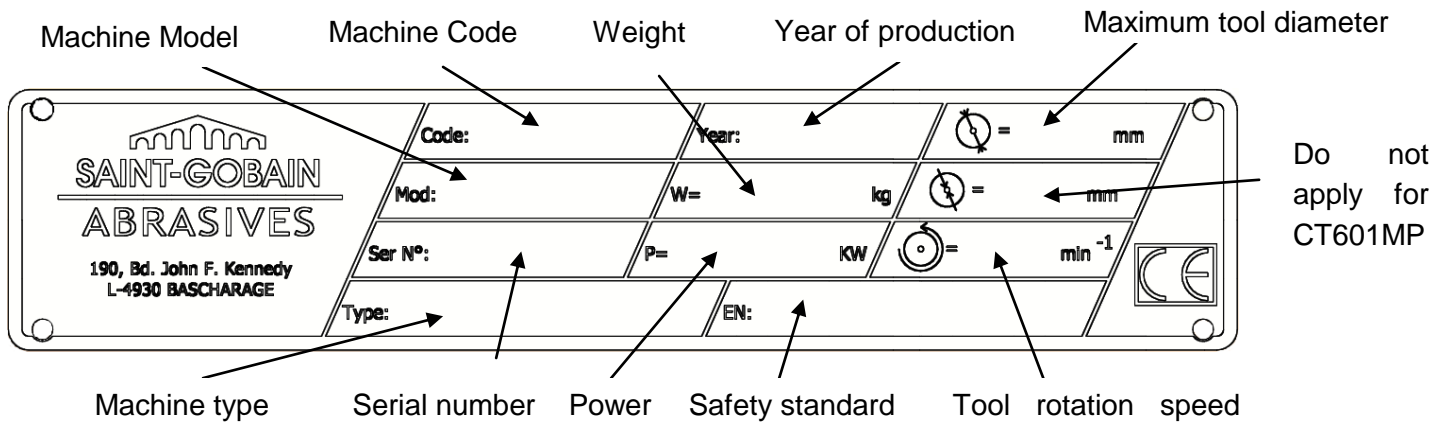

## 1.3 Safety instructions for particular operating phases

### Before commencing work

- Read the present operator's instructions booklet carefully.
- Before commencing work, make yourself familiar with the working environment at the place of use. The working environment includes: obstacles in the area of work and manoeuvre, the firmness of the floor, necessary protection at the site relating to public thoroughfares and the availability of help in the event of accidents.
- Check for correct mounting of the tool regularly.
- Immediately remove damaged or badly worn tools, as they endanger the operator whilst rotating.
- Always use the machine with the safety guard ring and protection guards in position.
- Only fit NORTON blades or plates to the machine! The use of other tools can damage the machine!
- Attention is drawn to the use of BS2092 safety goggles in conformity with specified Processes No.8 of the Protection of Eyes Regulation 1974, Regulation 2(2) Part 1.

### Petrol powered machines:

- Always use the fuel advised.
- In confined areas, exhaust gases should be evacuated and the job site properly aerated.
- Petrol machines, which by their nature emit toxic exhaust gases, must not be used in places prohibited by the Health at Work etc. Act 1974 or which are prohibited by Factory Inspectors or Safety Officers.
- Fuel is flammable. Before filling the tank, shut down the engine, extinguish all open flames and do not smoke. Take care that no petrol is spilled on any engine part. Always wipe up spilled fuel.

## 2 MACHINE DESCRIPTION

Any modification, which could lead to a change in the original characteristics of the machine, may be done only by Saint-Gobain Abrasives who shall confirm that the machine is still in conformity with the safety regulations.

### 2.1 Short description

The Mechanical Trowel CT901MP is designed for durability and high performance for onsite finishing operations on wet concrete floors.

As with all other NORTON products, the operator will immediately appreciate the attention given to detail and quality of materials used in construction. The machine and its component parts are assembled to high standards assuring long life and minimum maintenance.

### 2.2 Purpose of use

The Clipper Mechanical Trowel CT901MP is designed for onsite finishing operations on wet concrete floors. It is not designed for any other purpose.

### 2.3 Layout



#### Handle (1)

Jig welded steel construction including 2 rubber grips. A dead-man handle (7) allows the operator to work safely and to stop the machine at any moment. The angle of the machine arm can be adjusted to operate the machine comfortably. A tube (8) is located under the handle, this will help you transport the machine per hand.



**Pitch of the blades (2)**

The pitch of the blades is controlled over a knob on the handle.

**Belt drive and belt cover (3)**

A centrifugal clutch inside the engine pulley drives the gear shaft through V-Belts. It allows to gradually engage the tool rotation. The drive assembly is enclosed in a metal guard.

**Safety guard ring (4)**

A safety guard ring protects the operator from the rotation of the tool while offering an optimum view of the working progress.

**Thermal Engine (5)**

The machine has a GX200 Honda engine, with 4,8kW. The dead-man handle (7) allows an immediate stop of the machine in case of danger.

**Lifting eye (6)**

To lift the machine easily and safely, a lifting eye is located over the engine. This allows a balanced lifting of the machine.

**2.4 Technical Data**

Engine	Honda GX200, 4 strokes, 1 cylinder, 6,5HP (4,8kW)
Filter	Dual Filter
Fuel	Regular unleaded
Oil	Honda 4-Stroke, or equivalent high detergent, premium quality motor oil certified to meet or exceed U.S. automobile manufacturer's requirement for service classification SG, SF. (SG, SF designated on the oil container). SAE 10W-30 recommended
Starter	Manual pull chord
Type of spark plug	BPR6ES (NGK) W20EPR-U (DENSO)
Type of tool	Blade or plate
Max. tool diameter	900 mm
Blade shaft speed	130 min <sup>-1</sup>
Machine dimensions	1980x950x1060 mm
Max. operating weight	81 kg
Sound pressure level	85 dB (A) (ISO EN 11201)
Sound energy level	94 dB (A) (ISO EN 3744)

## 2.5 Statement regarding the vibration emission

Declared value of vibration emission following **EN 12096**.

Machine Model / code	Measured value of vibration emission at $m/s^2$	Uncertainty K $m/s^2$	Tool used Model / code
CT 901 MP 70184629948	<2.5	0.5	Original Pale

- The vibration value is lower and does not exceed 2.5  $m/s^2$ .
- Values determined using the procedure described in the standard **EN 12649**.
- The measurements are made with new machines. Actual values may vary with site conditions, in terms of:
  - Materials worked
  - Wear Machine
  - Lack of maintenance
  - Inappropriate tool for application
  - Tool in poor condition
  - Unskilled operator
  - Etc...
- The exposure time to vibration is based on the performance of work (related to the adequacy Machine / Tool / worked material / operator)
- When evaluating risks due to hand-arm vibration, you need to take into account effective usage at rated power of machine during a full day of work; quite often you will realise that effective utilisation time represents around 50% of overall duration of work. You have to consider, of course, breaks, water feeding, preparation of work, time to move the machine, disk mounting...

## 2.6 Statement regarding noise emission

Declared value of noise emission following **EN ISO 11201** and **NF EN ISO 3744**.

Machine Model / code	Sound Pressure level $L_{Peq}$ EN ISO 11201	Uncertainty K (Sound Pressure level $L_{Peq}$ EN ISO 11201)	Sound power level $L_{Weq}$ NF EN ISO 3744	Uncertainty K (Sound power level $L_{Weq}$ NF EN ISO 3744)
<b>CT 901 MP</b> 70184629948	85 dB(A)	2.5 dB(A)	94 dB(A)	4 dB(A)

- Values determined using the procedure described in the standard **EN 12649**.
- The measurements are made with new machines. Actual values may vary with site conditions, in terms of:
  - Wear Machine
  - Lack of maintenance
  - Inappropriate tool for application
  - Tool in poor condition
  - Unskilled operator
  - Etc...
- Measured values relate to an operator in normal use, as described in the manual position.

### **3 ASSEMBLY AND COMMISSIONING**

The machine is delivered fully equipped. It is ready for operation after assembly of the tool and adjustment of the machine arm, and after connection to the appropriate power supply.

#### **3.1 Handle**

Set the machine arm in a comfortable position. To that purpose, loosen the handle on the arm and set the arm at the right angle, then retighten the handle.

#### **3.2 Tool assembly**

Only NORTON blades or plate with a maximum diameter of 900 mm can be used with the CT901MP.

Before mounting a new tool into the machine, switch off the machine and make sure the tools are not rotating anymore.

Screw 2 M6-screws per blade using a 10mm wrench to assemble the blade on the arm. To assemble a plate, place the machine with the blades assembled on the plate, and turn it until the blades are located in the hooks on the plate.

### 3.3 Starting the machine

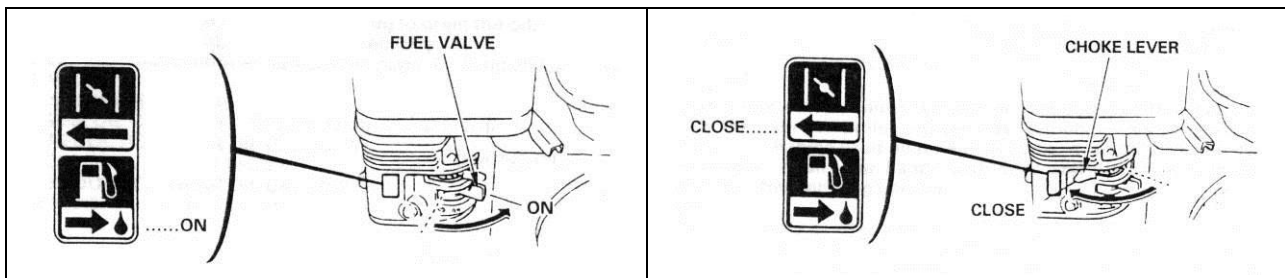

Turn the fuel valve to the ON position. Fully press the dead-man handle against the main handle.

Move the choke lever to the CLOSED position. NOTE: do not use the choke if the engine is warm or the air temperature is high.

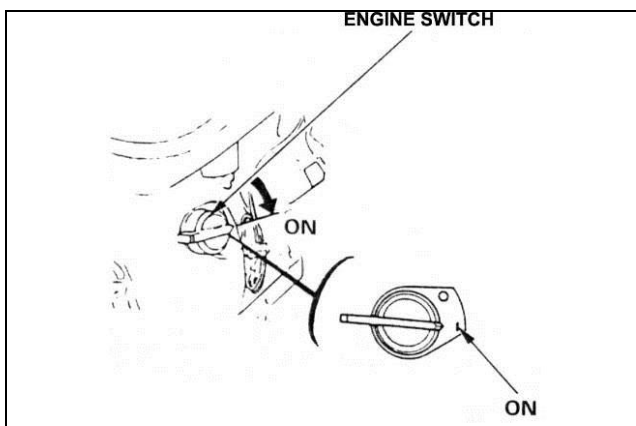

Move the throttle control lever slightly to the left. Put the engine switch on ON.

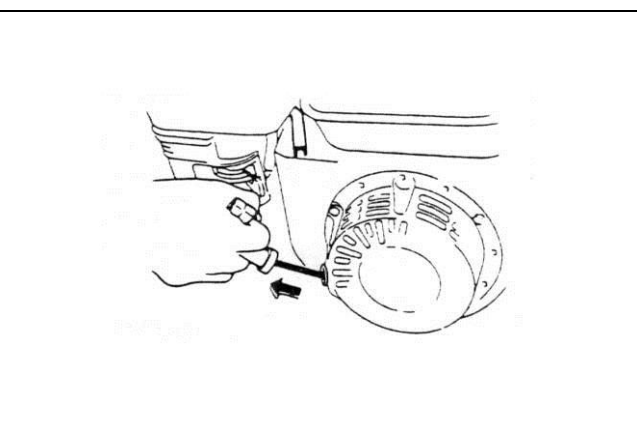

Pull the starter grip lightly until you feel resistance, then pull briskly. CAUTION: Do not allow the starter grip to snap back against the engine. Return it gently to prevent damage to the starter.

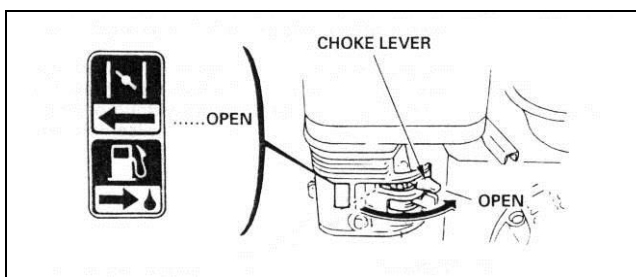

As the engine warms up, gradually move the choke lever to the OPEN position. Position the throttle control lever for the maximum engine speed.

To stop the engine, release the dead-man handle, move the throttle control lever fully to the right, then turn the engine switch to the OFF position. Turn the fuel valve to the OFF position.

CAUTION: when the machine is switched off, the tools will continue turning slowly to complete stop. Be therefore very careful to avoid injuries.

## 4 TRANSPORT AND STORING

### 4.1 *Securing for transport*

Before transporting the machine, always remove the blades and the plate.

### 4.2 *Transport procedure*

Conform yourself to work regulations, in order to transport the machine safely. To help you transport the machine, you can remove the transport tube from under the handle and located in the front hole of the machine (see picture below).



To lift the machine, use the lifting eye. Make sure that your lifting device is securely fastened to the lifting eye.

### 4.3 *Long period of inactivity*

If the machine is not going to be used for a long period, completely clean the machine and disassemble the tools. The storage site must be clean, dry and at a constant temperature.

## 5 OPERATING THE MACHINE

### 5.1 Site of work

- Remove from the site anything, which might hinder the working procedure!
- Make sure the site is sufficiently well lit!
- Make sure you have a continual adequate view of the working area so you can intervene in the working process at any time!
- Keep other staff out of the area, so you can work securely.

### 5.2 Preparing the site

Prepare the concrete as for manual trowelling. Assure a well levelled surface (we recommend the use of a beam or better a vibrating screeder). When slab has set sufficiently firm so that the operator can walk on it, leaving only a slight impression (approx.3mm), it is ready for the floating operation.

### 5.3 Floating and finishing operation

To use the machine correctly, you must face it with the two hands on the handle.

#### Handling the machine

Operate the machine from right to left as shown in the following drawing:

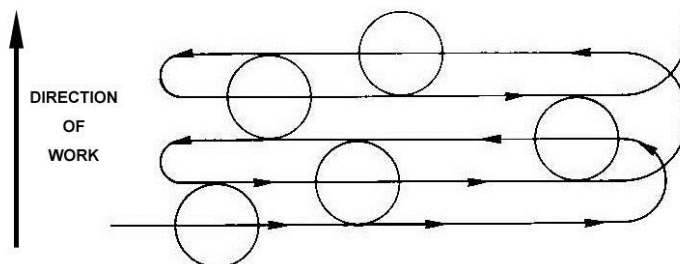

To move the machine:

- Forward (I on the following drawing), turn the handle clockwise.
- Backward (II), turn the handle counterclockwise.
- To the left (III), pull up the handle.
- To the right (IV), push down the handle.

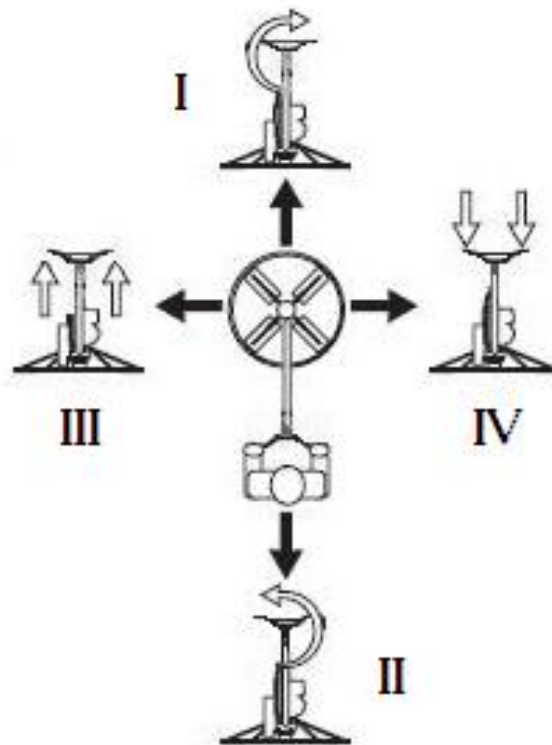

### Tilting the blades

Floating the slab is done with the blades nearly flat on the surface of the concrete; however it is recommended that the blades are just slightly tilted to avoid the suction and drag created in normal operation of float blades on wet concrete. For the finishing operation, tilt the blades. Start with a small pitch of 4 to 6 mm. After each finishing pass, continue to tilt blades.

### Depression or high spot

To fill a depression or cut down a high spot, simply move the machine back and forward over the area until the desired surface is obtained.

**IMPORTANT:** Do not allow the machine to stand in one spot on wet concrete – remove the machine from the slab when it is not used.

**CAUTION:** when the machine is switched off, the tools will continue turning slowly to complete stop. Be therefore very careful to avoid injuries.



## 6 MAINTENANCE AND SERVICING

### 6.1 Maintenance of the machine

To ensure a long-term quality from the use of the CT901MP, please follow the maintenance plan below:

		Begin of the day	During the changing of tool	End of the day or more often if required	Every week	After a fault	After a damage
Whole machine	Visual control (general aspect, water tightness)						
	Clean						
Surface of blades or plate	Clean						
Tension of the blade	Check						
Engine housing	Clean						
Reachable nuts and screws	Tighten up						

#### Maintenance of the machine

Always perform the maintenance with the machine switched off and the tools idle.

#### Lubrication

The CT901MP uses life-lubricated bearings. Therefore, you don't need to lubricate the machine at all.

#### Control and change of the belt

To control the tension of belts, open the belt guard, and push on the belts. You should be able to gape the belt as thick as a finger. If the tension is incorrect, adjust the belt tension by stalling the engine. Make sure that the pulleys are aligned before tightening the mounting nuts from the engine. To change the belt, open the housing, remove the old belt and install a new on the pulleys. Make sure that the pulleys are aligned before tightening the mounting nuts from the engine. After the control or change the belts, always reassemble the belt guard.

#### Cleaning of the machine

Your machine will last longer if you clean it thoroughly after each day of work, especially engine and blades or pan.

### 6.2 Maintenance of the engine

		Regular service period			
		Each use	First month or 20 hours	Every 3 months or 50 hours	Every 6 months or 100 hours
Perform at every indicated month or operating hour interval, whichever comes first →					
Engine oil	Check level				
	Change				
Air cleaner filter	Check				
	Clean				
Fuel strainer cup	Clean				
Spark plug	Check-Clean				
Fuel line	Check (Replace if necessary)	Every 2 years			

**Engine oil**

To change the oil,

- Remove the oil filler cap/dipstick and drain bolt.
- Allow the oil to drain completely.
- Dispose of used engine oil in a manner that is compatible with the environment. We suggest you to take used oil in a sealed container to your local recycling centre or service station for reclamation. Do not throw it in the trash, pour it on the ground or down in a drain.
- Reinstall the drain bolt, and tighten it to 18 N.m.
- Fill the crankcase with the engine oil to the outer edge of the oil filler neck.
- Reinstall the filler cap/dipstick.

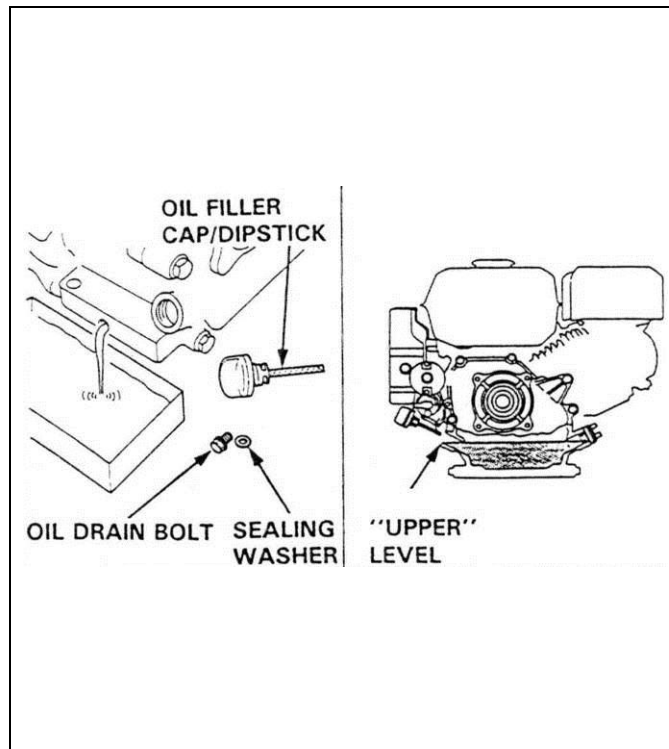

### Air cleaner

To service the air cleaner filter, follow these instructions:

- Remove the nut, air cleaner cover and wing nut.
- Remove the pre air cleaner elements and separate them.
- Carefully check both elements for holes or tears and replace if damaged.
- **Paper element:** tap element lightly several times on a hard surface to remove excess dirt or blow compressed air lightly through the filter from the inside out. Never brush the dirt off; brushing will force dirt into the fibres.
- **Foam element:** clean in warm soapy water, rinse and allow to dry thoroughly. Dip the element in clean engine oil and squeeze out all the excess. The engine will smoke during initial start-up if too much oil is left in the foam.
- Shine a light through the elements, and inspect them carefully. Reinstall the elements if they are free of holes and tears.

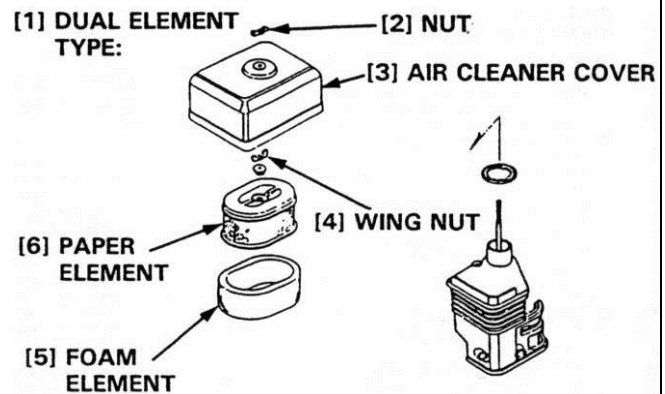

### Fuel strainer cup

To service fuel strainer cup, follow these instructions:

- Turn off the fuel valve and remove the strainer cup.
- Clean the strainer cup with solvent.
- Install the O-ring and strainer cup.
- Tighten the strainer cup to 4N.m.

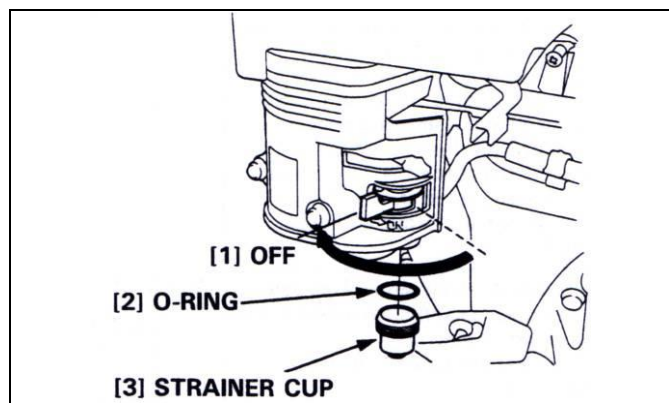

### Spark plug

To service the spark plug, follow these instructions:

- Visually inspect the spark plug. Discard the plug if the insulator is cracked or chipped.
- Remove carbon or other deposits with a stiff wire brush.
- Measure the plug gap with a wire-type feeler gauge. If necessary, adjust the gap by bending the side electrode.
- Make sure the sealing washer is in good condition; replace the plug if necessary.
- Install the plug fingertight to seat the washer, then tighten with a plug wrench (an additional  $\frac{1}{2}$  turn if a new plug) to compress the sealing washer. If you are reusing a plug, tighten  $\frac{1}{8}$ - $\frac{1}{4}$  turn after the plug seats.

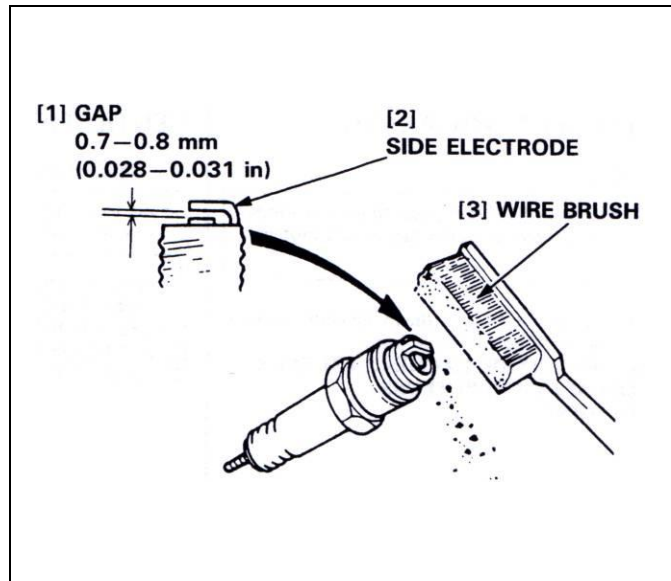

### Fuel line

To service the fuel line, follow these instructions:

- Drain the fuel into a suitable container, and remove the fuel tank.
- Disconnect the fuel line, and unscrew the fuel filter from the tank.
- Clean the filter with solvent, and check, that the filter screen is undamaged.
- Place the O-ring on the filter and reinstall. Tighten the filter to 2N.m. After reassembly, check for fuel leaks.

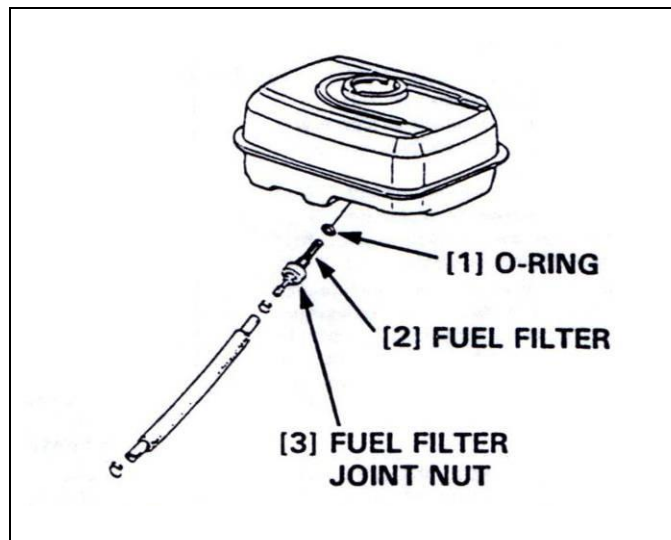

### Further maintenance

For further maintenance, please contact the nearest engine maintenance centre

## 7 FAULTS: CAUSES AND CURES

### 7.1 *Fault-finding procedures*

Should any fault occur during the use of the machine, turn it off. Any works dealing with the engine of the machine can only be carried out by a qualified technician.

### 7.2 *Trouble-shooting guide*

<b>Trouble</b>	<b>Possible source</b>	<b>Resolution</b>
Hard starting	Not enough fuel	Fill fuel tank
	Fuel filter clogged	Clean fuel filter
	Spark plug faulty	Inspect spark plug
	Stronger fault	Contact nearest engine maintenance centre
Engine lacks power	Air filter restricted	Clean or replace air filter
	Stronger fault	Contact nearest engine maintenance centre

### **7.3 Customer service**

When ordering spare parts, please mention:

- The serial number (7 digits).
- The code of the part.
- The exact denomination.
- The number of parts required.
- The delivery address.
- Please indicate clearly the means of transportation required such as "express" or "by air". Without specific instructions, we will forward the parts through the means which seem appropriate to us --- but which is not always the quickest way.

Clear instructions will avoid problems and faulty deliveries.

If not sure, please send us the defective part. In the case of a warranty claim, the part must always be returned for evaluation. Spare parts for the motor can be ordered with the manufacturer of the motor or with their dealer, which is often quicker and cheaper.

This machine has been manufactured by Saint-Gobain Abrasives S.A.

190, Bd. J.F. Kennedy

L- 4930 BASCHARAGE

Grand-Duché de Luxembourg.

Tel.: 00352-50401-1

Fax: 00352- 50 16 33

<http://www.construction.norton.eu>

e-mail: [sales.nlx@saint-gobain.com](mailto:sales.nlx@saint-gobain.com)

Guarantee can be claimed and technical support obtained from your local distributor where machines, spare parts and consumables can be ordered as well:

SAINT-GOBAIN ABRASIVES NV/SA  
INDUSTRIELAAN 129  
1070 ANDERLECHT/BRUSSEL  
BELGIUM  
TEL: +32 (0)2 267 21 00  
FAX: +32 (0)2 267 84 24

SAINT-GOBAIN ABRASIVES, S.R.O.  
POČERNICKÁ 272/96, MALEŠICE  
108 00 PRAHA 10  
CZECH REPUBLIC  
TEL: +420 255 719 326  
FAX: +420 255 719 321

SAINT-GOBAIN ABRASIVES A/S  
ROBERT JACOBSENS VEJ 62A  
2300 KØBENHAVN S  
DENMARK  
TEL: +45 4675 5244

PO BOX 643706  
FORTUNE TOWER OFFICE 2106  
JLT BLOCK C  
(NEXT TO METRO STATION)  
JUMEIRA LAKE TOWER, DUBAI  
UNITED ARAB EMIRATES  
TEL: +971 4 431 5154  
FAX: +971 4 431 5434

SAINT-GOBAIN ABRASIFS  
RUE DE L'AMBASSADEUR - B.P.8  
78 702 CONFLANS CEDEX  
FRANCE  
TEL: +33 (0)1 34 90 40 00  
FAX: +33 (0)1 39 19 89 56

SAINT-GOBAIN ABRASIVES GMBH  
BIRKENSTRASSE 45-49  
D-50389 WESSELING  
GERMANY  
TEL: +49 (0) 2236 703-1  
+49 (0) 2236 8996-0  
+49 (0) 2236 8911-0  
FAX: +49 (0) 2236 703-367  
+49 (0) 2236 8996-10  
+49 (0) 2236 8911-30  
FÜR DEN FACHHANDEL  
ÖSTERREICH  
TEL: +43 (00) 662 430 076

SAINT-GOBAIN ABRASIVES KFT.  
1225 BUDAPEST  
BÁNYALÉG U. 60/B.  
HUNGARY  
TEL: +36 1 371 22 50  
FAX: +36 1 371 22 55

SAINT-GOBAIN ABRASIVI S.P.A  
VIA PER CESANO BOSCONI 4  
I-20094 CORSICO MILANO  
ITALY  
TEL: +39 02 44 851  
FAX: +39 02 44 78 266

SAINT-GOBAIN ABRASIVES S.A.  
190 RUE J.F. KENNEDY  
L-4930 BASCHARAGE  
GRAND DUCHE DE LUXEMBOURG  
TEL: +352 50 401 1  
FAX: +352 50 16 33  
NO. VERT (FRANCE) 0800 906 903

SAINT-GOBAIN ABRASIFS, S.A.  
2 ALLÉE DES FIGUIERS  
AIN SEBÂÂ - CASABLANCA  
MOROCCO  
TEL: +212 5 22 66 57 31  
FAX: +212 5 22 35 09 65

SAINT-GOBAIN ABRASIVES BV  
GROENLOSEWEG 28  
7151 HW EIBERGEN  
P.O. BOX 10  
7150 AA EIBERGEN  
THE NETHERLANDS  
TEL: +31 545 466466  
FAX: +31 545 474605

SAINT-GOBAIN ABRASIVES AS  
POSTBOKS 11, ALNABRU,  
0614 OSLO  
BROBEKKVEIEN 84,  
0582 OSLO  
NORWAY  
TEL: +47 63 87 06 00  
FAX: +47 63 87 06 01

SAINT-GOBAIN HPM POLSKA SP. Z O.O.  
UL. NORTON 1  
62-600 KOŁO  
POLAND  
TEL: +48 63 26 17 100  
FAX: +48 63 27 20 401

SAINT-GOBAIN ABRASIVOS, L. DA  
ZONA INDUSTRIAL DA MAIA  
I-SECTOR VIII, NO. 122  
APARTADO 6050  
4476 - 908 MAIA  
PORTUGAL  
TEL: +351 229 437 940  
FAX: +351 229 437 949

SAINT-GOBAIN GLASS  
BUSINESS UNIT ABRASIVI  
PUNCT DE LUCRU: LOC.VETIS, JUD.  
SATU MARE 447355  
STR. CAREIULUI 11  
PARC INDUSTRIAL RENOVATIO  
ROMANIA  
TEL: 0040-261-839.709  
FAX: 0040-261-839.710

SG HPM RUS  
58, F. ENGELS STR.  
STROENIE 2  
105082 MOSCOW  
RUSSIA  
TEL: +74 955 408 355  
FAX: +74 959 373 224

SAINT-GOBAIN  
ABRASIVES (PTY) LTD  
2 MONTEER ROAD  
ISANDO 1600  
P.O. BOX 67  
SOUTH AFRICA  
TEL: +27 11 961 2000  
FAX: +27 11 961 2184/5

SAINT-GOBAIN ABRASIVOS, S.A.  
CTRA. DE GUIPÚZCOA, KM. 7,5  
E-31195 BERRIOPLANO (NAVARRA)  
SPAIN  
TEL: +34 948 306 000  
FAX: +34 948 306 042

SAINT-GOBAIN ABRASIVES AB  
BOX 495  
SE-191 24 SOLLENTUNA  
SWEDEN  
TEL: +46 8 580 881 00  
FAX: +46 8 580 881 01

SAINT-GOBAIN INOVATIF  
MALZEMELER VE AŞINDIRICI  
SAN. TIC. A.Ş.  
GOLD PLAZA, ALTAY ÇEŞME  
MAHALLESİ, ÖZ SOKAK, NO:19/16  
34843 MALTEPE-ISTANBUL,  
TURKEY  
TEL: 0090-216-217 12 50  
FAX: 0090-216-442 40 74

SAINT-GOBAIN ABRASIVES LTD.  
DOXEY RD  
STAFFORD  
ST16 1EA  
UNITED KINGDOM  
TEL: +44 1785 222 000  
FAX: +44 1785 213 487

[www.construction.norton.eu](http://www.construction.norton.eu)

**Saint-Gobain Abrasives**

190, Bd. J. F. Kennedy  
L-4930 BASCHARAGE  
LUXEMBOURG

Tel: ++352 50401-1

Fax: ++352 501633

e-mail: sales.nlx@saint-gobain.com