

NORTON

SAINT-GOBAIN

clipper[®]

Transforming
surfaces
...and beyond

CG 450 UNO

SPARE PART LIST

LISTE DE PIECES DE RECHANGE

ERSATZTEILLISTE



SAINT-GOBAIN

ENGLISH

TYPE:

S = Spare part

W = Wear part

NA = Not Available

The kits of spare parts contain all screws and bolts and the components referring itself to it.

Screws and bolts is component of standard assembly, which you can easily find at all the retailers of standard components of assembly.

All the components of standard assembly are of a quality grade 8.8.

We recommend not to use a quality grade lower than 8.8 for all the standard components of assembly.

The parts of replacements Norton CLIPPER must always be used.

Wear parts life will vary based on usage and maintenance of the machine or part. Wear parts will need to be maintained and replaced as needed. No warranty is applied to wear parts.

The components NA (Not Available) are not available in spare part.

FRANCAIS

TYPE :

S = Pièce de rechange

W = Pièce d'usure

NA = Non disponible

Les kits de pièces détachées contiennent toute la visserie et les composants s'y rapportant.

La visserie est un composant d'assemblage standard, que vous pouvez facilement trouver chez tous les détaillants de composants d'assemblage standards.

Tous les composants d'assemblage standard sont d'une classe de qualité 8.8.

Nous recommandons de ne pas utiliser une classe de qualité inférieure à 8.8 pour tous les composants d'assemblage standards.

Pour les pièces non standard, les pièces de remplacement doivent impérativement provenir de Norton CLIPPER.

La durée de vie des pièces d'usure varie en fonction de l'utilisation et de la maintenance de la machine ou de la pièce. Les pièces d'usure devront être entretenues et remplacées au besoin. Aucune garantie n'est appliquée aux pièces d'usure.

Les composants NA (Not Available) ne sont pas disponibles en pièce de rechange.

DEUTSCH

TYP:

S = Ersatzteile

W = Verschleißteile

NA = nicht verfügbare

Die definierten Ersatzteil-Set's beinhalten alle Ersatzteile wie Komponenten, Schrauben, Muttern etc.

Norm- bzw. Standardteile wie Schrauben, Muttern etc. können bei offiziellen Schrauben- sowie Komponentenhändler bezogen werden.

Alle Norm- bzw. Standardteile wie Schrauben, Muttern etc. entsprechen der Qualitäts- bzw. Festigungsklasse 8.8.

Wir empfehlen, keine Norm- bzw. Standardteile wie Schrauben, Muttern etc. unter der Qualitäts- bzw.

Festigungsklasse 8.8 einzusetzen.

Es dürfen nur geprüfte Norton CLIPPER-Ersatzteile eingesetzt werden.

Die Lebensdauer der Verschleißteile hängt von der Verwendung und Wartung der Maschine oder des Teils ab. Verschleißteile müssen gewartet und bei Bedarf ersetzt werden. Für Verschleißteile wird keine Garantie übernommen.

Ersatzteile sowie Komponenten mit dem Vermerk NA (NA=nicht verfügbar) sind nicht verfügbar.

CG 450 UNO

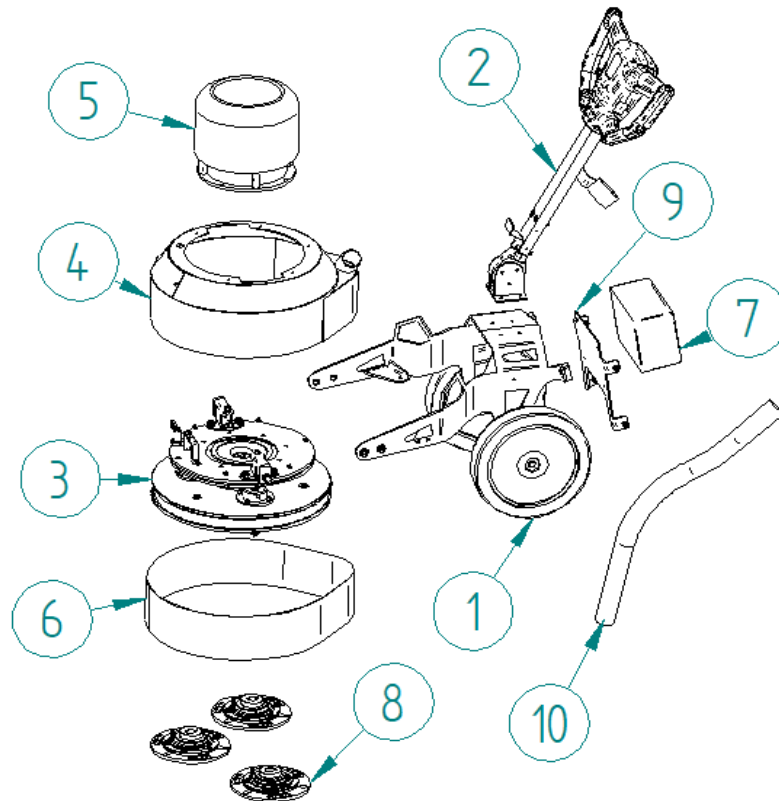

POS.	DESCRIPTION	DESCRIPTION	BESCHREIBUNG	QTY	REF	TYPE
1	FRAME CG	CHÂSSIS CG	GESTELL CG	1	310603507	S
2	CONTROL ARM CG	BRAS DE COMMANDE CG	STEUERARM CG	1	310603508	S
3	PLANETARY CG 450 UNO	PLANÉTAIRE CG 450 UNO	PLANETEN-GETRIEBE CG 450 UNO	1	310603452	S
4	PLANETARY HOUSING CG 450 UNO	CARTER PLANÉTAIRE CG 450 UNO	PLANETEN-GETRIEBEGEHÄUSE CG 450 UNO	1	310603451	S
5	ENGINE CG	MOTEUR CG	MOTOR CG	1	310603512	S
6	PROTECTIVE SKIRT CG	JUPE DE PROTECTION CG	SCHUTZROCK CG	1	310603447	S
7	ELECTRICAL CABINET CG	COFFRET ÉLECTRIQUE CG	ELEKTRISCHES GEHÄUSE CG	1	310603502	S
8	TOOL HOLDER Ø200 CG	PORTE-OUTILS Ø200 CG	WERKZEUGHALTER Ø200 CG	3	310603504	S
9	ELECTRICAL CABINET BRACKET CG	SUPPORT COFFRET ÉLECTRIQUE CG	HALTERUNG FÜR ELEKTRISCHES GEHÄUSE CG	1	310603509	S
10	SUCTION HOSE CG	TUYAU D'ASPIRATION CG	SAUGSCHLAUCH CG	1	310603517	S

Frame / Châssis / Gestell

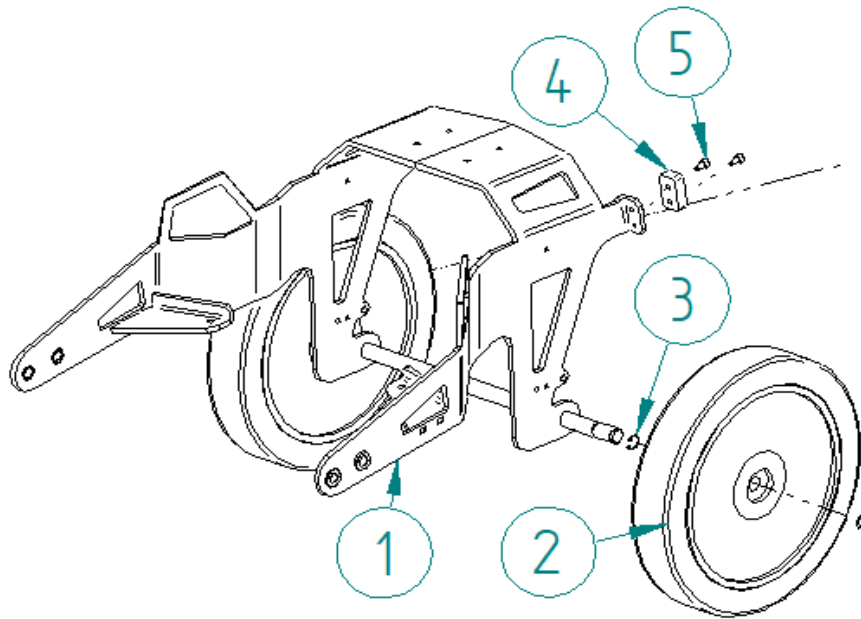

POS.	DESCRIPTION	DESCRIPTION	BESCHREIBUNG	QTY	REF	TYPE
1	FRAME CG	CADRE CG	GESTELL CG	1	310603500	S
2	WHEEL Ø300 CG	ROUE Ø300 CG	RAD Ø300 CG	2	310602790	S
3	Ø17 CIRCIP UNI 7435 CG	CIRCIP Ø17 UNI 7435 CG	Ø17 SICHERUNGSRING UNI 7435 CG	4	310602878	S
4	STOP CG	BUTÉE CG	ANSCHLAG CG	2	310603448	S
5	SCREW M6X10 UNI 5391 CG	VIS M6X10 UNI 5391 CG	SCHRAUBE M6X10 UNI 5391 CG	4	310603787	S

Control arm / Bras de commande / Steuerarm

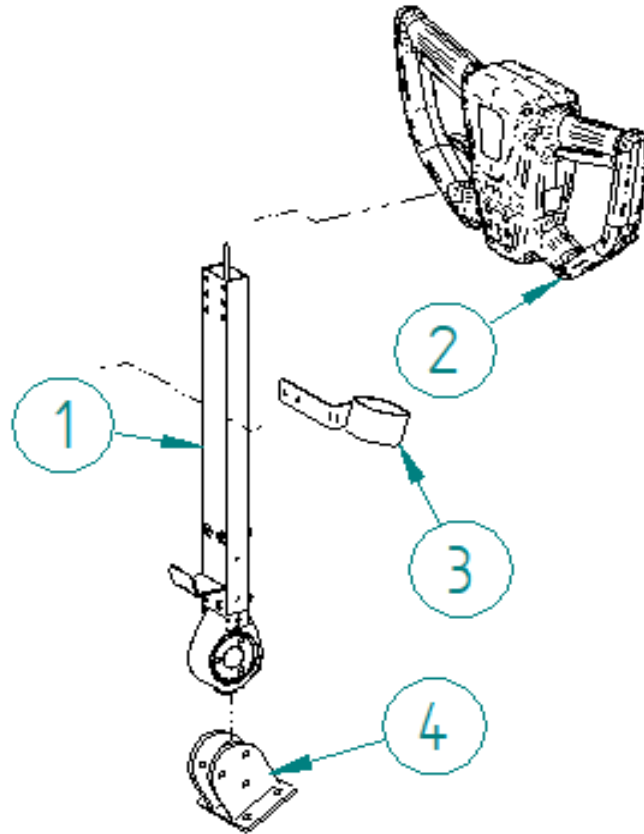

POS.	DESCRIPTION	DESCRIPTION	BESCHREIBUNG	QTY	REF	TYPE
1	SHORT HANDLE CG	MANCHE COURT CG	KURZER GRIFF CG	1	310603505	S
2	DEAD MAN'S HANDLE CG	POIGNÉE HOMME-MORT CG	TOTER-MANN-GRIFF CG	1	310602767	S
3	VACUUM HOSE SUPPORT CG	SUPPORT DE TUYAU D'ASPIRATION CG	SAUGROHR-HALTERUNG CG	1	310602757	S
4	SUPPORT FOR DEAD MAN'S ARM CG	SUPPORT BRAS HOMME-MORT CG	HALTERUNG FÜR TOTE-MANN-ARM CG	1	310603501	S

Deadman handle / Poignée homme-mort / Totmanngriff

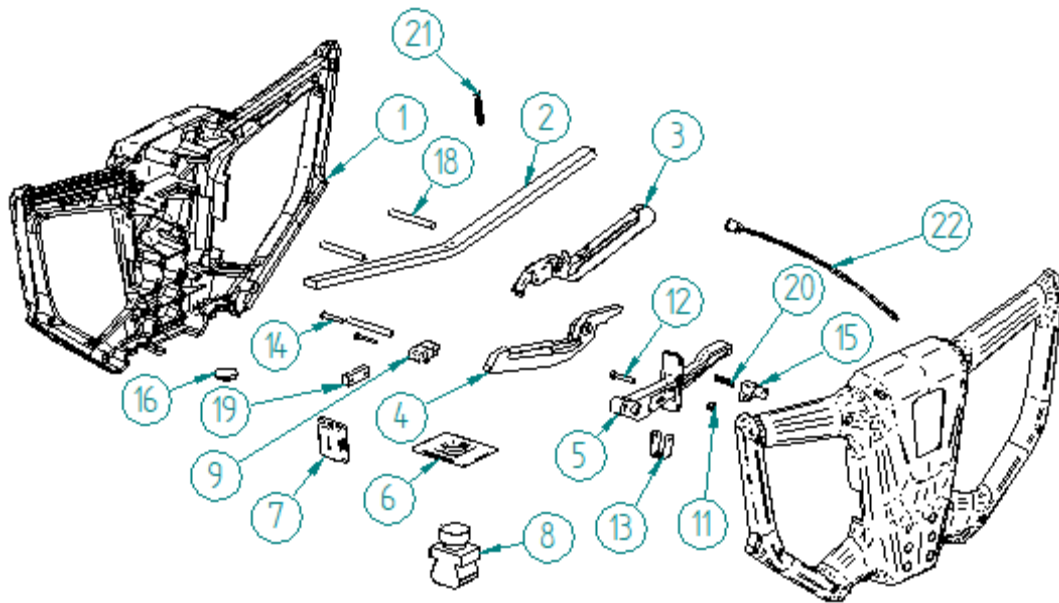

POS.	DESCRIPTION	DESCRIPTION	BESCHREIBUNG	QTY	REF	TYPE
1	DEAD MAN'S HANDLE SHELL CG	COQUE DE POIGNÉE HOMME-MORT CG	TOTMANN-GRIFFGEHÄUSE CG	2	310602731	S
2	METAL REINFORCEMENT CG	RENFORT MÉTALLIQUE CG	METALL-VERSTÄRKUNG CG	1	310602735	S
3	RIGHT START LEVER CG	LEVIER DE DÉMARRAGE DROITE CG	RECHTER STARTHEBEL CG	1	310602733	S
4	LEFT START LEVER CG	LEVIER DE DÉMARRAGE GAUCHE CG	LINKER STARTHEBEL CG	1	310602734	S
5	RELEASE LEVER CG	LEVIER DE DÉVERROUILLAGE CG	ENTRIE-GELUNGSHEBEL CG	1	310602732	S
6	SWITCH SUPPORT CG	SUPPORT INTERRUPTEUR CG	SCHALTERHALTERUNG CG	1	310602745	S
7	SIDE PLUG CG	BOUCHON LATÉRAL CG	SEITLICHER STOPFEN CG	1	310602746	S
8	SWITCH CG	INTERRUPTEUR CG	SCHALTER CG	1	310602727	S
9	CABLE BASE BLOCK CG	BLOC DE BASE DE CÂBLE CG	KABELBASISBLOCK CG	1	310602765	S
11	NUT M4 DIN 985 CG	ÉCROU M4 DIN 985 CG	MUTTER M4 DIN 985 CG	1	310602885	S
12	SCREW M4X25 UNI 5931 CG	VIS M4X25 UNI 5931	SCHRAUBE M4X25 UNI 5931	1	310602899	S
13	CABLE TIE CG	ATTACHE CÂBLE CG	KABELBINDER CG	1	310602766	S
14	SCREW 4X20 UNI 9709 CG	VIS 4X20 UNI 9709 CG	SCHRAUBE 4X20 UNI 9709 CG	2	310602898	S
15	BUTTON CG	BOUTON CG	TASTE CG	1	310602772	S
16	PLUG CG	BOUCHON CG	STOPFEN CG	1	310602773	S
18	AXIS Ø6 L=55 CG	AXE Ø6 L=55 CG	ACHSE Ø6 L=55 CG	3	310602730	S
19	CABLE BLOCK CG	BLOC CÂBLE CG	KABELBLOCK CG	1	310602771	S
20	SWITCH SPRING CG	RESSORT INTERRUPTEUR CG	SCHALTFEDER CG	1	310602774	S
21	LEVER SPRING CG	RESSORT DE LEVIER CG	HEBEL FEDER CG	2	310602775	S
22	INDICATOR LIGHT CG	VOYANT LUMINEUX CG	ANZEIGELICHT CG	1	310602788	S

Planetary / Planétaire / Planetengetriebe

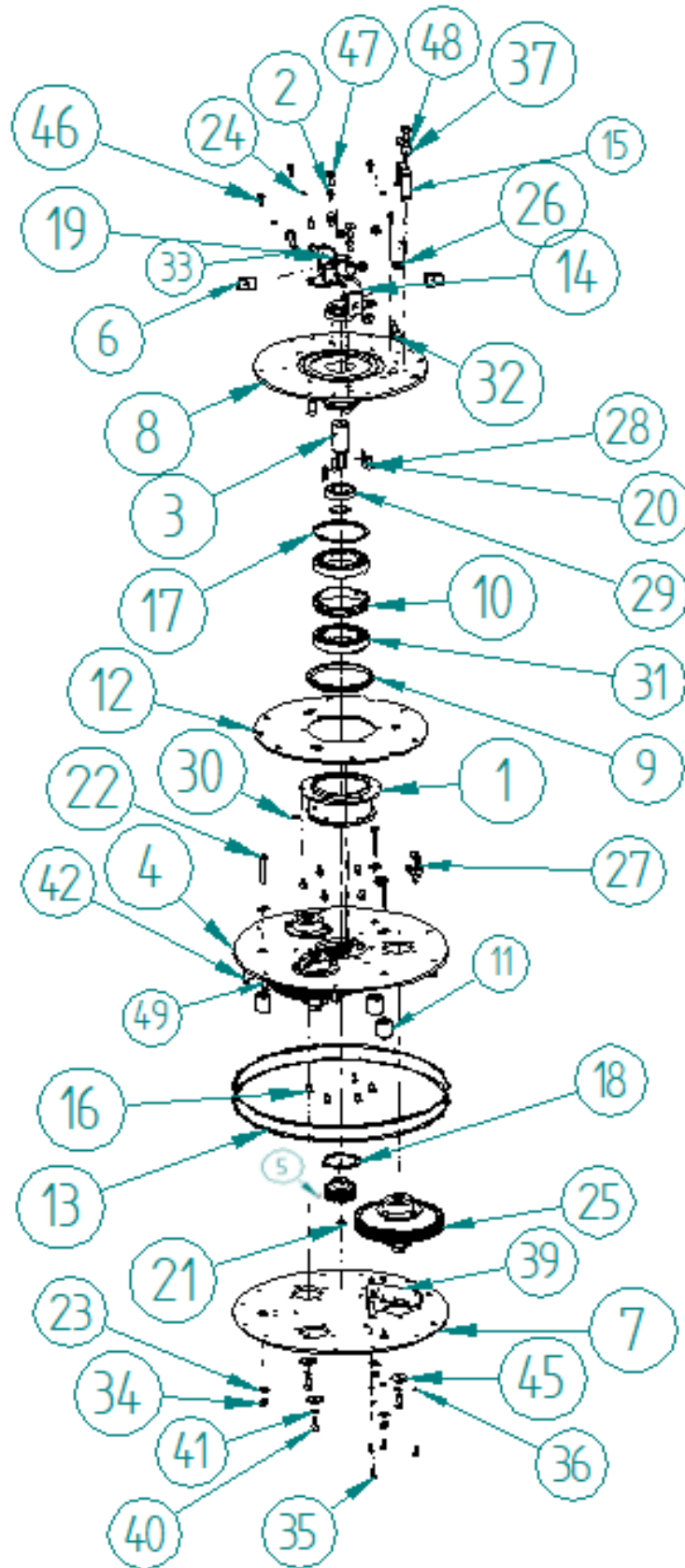

POS.	DESCRIPTION	DESCRIPTION	BESCHREIBUNG	QTY	REF	TYPE
1	DOUBLE-FLANGED SHAFT CG	ARBRE DOUBLE BRIDÉ CG	DOPPEL-GEFLANSCHTE WELLE CG	1	310603453	S
2	SCREW M8X12 UNI 5931 CG	VIS M8X12 UNI 5931 CG	SCHRAUBE M8X12 UNI 5931 CG	8	310603790	S
3	SHAFT EXTENSION CG	EXTENSION D'ARBRE CG	WELLEN-VERLÄNGERUNG CG	1	310603454	S
4	DISC FOR SHAFT CG 450 UNO	DISQUE POUR ARBRE CG 450 UNO	SCHEIBE FÜR WELLE CG 450 UNO	1	310603473	S
5	PINION CG	PIGNON CG	ZAHNRAD CG	1	310603455	S
6	THREADED PLATE CG	PLAQUE FILETÉE CG	GEWINDESTÜCK CG	2	310603499	S
7	LOWER DISC CG 450 UNO	DISQUE INFÉRIEUR CG 450 UNO	UNTERE SCHEIBE CG 450 UNO	1	310603474	S
8	MOTOR FLANGE CG	BRIDE DE MOTEUR CG	MOTORENFLANSCH CG	1	310603457	S
9	V-RING V 130 A CG	JOINT TORIQUE V 130 A CG	O-RING V 130 A CG	1	310603443	S
10	SPACER CG	ENTRETOISE CG	ABSTANDSHALTER CG	1	310603458	S
11	SPACER CG	ENTRETOISE CG	ABSTANDSHALTER CG	3	310603459	S
12	DISC FOR PLANETARY BLOCK CG	DISQUE POUR BLOC PLANÉTAIRE CG	SCHEIBE FÜR PLANETENBLOCK CG	1	310603460	S
13	SHEET METAL HOUSING CG 450 UNO	CARTER EN TÔLE CG 450 UNO	BLECHKASTEN CG 450 UNO	1	310603456	S
14	HEAD SUPPORT CG	SUPPORT DE TÊTE CG	KOPFSTÜTZE CG	2	310603497	S
15	FRONT SUPPORT CG	SUPPORT AVANT CG	VORDERE HALTERUNG CG	1	310603461	S
16	SCREW M8X16 UNI 5933 CG	VIS M8X16 UNI 5933 CG	SCHRAUBE M8X16 UNI 5933 CG	6	310603792	S
17	Ø115 CIRCIP UNI7437 CG	CIRCIP Ø115 UNI 7437 CG	Ø115 SICHERUNGSRING UNI7437 CG	1	310603735	S
18	Ø75 CIRCIP UNI 7435 CG	CIRCIP Ø75 UNI 7435 CG	Ø75 SICHERUNGSRING UNI 7435 CG	1	310603734	S
19	Ø35 CIRCIP UNI 7435 CG	CIRCIP Ø35 UNI 7435 CG	Ø35 SICHERUNGSRING UNI 7435 CG	2	310603733	S
20	KEY 6X6X32 UNI6604-A CG	CLAVETTE 6X6X32 UNI6604-A CG	KEIL 6X6X32 UNI6604-A CG	2	310603777	S
21	Ø20 CIRCIP UNI 7435 CG	CIRCIP Ø20 UNI 7435 CG	Ø20 SICHERUNGSRING UNI 7435 CG	1	310602880	S
22	SCREW M8X60 UNI 5737 CG	VIS M8X60 UNI 5737 CG	SCHRAUBE M8X60 UNI 5737 CG	3	310603792	S
23	WASHER M8 DIN 6340 CG	RONDELLE M8 DIN 6340 CG	SCHEIBE M8 DIN 6340 CG	6	310603780	S
24	WASHER M6 UNI 6592 CG	RONDELLE M6 UNI 6592 CG	SCHEIBE M6 UNI 6592 CG	5	310602893	S
25	INDEXER CG	INDEXEUR CG	INDEXIERER CG	3	310603506	S

Planetary / Planétaire / Planetengetriebe

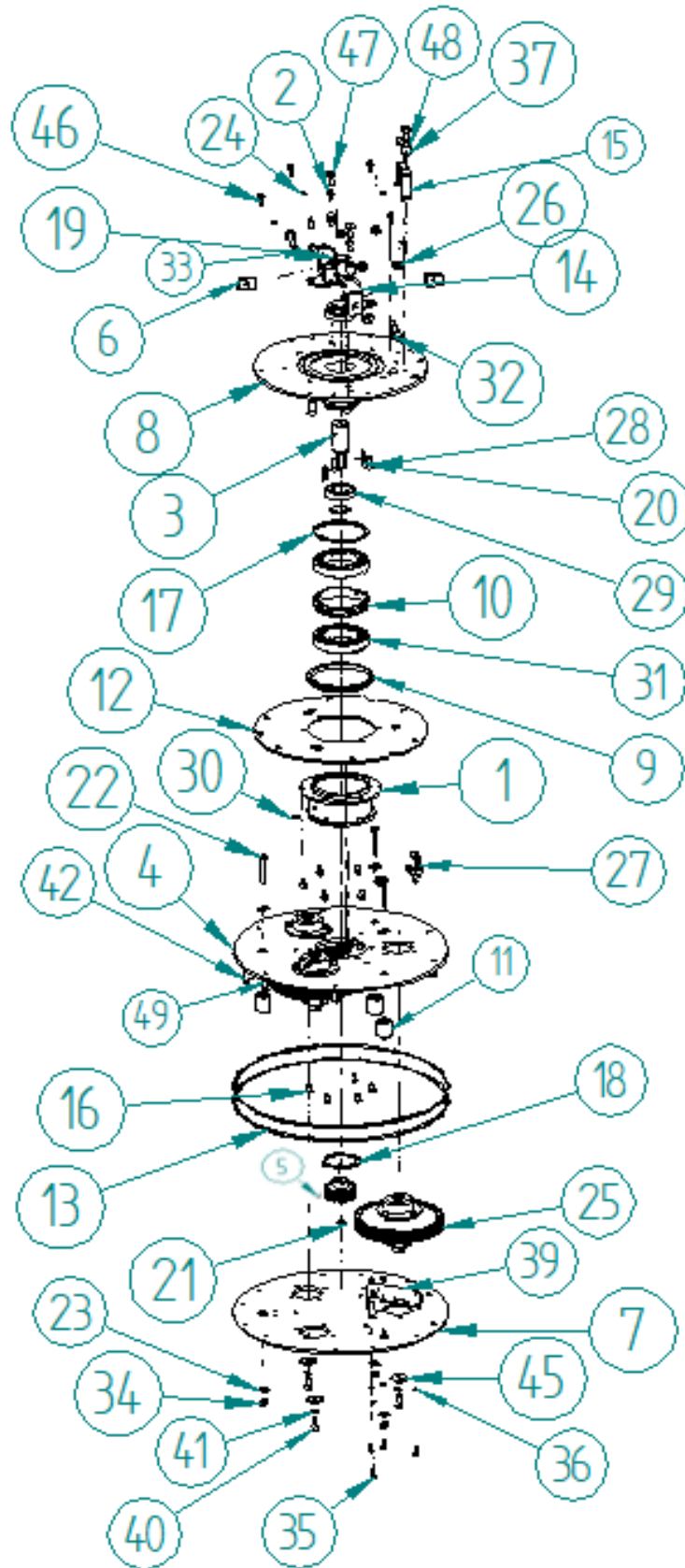

POS.	DESCRIPTION	DESCRIPTION	BESCHREIBUNG	QTY	REF	TYPE
26	SATELLITE ASSEMBLY CG	ENSEMBLE SATELLITE CG	SATELLITEN-BAUGRUPPE CG	4	310602881	S
27	SCREW M10X25 UNI 5933 CG	VIS M10X25 UNI 5933 CG	SCHRAUBE M10X25 UNI 5933 CG	1	310603444	S
28	NUT M10 DIN 985 CG	ÉCROU M10 DIN 985 CG	MUTTER M10 DIN 985 CG	4	310603782	S
29	BEARING 6007 2RS1 (35-62-14) CG	ROULEMENT 6007 2RS1 (35-62-14) CG	LAGER 6007 2RS1 (35-62-14) CG	2	310603440	S
30	GREASER TSD M6 UNI7663-A CG	GRAISSEUR TSD M6 UNI7663-A CG	SCHMIERNIPPEL TSD M6 UNI7663-A CG	1	310603510	S
31	BEARING 6015 RS1 (75-115-20) CG 450 UNO	ROULEMENT 6015 RS1 (75-115-20) CG450UNO	LAGER 6015 RS1 (75-115-20) CG 450 UNO	2	310603441	S
32	SCREW M12X65 UNI 5737 CG 450 UNO	VIS M12X65 UNI 5737 CG 450 UNO	SCHRAUBE M12X65 UNI 5737 CG 450 UNO	2	310603785	S
33	WASHER M12 UNI 6592 CG	RONDELLE M12 UNI 6592 CG	SCHEIBE M12 UNI 6592 CG	2	310603778	S
34	NUT M8 DIN 985 CG	ÉCROU M8 DIN 985 CG	MUTTER M8 DIN 985 CG	3	310602888	S
35	SCREW M5X15 UNI 5931 CG	VIS M5X15 UNI 5931 CG	SCHRAUBE M5X15 UNI 5931 CG	12	310603786	S
36	WASHER M5 UNI 1751 CG	RONDELLE M5 UNI 1751 CG	SCHEIBE M5 UNI 1751 CG	12	310603779	S
37	SCREW M6X10 UNI 5391 CG	VIS M6X10 UNI 5391 CG	SCHRAUBE M6X10 UNI 5391 CG	2	310603787	S
39	PLANETARY JOINT CG 450 UNO	JOINT PLANÉTAIRES CG 450 UNO	PLANETEN-GETRIEBEGELENK CG 450 UNO	3	310603462	S
40	SCREW M8X20 UNI 5931 CG	VIS M8X20 UNI 5931 CG	SCHRAUBE M8X20 UNI 5931 CG	3	310603791	S
41	WASHER M8 UNI 1751 B CG	RONDELLE M8 UNI 1751 B CG	SCHEIBE M8 UNI 1751 B CG	3	310603781	S
42	NUT M5 DIN982 CG	ÉCROU M5 DIN982 CG	MUTTER M5 DIN982 CG	12	310603776	S
45	SPACER 32X8.2X5 CG	ENTRETOISE 32X8,2X5 CG	ABSTANDSHALTER 32X8,2X5 CG	3	310603463	S
46	SCREW M6X18 UNI 5931 CG	VIS M6X18 UNI 5931 CG	SCHRAUBE M6X18 UNI 5931 CG	5	310603789	S
47	SCREW M10X35 UNI 5931 CG 450 UNO	VIS M10X35 UNI 5931 CG 450 UNO	SCHRAUBE M10X35 UNI 5931 CG 450 UNO	3	310603783	S
48	SPACER CG	ENTRETOISE CG	ABSTANDSHALTER CG	3	310603503	S
49	NUT M8X35 UNI 5535 CG	ÉCROU M8X35 UNI 5535 CG	MUTTER M8X35 UNI 5535 CG	11	310603731	S

Satellite assembly / Ensemble satellite / Satellitenbaugruppe

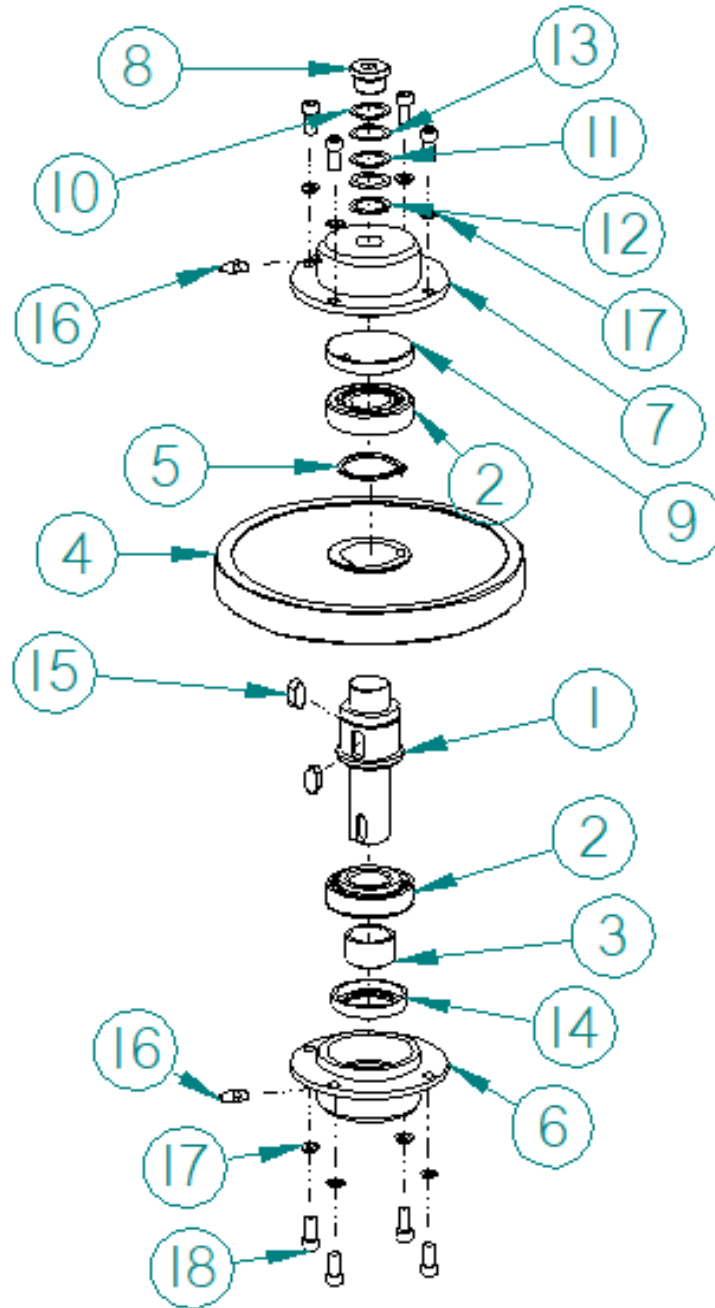

POS.	DESCRIPTION	DESCRIPTION	BESCHREIBUNG	QTY	REF	TYPE
1	SATELLITE SHAFT CG	ARBRE SATELLITE CG	SATELLITENWELLE CG	1	310603469	S
2	BEARING 30205 CG	ROULEMENT 30205 CG	LAGER 30205 CG	2	310603438	S
3	SKF IR 25X30X17 CG	SKF IR 25X30X17 CG	SKF IR 25X30X17 CG	1	310603511	S
4	SATELLITE M=2 Z=90 CG	SATELLITE M=2 Z=90 CG	SATELLIT M=2 Z=90 CG	1	310603468	S
5	Ø35 CIRCIP UNI 7435 CG	CIRCIP Ø35 UNI 7435 CG	Ø35 SICHERUNGSRING UNI 7435 CG	1	310603733	S
6	CUP CG	COUPE CG	BECHER CG	1	310603470	S
7	CUP WITH ADJUSTMENT CG	COUPE AVEC RÉGLAGE CG	BECHER MIT EINSTELLUNG CG	1	310603471	S
8	STEEL PLUG DIN 908 M18X1.5 CG	BOUCHON EN ACIER DIN 908 M18X1,5 CG	STAHLSTOPFEN DIN 908 M18X1,5 CG	1	310603442	S
9	MOBILE SLIDER CG	CURSEUR MOBILE CG	GLEITSCHLITTEN CG	1	310603472	S
10	WASHER 18X25X0.2 CG	RONDELLE 18X25X0,2 CG	SCHEIBE 18X25X0,2 CG	1	310603513	S
11	WASHER 18X25X0.5 CG	RONDELLE 18X25X0,5 CG	SCHEIBE 18X25X0,5 CG	1	310603515	S
12	WASHER 18X25X1 CG	RONDELLE 18X25X1 CG	SCHEIBE 18X25X1 CG	2	310603516	S
13	WASHER 18X25X0.3 CG	RONDELLE 18X25X0,3 CG	SCHEIBE 18X25X0,3 CG	1	310603514	S
14	OIL SEAL WITH LIP 30X45X8 CG	JOINT D'HUILE AVEC LÈVRE 30X45X8 CG	ÖLDICHTUNG MIT LIPPE 30X45X8 CG	1	310603439	S
15	KEY 8X7X18 UNI6604 - A CG	CLAVETTE 8X7X18 UNI6604 - A CG	KEIL 8X7X18 UNI6604 - A CG	2	310602889	S
16	GREASER TSD M6 UNI7663-A CG	GRAISSEUR TSD M6 UNI7663-A CG	FETTPRESSE TSD M6 UNI7663-A CG	2	310603518	S
17	WASHER M6 UNI 6592 CG	RONDELLE M6 UNI 6592 CG	SCHEIBE M6 UNI 6592 CG	8	310602893	S
18	SCREW M6X14 UNI 5931 CG	VIS M6X14 UNI 5931 CG	SCHRAUBE M6X14 UNI 5931 CG	8	310603788	S

Planetary housing / Carter planétaire / Planetengetriebegehäuse

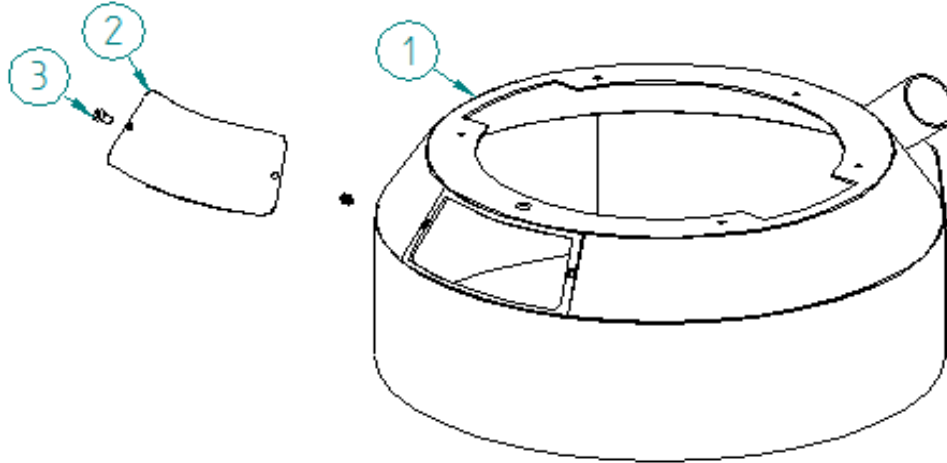

POS.	DESCRIPTION	DESCRIPTION	BESCHREIBUNG	QTY	REF	TYPE
1	PLANETARY HOUSING CG 450 UNO	CARTER PLANÉTAIRE CG 450 UNO	PLANETENGEHÄUSE CG 450 UNO	1	310603445	S
2	HOUSING COVER CG 450 UNO	COUVERCLE CARTER CG 450 UNO	GEHÄUSEDECKEL CG 450 UNO	1	310603446	S
3	SCREW M6X10 UNI 5391 CG	VIS M6X10 UNI 5391 CG	SCHRAUBE M6X10 UNI 5391 CG	2	310603787	S

Tool holder Ø200 / Porte-outils Ø200 / Werkzeughalter Ø200

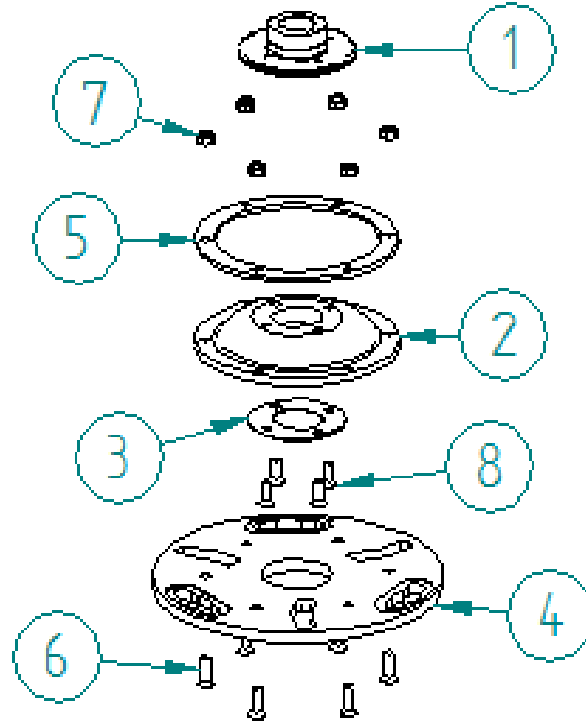

POS.	DESCRIPTION	DESCRIPTION	BESCHREIBUNG	QTY	REF	TYPE
1	TOOL HOLDER FLANGE CG	BRIDE D'OUTIL CG	WERKZEUGFLANSCH CG	1	310603464	S
2	FLEXIBLE JOINT 140 CG	JOINT FLEXIBLE 140 CG	FLEXIBLES GELENK 140 CG	1	310603465	S
3	COUPLING PLATE CG	PLAQUE D'ACCOUPEMENT CG	KUPPLUNGSPLATTE CG	1	310603466	S
4	TOOL HOLDER Ø200 WITH MAGNET CG	PORTE OUTIL Ø200 AVEC AIMANT CG	WERKZEUGHALTER Ø200 MIT MAGNET CG	1	310603449	S
5	UPPER RING CG	BAGUE SUPÉRIEURE CG	OBERER RING CG	1	310603467	S
6	SCREW M6X20 UNI 5933 CG	VIS M6X20 UNI 5933 CG	SCHRAUBE M6X20 UNI 5933 CG	6	310603732	S
7	NUT M6 DIN 985 CG	ÉCROU M6 DIN 985 CG	MUTTER M6 DIN 985 CG	6	310603729	S
8	SCREW M6X16 UNI 5931 INOX CG	VIS M6X16 UNI 5931 INOX CG	SCHRAUBE M6X16 UNI 5931 INOX CG	4	310602901	S

Tool holder Ø200 QA/Ready with magnet / Porte outil
 Ø200 QA/Ready avec aimant / Werkzeughalter Ø200
 QA/Ready mit magnet

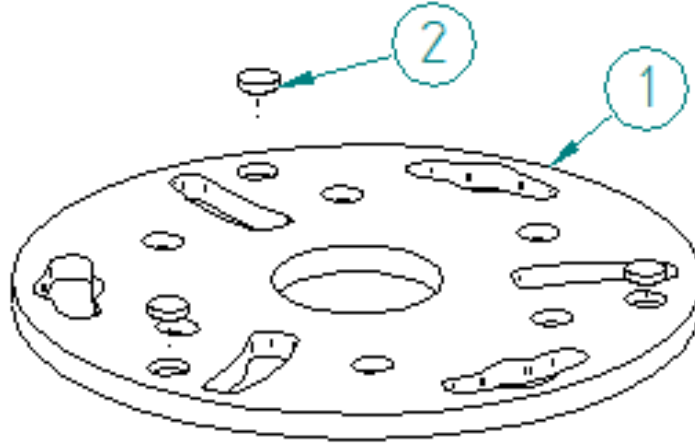

POS.	DESCRIPTION	DESCRIPTION	BESCHREIBUNG	QTY	REF	TYPE
1	TOOL HOLDER Ø200 CG	PORTE OUTIL Ø200 CG	WERKZEUGHALTER Ø200 CG	1	310603450	S
2	MAGNET Ø 12 CG	AIMANT Ø12 CG	MAGNET Ø12 CG	3	310602787	S

SAINT-GOBAIN ABRASIVES
INDUSTRIEWEG 21
9420 ERPE-MERE
BELGIUM
TEL: +32(0) 2 267 21 00

SAINT-GOBAIN ABRASIVES, S.R.O.
POČERNICKÁ 272/96, MALEŠICE
108 00 PRAHA 10
CZECH REPUBLIC
TEL: +420 255 719 326
FAX: +420 255 719 321

SAINT-GOBAIN ABRASIVES A/S
DYBENDALSVEJENGET 2,
DK-2630 TAASTRUP
DENMARK
TEL: +45 4675 5244

PO BOX 643706
FORTUNE TOWER OFFICE 2106
JLT BLOCK C
(NEXT TO METRO STATION)
JUMEIRA LAKE TOWER, DUBAI
UNITED ARAB EMIRATES
TEL: +971 4 431 5154
FAX: +971 4 431 5434

SAINT-GOBAIN ABRASIFS
RUE DE L'AMBASSADEUR - B.P.8
78 702 CONFLANS CEDEX
FRANCE
TEL: +33 (0)1 34 90 40 00
FAX: +33 (0)1 39 19 89 56

SAINT-GOBAIN ABRASIVES GMBH
BIRKENSTRASSE 45-49
D-50389 WESSELING
GERMANY
TEL: +49 (0) 2236 703-0
FAX: +49 (0) 2236 703-730

SAINT-GOBAIN ABRASIVES KFT.
1225 BUDAPEST
BÁNYALÉG U. 60/B.
HUNGARY
TEL: +36 1 371 22 50
FAX: +36 1 371 22 55

SAINT-GOBAIN ABRASIVI S.P.A
VIA PER CESANO BOSCONI 4
I-20094 CORSICO MILANO
ITALY
TEL: +39 02 44 851
FAX: +39 02 44 78 266

SAINT-GOBAIN ABRASIVES S.A.
190 RUE J.F. KENNEDY
L-4930 BASCHARAGE
GRAND DUCHE DE LUXEMBOURG
TEL: +352 50 401 1
FAX: +331 83 717 792
NO. VERT (FRANCE): 0800 906 903

SAINT-GOBAIN ABRASIFS, S.A.
2 ALLÉE DES FIGUIERS
AIN SEBAË - CASABLANCA
MOROCCO
TEL: +212 5 22 66 57 31
FAX: +212 5 22 35 09 65

SAINT-GOBAIN ABRASIVES BV
GROENLOSEWEG 28
7151 HW EIBERGEN
P.O. BOX 10
7150 AA EIBERGEN
THE NETHERLANDS
TEL: +31 545 466466
FAX: +31 545 474605

SAINT-GOBAIN ABRASIVES AS
KARIHAUGVEIEN, 89
0186 OSLO
NORWAY
TEL: +47 63 87 06 00
FAX: +47 63 87 06 01

SAINT-GOBAIN HPM POLSKA SP. Z O.O.
UL. NORTON 1, 62-600 KOŁO
62-600 KOŁO
POLAND
TEL: +48 63 26 17 100
FAX: +48 63 27 20 401

SAINT-GOBAIN ABRASIVOS, L. DA
ZONA INDUSTRIAL DA MAIA
I-SECTOR VIII, NO. 122
APARTADO 6050
4476 - 908 MAIA
PORTUGAL
TEL: +351 229 437 940
FAX: +351 229 437 949

SAINT-GOBAIN GLASS
BUSINESS UNIT ABRASIVI
PUNCT DE LUCRU : LOC.VETIS, JUD.
SATU MARE 447355
STR. CAREIULUI 11
PARC INDUSTRIAL RENOVATIO
ROMANIA
TEL: +40 261 839 709
FAX: +40 261 839 710

SG HPM RUS
58, F. ENGELS STR.
STROENIE 2
105082 MOSCOW
RUSSIA
TEL: +74 955 408 355
FAX: +74 959 373 224

SAINT-GOBAIN
ABRASIVES (PTY) LTD
2 MONTEER ROAD
ISANDO 1600
P.O. BOX 67
SOUTH AFRICA
TEL: +27 11 961 2000
FAX: +27 11 961 2184/5

SAINT-GOBAIN ABRASIVOS, S.A.
CTRA. DE GUIPÚZCOA, KM. 7,5
E-31195 BERRIOPLANO (NAVARRA)
SPAIN
TEL: +34 948 306 000
FAX: +34 948 306 042

SAINT GOBAIN ABRASIVES AB
GÅRDSFOGDEVÄGEN 18A
168 66 BROMMA • SVERIGE
SWEDEN
TEL: +46 8 580 881 00
FAX: +46 8 580 881 30

SAINT-GOBAIN INOVATIF MALZEMELER
VE ASINDIRICI SAN. TIC. AS.
ALTAYÇEŞME MAH. ÇAMLI SOK. NO:21
ESAS OFIS PARK KAT:9 34843
MALTEPE, İSTANBUL • TURKEY
TEL: 0090-216-217 12 50
FAX: 0090-216-442 40 74

SAINT-GOBAIN ABRASIVES LTD.
UNICORN HOUSE UNIT 1, AMISON CLOSE
REDHILL BUSINESS PARK
STAFFORD ST161WB
UNITED KINGDOM
TEL: +44 1785 279 553
FAX: +44 1785 213 487



Saint-Gobain Abrasifs
190 Rue J.F. Kennedy
L-4930 Bascharage
Grand Duché de Luxembourg
Tel: +331 83717792
Fax: +352 50 16 33
no. vert (France) 0800 906 903

www.nortonabrasives.com/fr-fr