

CWT 450

OPERATING INSTRUCTIONS

Translation of the original instructions



SAINT-GOBAIN





Declaration of Conformity

The undersigned manufacturer:

SAINT - GOBAIN ABRASIVES SA
190, BD. JF KENNEDY
L-4930 BASCHARAGE

Declares that the products: **CWT 450** Code: **70184631920**

is in conformity with the following standard:

- **"MACHINES" 2006/42 / EC**
- **"LOW VOLTAGE" 2014/35 / UE**
- **"électromagnétique Compatibility" 2014/30 / EC**
- **"NOISE" 2000/14 / EC**

And the European standards:

- **UNI EN ISO 12100: 2010** Machinery safety, General design principles. Risk assessment and risk reduction
- **CEI EN 60204-1: 2018** Safety of machinery (electrical equipment of machines) (machines with electrical control)
- **UNI EN 19085-10: 2020** Safety of woodworking machines Circular saws, Construction site bench saw.

Valid for machines as of serial number: **4503110140001**

Storage site for the technical documents:

Saint-Gobain Abrasives 190, Bd. JF Kennedy 4930 BASCHARAGE, LUXEMBOURG

This declaration of conformity loses its validity when the product is converted or modified without agreement.

Bascharage , Luxembourg 25/02/2022

Fabrice Genuardi , Quality manager



Declaration of Conformity

The undersigned manufacturer:

SAINT - GOBAIN ABRASIVES SA
190, BD. JF KENNEDY
L-4930 BASCHARAGE

Declares that the products: **CWT 450** Code: **70184631920**
is in conformity with the following standard:

- ***Supply of Machinery (Safety) Regulations 2008***
- ***Electrical Equipment (Safety) Regulations 2016***
- ***Electromagnetic Compatibility Regulations 2016***
- ***Noise Emission in the Environment by Equipment for use Outdoors Regulations 2001***

And the European Standards:

- **UNI EN ISO 12100: 2010** Machinery safety, General design principles. Risk assessment and risk reduction
- **CEI EN 60204-1: 2018** Safety of machinery (electrical equipment of machines) (machines with electrical control)
- **UNI EN 19085-10: 2020** Safety of woodworking machines Circular saws, Construction site bench saw.

Valid for machines as of serial number: **4503110140001**

Authorised Representative:

SAINT-GOBAIN ABRASIVES

Unicorn House • Unit 1, Amison Close

Redhill Business Park • Stafford • England • ST16 1WB

This declaration of conformity loses its validity when the product is converted or modified without agreement.

Bascharage , Luxembourg 17/02/2022

Fabrice Genuardi , Quality manager

**PRODUCT DESCRIPTION:**

Circular saw for cutting wooden planks and joists and similar.



ATTENTION: upon arrival, the machine must be immediately checked. If any transport damage or missing parts are found, immediately send a written damage report to the shipper. Therefore also inform the supplier.



ATTENTION: for the safety of the buyer and of any employee or user, it is advisable, before starting the machine, to carefully read the instructions contained in this user manual.



ATTENTION: only people capable of doing their own work reliably will be able to work on and with the machine. The operator must ensure that unauthorized persons are kept duly away from the machine.

CWT 450 SUMMARY

PRODUCT DESCRIPTION:.....	5
1 - GENERAL INFORMATION	7
1.1 PURPOSE OF THE MANUAL	7
1.2 USERS OF THE MANUAL	7
1.3 PRESERVATION OF THE MANUAL	8
1.4 LIABILITY AND WARRANTY	8
1.5 MANUFACTURER'S DISCLAIMER	8
2 - TECHNICAL INFORMATION	9
2.1 IDENTIFICATION	9
2.2 DESCRIPTION OF THE "Fixed blade" MACHINE	9
2.3 DIMENSIONS AND FEATURES "Fixed blade model"	11
3- GENERAL SAFETY RULES	12
3.1 PREMISE	12
3.2 POSITIONING THE MACHINE (fig. 1)	13
3.3 SAFETY PRECAUTIONS	14
3.4 Symbol used in the manual.....	15
4 - HANDLING AND INSTALLATION	17
4.1 TRANSPORTATION BY TRUCK	17
4.2 LOADING UNLOADING AND HANDLING	17
4.3 PRELIMINARY CHECKS	18
5 - STARTING AND STOPPING.....	19
5.1 STARTING AND STOPPING THE MACHINE.....	19
5.2 INSTRUCTIONS FOR USING THE ELECTRICAL EQUIPMENT	20
5.3 ANOMALIES AND REMEDIES	21
5.4 BLADE COVER CAP	22
6 - USE OF THE MACHINE	23
6.1 USE OF THE CIRCULAR SAW.....	23
6.2 CUTTING DISC.....	23
6.3 USE OF THE SQUARE GUIDE.....	25
6.4 LONGITUDINAL AND SIDE PUSHER	26
6.5 EXTENSION OF THE WORK BENCH	27
6.6 STABILITY' OF THE MACHINE (Fig 19)	28
6.7 CHIP DISCHARGE SLOT AND SUCTION MOUTH.....	28
7 - MAINTENANCE.....	29
7.1 REPLACEMENT OF THE BELT	29
7.2 REPLACEMENT OF THE BLADE	30
7.3 BRAKING TIME.....	31
7.4 DESCRIPTION OF THE PERIODIC CHECKS TO BE CARRIED OUT ON THE MACHINE BEFORE USE	32
7.5 DISMANTLING	32
8- TRI-PHASE WIRING DIAGRAM	33
Customer service	34
Spare parts	35

1 - GENERAL INFORMATION

1.1 PURPOSE OF THE MANUAL

The purpose of this manual is to provide the information necessary for assembly, use, maintenance and safety regarding the machine in question. The instructions contained therein are aimed at obtaining maximum performance in terms of performance, productivity, technological result, safeguarding the safety of the personnel in charge and the integrity of the machine.

Therefore, all operations, from assembly to maintenance, must be carried out as indicated to avoid accidents to personnel and damage to the machine.



THE SERVICE INSTRUCTIONS CONTAINED IN THE MANUAL, ABSOLVE TO THEIR DUTY TO THE EXTENT IN WHICH THEY ARE IN THE IMMEDIATE VICINITY OF THE USERS OF THE MACHINE, OF THE ASSEMBLY PERSONNEL AND OF THE MAINTENANCE MANAGERS. THEREFORE, MAKE SURE THAT THE MANUAL ALWAYS STAYS CLOSE TO THE MACHINE.

1.2 USERS OF THE MANUAL

The manual is mainly intended for users of the machine, assembly workers and maintenance managers. The plant manager must in any case be aware of all the instructions containing the safety recommendations (behavior of the employees, limits of use of the machine, environmental conditions, maintenance planning, etc.) and must ensure that these are respected to avoid danger to personnel and damage to the machine. The Saint-Gobain company can modify the machine to improve the product, without any notice, therefore there may be differences between the machine in your possession and the illustrations in this manual, however safety and information

1.3 PRESERVATION OF THE MANUAL

The manual must be carefully kept in a place suitable for correct storage to ensure its physical integrity; it must be easily accessible to anyone authorized to consult it.

The manual is an important document that accompanies the machine and all users must be responsible for its protection. Any replacement copies can be requested directly from **Saint-Gobain**, quoting the serial number of the machine and the year of construction.

1.4 LIABILITY AND WARRANTY

The **Saint-Gobain** company guarantees that the machine is designed and built according to the prescriptions imposed by the current Community Directives 2006/42 / EC. of the new owner to facilitate the transmission of any additions to the manual.

1.5 MANUFACTURER'S DISCLAIMER

The **Saint-Gobain** company declines all responsibility if the safety level of any machine is compromised by tampering, by any type of intervention not provided for in this manual, or by failure to comply with the advice and warnings given here. **Saint-Gobain** is not responsible for damage or accidents due to inexperience in the replacement of parts or components concerning safety devices, carried out by the user or by his representatives.





2 - TECHNICAL INFORMATION

2.1 IDENTIFICATION

SAINT-GOBAIN
 190, Bd. John F. Kennedy L-4930 BASCHARAGE

UKCA CE
 2006/42/CE

Type
 Mod.
 Serial Nb Date
 V A Kw Hz Kg

The following data are shown on the machine plate:

- Manufacturer identification
- Machine model and serial number
- Voltagepower supply (Volt)
- Electric motor amps (A)
- Electric motor power (Kw)
- Power supply frequency (Hertz)
- Machine weight (Kg)
- Year of construction

2.2 DESCRIPTION OF THE "Fixed blade" MACHINE

It uses a work bench in which the material is manually brought into contact with a circular blade applied under the bench itself.

The machine is synthetically built by:

- base frame, in electro-welded sheet metal, constituting a frame for fixing the drive members and the relative worker member as well as workbench;
- actuation members consisting of a motor unit, kinematic belt transmission and blade holder shaft;
- **worker member consisting of circular saw in fixed position with diameter 450 mm, hole Ø30, sp 4.4/3 , Z36, fixed with threaded friction disc to the shaft;**
- safety systems for the purposes of the risks associated with processing.

The machine identifies itself as:

Mod. CWT450 Tri-phase power supply 400V 50 Hz (fixed blade)

- 1 - Table 70x108 cm
- 2 - Self-adjusting headset
- 3 - Extendable table cm.48x74
- 4 - Dividing wedge
- 5 - Control switch
- 6 - Longitudinal square
- 7 - Cross square
- 8 - Lifting eyes
- 9 - Blade group
- 10 - Service key
- 11 - Pusher
- 12 - Side pusher
- 13 - user manual

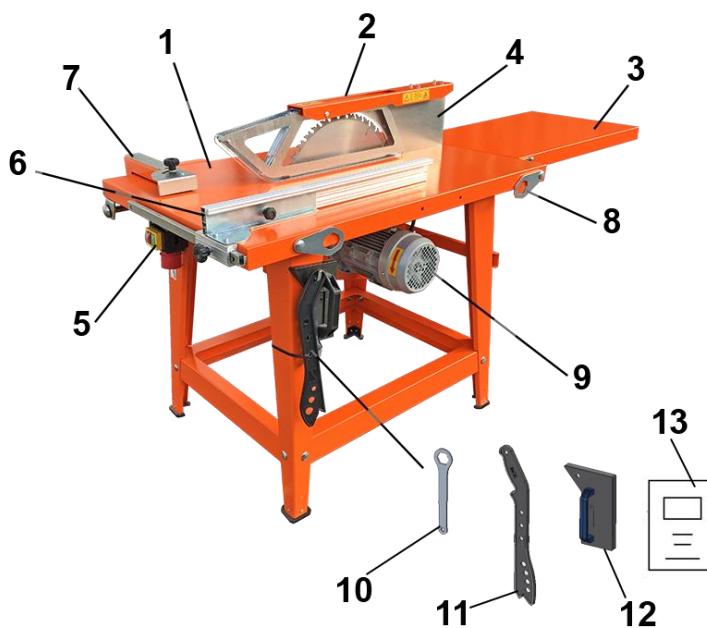

2.3 DIMENSIONS AND FEATURES "Fixed blade model"

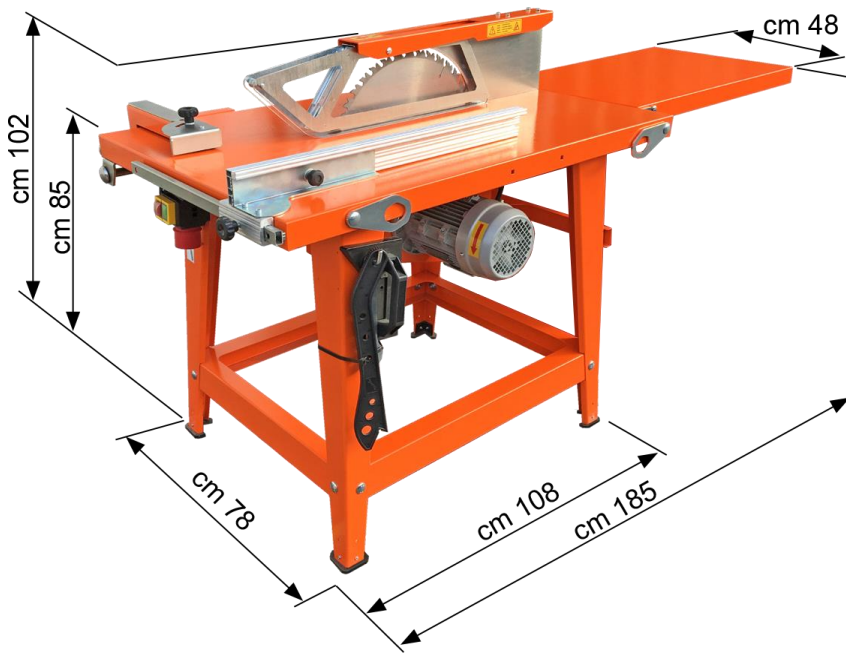

model	Power	Nortn Clipper tooth bade	RPM	Useful cut	Weight Kg
CWT450	3 Kw - 400V tri phase	Ø450 Ø30 sp 4.4/3 , Z36	2860 g/min	155 mm	102

Sound levels with the use of a special blade with 28 teeth and Ø 315mm		
Equivalent continuous sound pressure level in the workplace	dB (A)	93.7
Sound power level emitted by the machine	dB (A)	104.7
ISO 7960: 1995 / ISO 19085-10		

“The quoted values for noise are emission levels and not necessarily safe working levels. While there is a correlation between emission levels and exposure levels, this cannot be reliably used to determine whether or not additional precautions are required. Factors affecting the actual exposure level of the worker include the duration of exposure, the characteristics of the environment, other emission sources, e.g. the number of machines and other adjacent processes. Permitted exposure levels may also vary from country to country. However, this information enable the user of the machine to make a better assessment of the dangers and risks ”.

Dust emission level when cutting new fir boards mg / Nm³ 34.7

MATERIALS AND PRODUCTS USED

The structure and the supporting base are made of steel sheet, painted with synthetic RAL enamel, the materials used are not harmful to the operator or to the environment.

3- GENERAL SAFETY RULES

3.1 PREMISE

Although the rigid and massive assembly offers the maximum guarantee for solidity and robustness, a good placement is always advisable to increase the solidity and eliminate unnecessary and harmful vibrations. **The manufacturer is exempt from any responsibility for any damage caused by negligence.**

SAFETY RULES

- 1) Before connecting to the electrical network, it is necessary to check that there is adequate protection upstream of the line, with differential magneto thermic protection and equipped with an earth conductor.
- 2) Check that the voltage and frequency indicated on the plate correspond to those of the net.
- 3) Do not use cables, extensions, or plugs that are defective or not compliant with the regulations.
- 4) Make sure that work is always carried out in safe conditions.
- 5) Always start work with the machine in a stable position.
- 7) Do not use or expose the tool to rain.
- 8) Position the cable correctly when working, that it always remains away from the work area and that it is long enough to allow you to work.
- 9) Remove always current from the net connection during maintenance.
- 10) Use of the machine is allowed to adults and competent people.
- 11) During work, scrupulously follow the instructions on the machine.
- 12) The machines from our production are built with the required technical and safety measures. Customers are therefore advised to strictly follow the rules described in this booklet.
- 13) To maintain the original characteristics and the validity of the certification, use original **Saint-Gobain** spare parts



ATTENTION!

Only the operator will be liable for all damages deriving from improper use of the machine.

ATTENTION!

The machine can be dangerous if used improperly. it can cause serious or fatal injuries.

It is absolutely essential that all work operations are carried out by a single operator and not by several people.

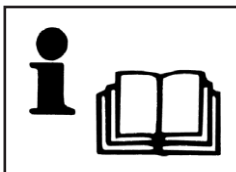

DO NOT USE THE MACHINE BEFORE READING THE MANUAL FOR INSTRUCTIONS AND UNDERSTAND THE CONTENTS.

WHAT DESCRIBED IN THIS MANUAL CONCERNS YOUR SAFETY.

- The use of the machine is recommended for adults and competent people (for those who have never used the machine, an insertion course is recommended).
- Work operations are safe if the following standards are observed.
- This booklet must be delivered to the operator and kept.
- The owner of the machine is responsible. Also make the operator responsible.
- Maintenance must be carried out with the power off, and by specialized personnel.
- It is forbidden to remove or tamper with the protections!
- Always use: protective helmet, ear muffs, protective goggles or visor, heavy or safety footwear and work gloves, do not work with loose clothing.

3.2 POSITIONING THE MACHINE (fig. 1)

A space of at least 1.5 meters must be left around the machine for the passage of people and things, without creating the risk of collisions and allowing normal maintenance operations.

A DANGEROUS AREA is to be considered any area inside and / or near a machine in which the presence of an exposed person constitutes a risk for the safety and health of that person.

Any person who is wholly or partially in a dangerous area is to be considered an EXPOSED PERSON.

The OPERATOR is the person or persons in charge of installing, operating, adjusting, maintaining, cleaning, repairing and transporting a machine.

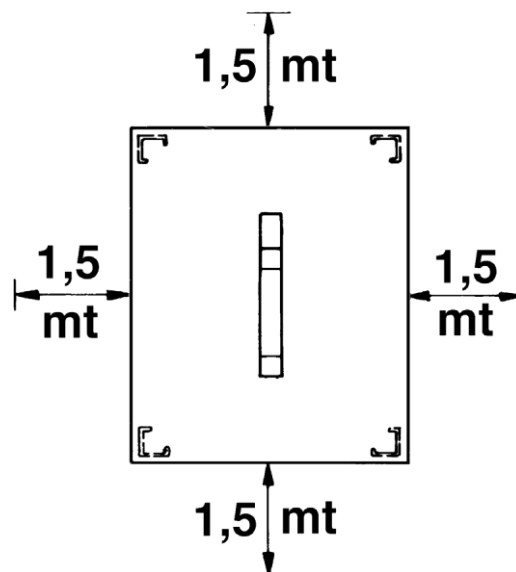

Fig.1

3.3 SAFETY PRECAUTIONS

- All the adjustment and maintenance operations must be carried out with the power socket disconnected.
- Always unplug the machine when you are not using it.
- Don't try to use the machine with any voltage other than that indicated.
- Never open the switch box as it is electronic. If necessary, consult your trusted electrician.



ATTENTION: POWER AND SOUND PRESSURE LEVELS ARE NOT NECESSARILY AT SAFETY LEVELS FOR WORK



ATTENTION!

When using power tools, always follow safety precautions, including instructions, to reduce the risk of fire, electric shock, and personal injury.

Read these instructions carefully Before using the machine and always keep this manual.



NEVER LEAVE THE MACHINE UNATTENDED.

To avoid other incompetent people who unexpectedly use the machine,



ATTENTION!

Don't use the machine if there is an abnormal noise



ATTENTION!

The machine during operation can create sources of ignition. Always keep clean the work place.

3.4 Symbol used in the manual

The plates and wordings applied to the machine must not be removed and must be kept in good condition without compromising their legibility. In case of damage they must be replaced.

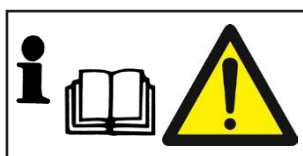

DANGER! Information

Before using the machine, it is mandatory to read the entire user manual and understand the contents! All moving parts cause danger for the operator.



GENERIC DANGER!

The machine is marked with this pictogram for all parts dangerous for the operator.



ATTENTION!

The use of the machine must not be authorized to persons who are under the influence of alcohol, drugs, medicines or lack of clarity essential for safety.



MANDATORY!

It is mandatory to wear ear muffs when using the machine.



MANDATORY!

It is mandatory to wear safety shoes when using the machine to protect yourself from any pieces of wood that may accidentally fall on your feet.



MANDATORY!

It is mandatory to wear work gloves during work to protect yourself from any splinters of wood.



MANDATORY!

It is mandatory during work to wear work glasses or a protective visor to protect against splinters.



MANDATORY!

It is mandatory during work to wear work dust protection mask



FORBIDDEN!

It is forbidden to carry out maintenance or adjustments when the machine is running.



FORBIDDEN!

It is forbidden for the user to smoke while working.



ATTENTION! ELECTRIC CURRENT

Check the correct voltage as indicated on the 400V motor nameplate.

Volt 400



FOR MACHINES WITH ELECTRIC MOTOR

Make sure that the direction of rotation of the motor is like indicated by the arrow.



DANGER!

Watch out for your hands, rotating blade



DANGER!

Mechanical parts in motion



DANGER!

Mechanical parts in motion

4 - HANDLING AND INSTALLATION

4.1 TRANSPORTATION BY TRUCK

Due to its particularly sturdy monolithic structure, the machine can be easily transported without any disassembly operations; however, it is important to pay attention to the following rules:

- make sure that the lifting ropes are correctly hooked to the four lifting eyes;
- We recommend avoiding shocks or sudden shocks both in the lifting phase and in the support phase of the structure;
- in the case of long journeys with routes that are not necessarily straight, it is very important to tie the structure well to the means of transport, because the center of gravity is very high and accidents can occur due to speed both when cornering and on bumps or slopes;
- all machines are equipped with special lifting hooks, so please use them in order to avoid inconveniences.

4.2 LOADING UNLOADING AND HANDLING

The machine must be transported leaving it resting on the feet on a level surface. The movement is carried out by lifting it from the crossbeams of the bench, then placing it gently on the ground, without knocks.

Or by lifting it by means of a harness with special textile straps for lifting (Fig. 2)



IMPORTANT: Lift the machine by hooking it to all four lifting eyes, so that the load is balanced.

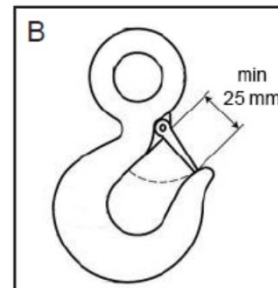
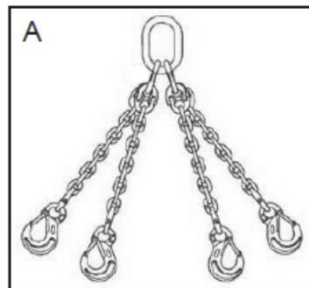
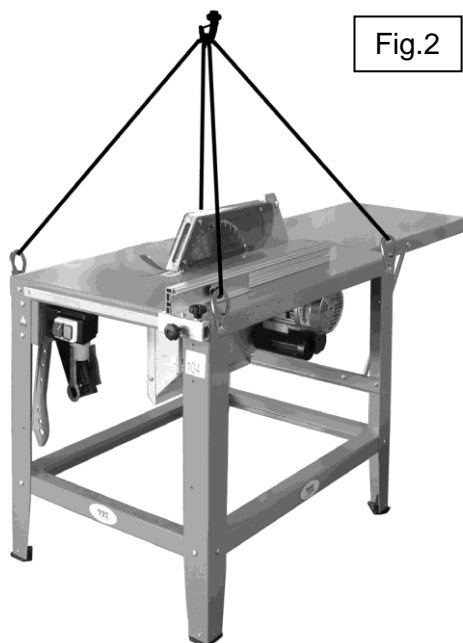

Use 4 repairable lifting chains with these characteristics:

- _ Grade 80(Fig A)
- _ Hook with a minimum opening of 25mm (Fig B)
- _ Lifting capacity of 200Kg minimum
- _ Minimum chain length 170cm

4.3 PRELIMINARY CHECKS

Before inserting the power plug, you need to:

- Place the machine on a stable and level surface to ensure optimal support.
- Check that the state sharpness of the cutting disc is in good condition conditions.
- The blade must be free of cracks or cracks have all teeth at the same length; to be perfectly close and connected.
- Check that the tightening of the nut that fixes the cutting blade between the two flanges is sufficient to guarantee the blocking of the blade itself.
- Make sure that the power socket has the same phase characteristics as the electric motor, and that the power supply line is equipped with a differential switch and magneto-thermal protection (or with a fuse for short circuit max 15 Amp).
- After these preliminary operations, the electrical connection can be made.

IT IS FORBEEDEN TO REMOVE THE PROTECTION

The guards and safety devices must be in place, in good condition and properly maintained. Should faults or defects occur, do not operate the machine until they have been remedied



IT IS FORBEEDEN TO REMOVE THE PROTECTION

The guards and safety devices must be in place, in good condition and properly maintained. Should faults or defects occur, do not operate the machine until they have been remedied

5 - STARTING AND STOPPING

5.1 STARTING AND STOPPING THE MACHINE

The switch is placed in a convenient position and accessible from the operator's workplace. It is of the motor protection type with thermal protection, against current surges and with release coil in the absence of voltage.

For starting

(only after having carried out all the preliminary operations), press the green button (1 Fig. 3).

For normal shutdown

press the red button (2 Fig. 3).

For Emergency stop

press the red button (2 Fig. 3).

The stopping time from the blade is less than 10 seconds, therefore Directive 2006/42 / EC does not provide for an additional emergency device as it does not allow to reduce the risk.

Fig. 5

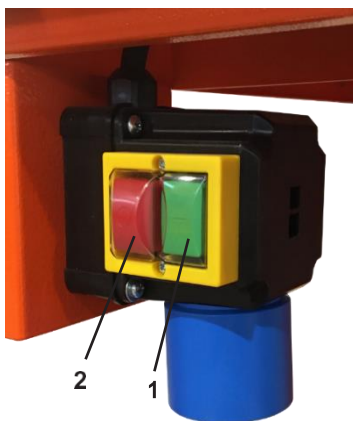

Very important

Always use a 4mm² cable

Three-phase motor rotation inverter

In the socket there is a phase inverter that allows you to change the direction of rotation of the motor: (insert a flat screwdriver, press and rotate 180 °).

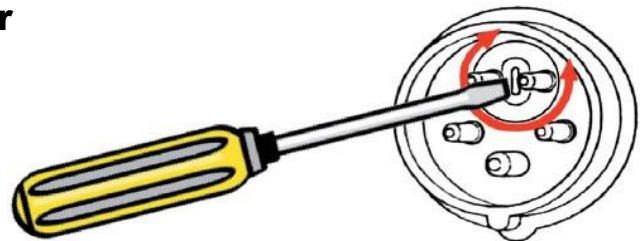

5.2 INSTRUCTIONS FOR USING THE ELECTRICAL EQUIPMENT

Please observe the following warnings:



Do not operate the appliance if the power cable, motor cable or switch show visible damage.



Turn off the switch before carrying out any maintenance, adjustment or repair work and unplug the power cord from the socket. Wait until the blade has completely stopped.



GICs equipped with an electronic brake maintain voltage on the motor even after it has been switched off.

- Check it out the power cord before connecting. Incorrect connections can cause the destruction of the electrical system.
- Observe the mains voltage. The data indicated on the motor identification plate must correspond to the data of the electrical network.
- Only connect electronic equipment to a power cord with sufficient overload protection.



In the event of a prolonged break from work without the operator being absent or if the machine is switched off, the plug of the power supply cable must be removed from the socket (main switch function).



- Connecting the GIC to the motor can only be done by a qualified specialist.

In the event of a power failure, the electric brake does not work. Therefore the machine cannot be put into operation without an operator. Do not insert your hands into the danger zone.

Avoid short switching cycles. The high thermal stress that occurs in the event of frequent starting and braking operations can damage the motor. The switch and the electronic brake.



For the mod. single phase:

- Please note that use is not continuous, therefore the machine must be used in alternating times: 10 minutes of work and 15 minutes of pause.



Operation with a generator is not recommended in principle. Strong voltage fluctuations and spikes are a particular danger to switches that contain electronic components.



We decline all responsibility for damage caused by failure to comply with what specified above.



Explanation of terms:

GIC = plug switch assembly

 **= failure to comply with the warning can cause damage to people and the machine as well as material damage.**

5.3 ANOMALIES AND REMEDIES

ANOMALY	POSSIBLE CAUSE	REMEDY
The engine does not start after pressing the start button	Bad connection	Check the connection
	No mains voltage	Check the mains voltage
	The motor protection has tripped	Start the engine again after a sufficient cooling period (when the engine is no longer hot)
After the drive start button the engine runs in the wrong direction	The rotating field of the cable power supply is incorrect	Turn the phases using a polarity switch (if existing)
	Motor connection is not correct	Check the connection of the motor
After the operation the engine hums and does not reach the rated speed	In the mains power cable a phase is missing	Check the cable supply
	The motor is not wired correctly	Check the motor connection
When the power cable is inserted, the mains fuse trips	Wrong connection (phase and neutral swapped)	Check the connection: for safety reasons, send the circuit breaker to the manufacturer for inspection
	The power semiconductor is defective (switch with electronic brake)	Check the connection: for safety reasons, send the circuit-breaker to the manufacturer for inspection or repair
	Defective power cord	Check the power cord
The machine turns off suddenly during operation	The motor protection has tripped	Start again after a sufficient cooling period. (when the engine is no longer warm)
	Mains voltage interruption	Check the mains voltage. Check the mains protection fuse.
	The mechanical parts of the machine do not turn well	Perform maintenance on the affected parts
After switching off, the engine hums for about 10-15 seconds	When the machine is switched off, the electronic brake is activated for about 10, max 15 seconds, after which it switches off automatically	Normal operating state (hum is caused by the electronic brake)
Electronic brake no longer switches off (permanent hum)	A component on the electronic brake has failed	Pull out the plug of the power supply cable to avoid overheating of the motor. Return the circuit breaker to the manufacturer for repair or replacement

ANOMALY	POSSIBLE CAUSE	REMEDY
<p>After switching off, the flywheel of the circular blade is braked too fast or too much slowly exceeding 10 seconds</p>	<p>Electronic brake adjustment is not ideal</p>	<p>Change the position of the jumper or the potentiometer on the electronic brake until you have an ideal adjustment of the effect and of the braking time</p>
		<p>Do not overcome the maximum absorption of braking</p>
		<p>Before carrying out any work on the switch, the plug of the power supply cable must be removed</p>
		<p>The interventions can only be carried out by qualified specialists</p>
<p>There is no braking.</p>	<p>See the above</p>	
	<p>The electronic brake has failed</p>	<p>Return the circuit breaker to the manufacturer for repair or replacement</p>
<p>Other anomalies</p>	<p>Contact our customer service department or send the defective switch (complete with cable and without motor) together with a brief description of the anomaly that occurred</p>	

5.4 BLADE COVER CAP

The upper part of the blade is protected by a "patented" self-adjusting blade guard. This prevents accidental contact of the worker with the blade and splinters. The anterior cap is equipped with a plate of optically transparent material, (3 Fig. 6), which makes the cutting line visible.

The blade guard is fixed to the wedge-shaped bracket, and the dividing knife is at a maximum distance of 3 mm from the teeth of the blade.

These organs must always be kept in order and in perfect working order. The part of the blade under the work surface is completely closed in a special casing, in which the slot for unloading the chips is obtained. The machine must be used outdoors.

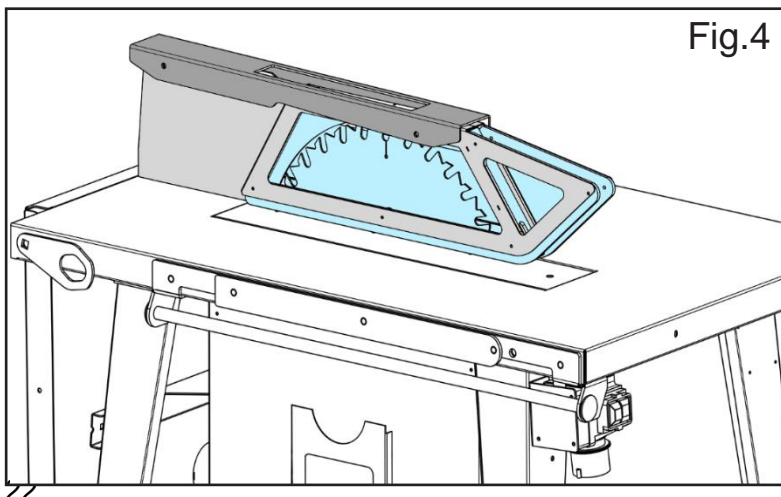

It's forbidden to remove or damage the blade protection.

6 - USE OF THE MACHINE

6.1 USE OF THE CIRCULAR SAW

Wood is a not very regular material: the same piece can have more or less hard, more or less healthy areas, with irregular pattern, knots, etc.

A careful examination of the piece is always necessary before putting it in the car.

It is forbidden to cut material other than wood and its assimilates.

For cutting boards: keep your hands asafety distance, advance regularly without swinging, holding the wood so as to open the cut itself (Fig. 5).

To cut narrow or long planks, at a safe distance, to finish the cut, use the special pushers supplied with the machine (Fig. 6).

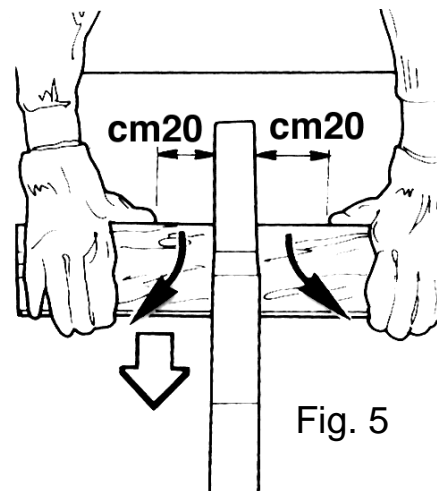

IMPORTANT:during work not distract yourself, keep your hands away from the cutting line to prevent them from bumping against the blade. To cut small pieces, use special pushers with handles (fig. 6)

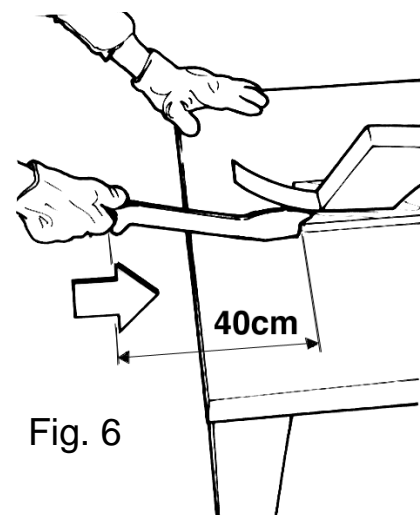

6.2 CUTTING DISC

The blade has a diameter of 450 mm and has a maximum projection above the bench of 155 mm. (Fig.7)

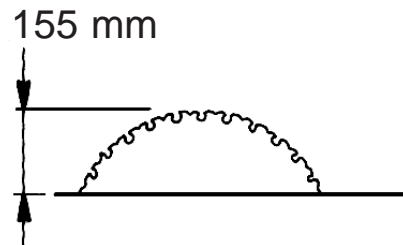



IT IS STRICTLY FORBIDDEN TO CHANGE THE DIAMETER OF THE BLADE. THE MACHINE HAS BEEN DESIGNED FOR THE EXCLUSIVE USE OF A Ø 450 mm DISC, WITH A Ø 30 mm HOLE, THICKNESS 4,4/3,0 mm.



DURING WORK: DO NOT USE YOUR HANDS TO CLEAN THE WORKTOP, USE A BRUSH WITH HANDLE, OR A WOODEN CUT AND IN ANY CASE WITH THE ENGINE OFF.



DURING MAINTENANCE:
USE STURDY GLOVES TO HANDLE THE BLADE. IF THE BLADE IS OUT OF USE DUE TO ANOMALIES, REPORT IT WITH A NOTICE PAPER.



PAY ATTENTION, TO PEOPLE WHO TRY TO USE THE SAW WITHOUT ANY INFORMATION ABOUT IT.

6.3 USE OF THE SQUARE GUIDE

The machine is equipped with a parallel square to perform longitudinal cuts. After setting the measurement (ENGINE OFF),

lock the square with the special locking knob (1 Fig.8).

The square can be adjusted longitudinally by releasing the knob (2 Fig. 8).

The square can also be used in the lowest measure by changing the position of the knob 5 (2 Fig.9).

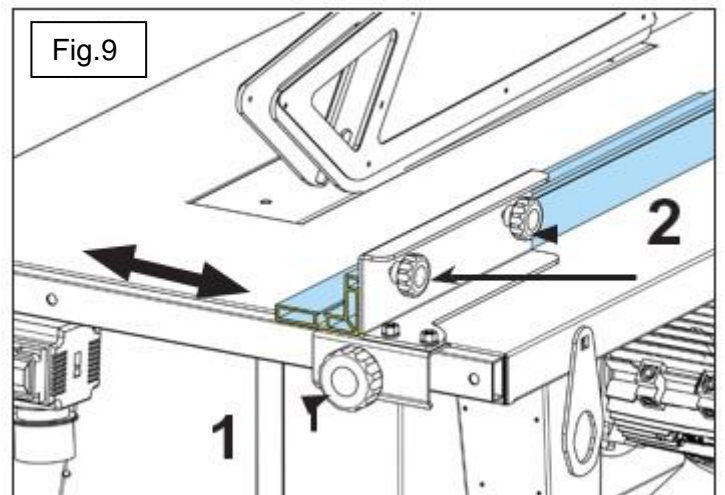
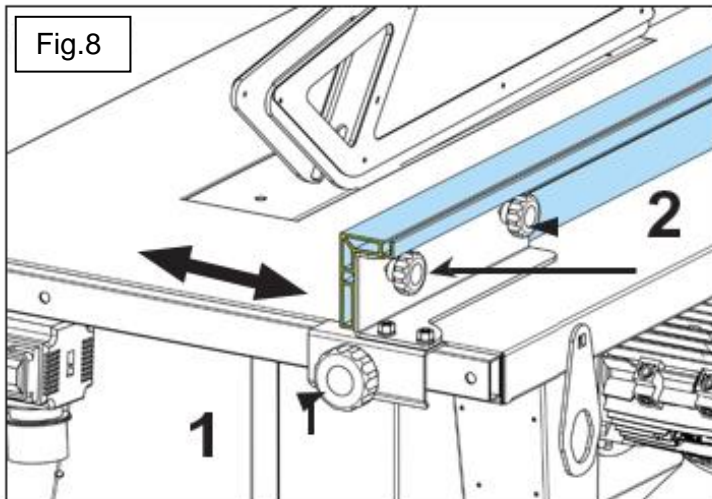

To use the transversal square, proceed to the desired angle by acting on the knob (a fig. 12).

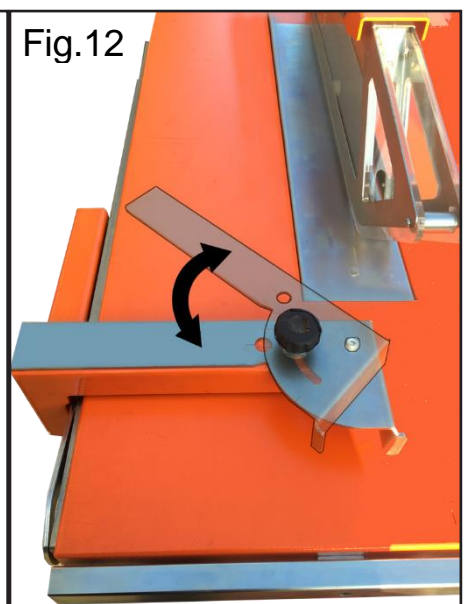
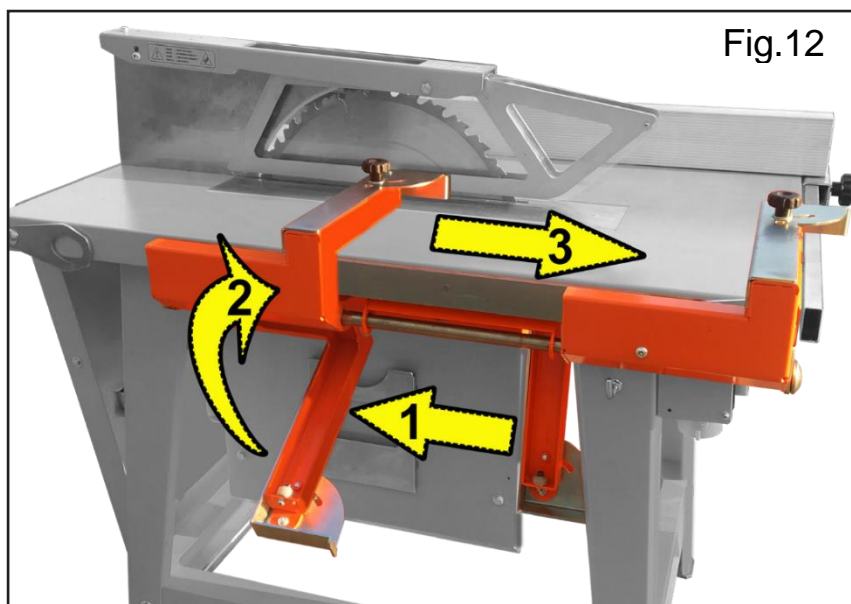

6.4 LONGITUDINAL AND SIDE PUSHER

To avoid accidental contact and to prevent your hands from getting close to the teeth of the blade, you must use the special pushers supplied.

The machine is equipped with two types of pushers:

- **The longitudinal pusher** (Fig. 11), allows you to guide the advancement of long sawn narrow boards.
- **The side pusher** (Fig.12, Fig.13), allows you to guide the pieces tight against the square. In addition, the tip of the side pusher should be used to remove the small scraps left near the blade.
- **Use pushers at the same time** to avoid the risk of injury(Fig.14).

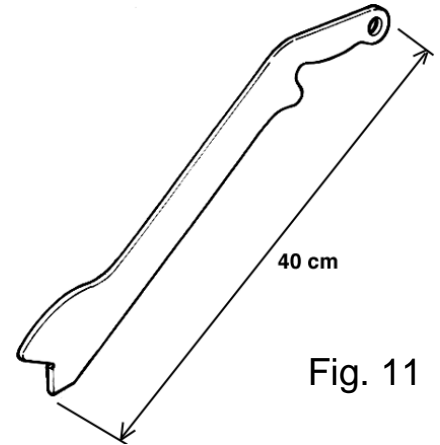

Fig. 11

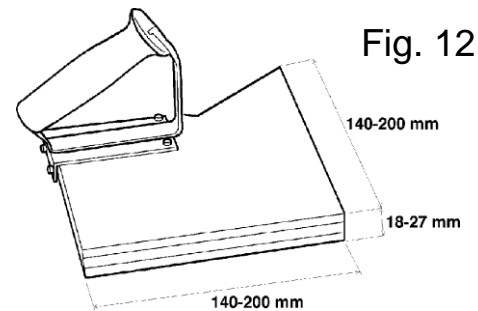

Fig. 12

Using the angle square it is possible to build wedges by adjusting the distance between the wood support and the blade, using the parallel square for longitudinal cuts. If necessary, build a wedge pusher (Fig. 15).



ATTENTION:
FOR CUTTING WEDGES
THEY MUST OPERATE ONLY
TRULY ABLE PEOPLE

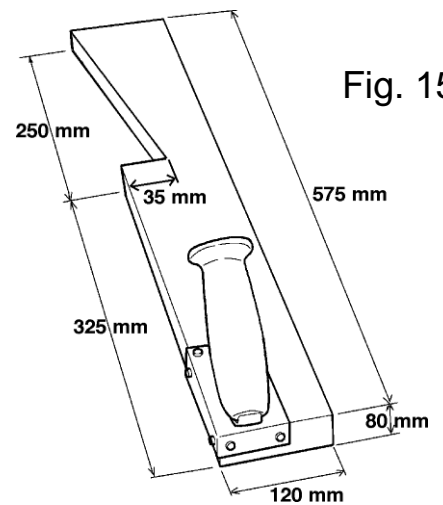

Fig. 15

These protective devices must be used for any cutting job, even if the cut is short-lived. Small errors and inaccuracies in the registration of protective devices (pushers, teams, etc.), can be the cause of an injury.

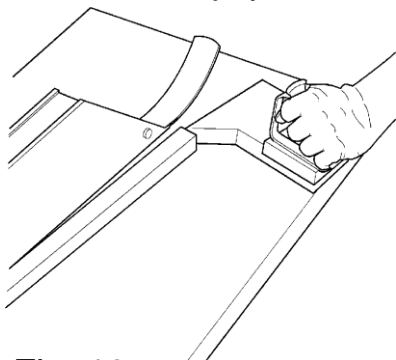

Fig. 13

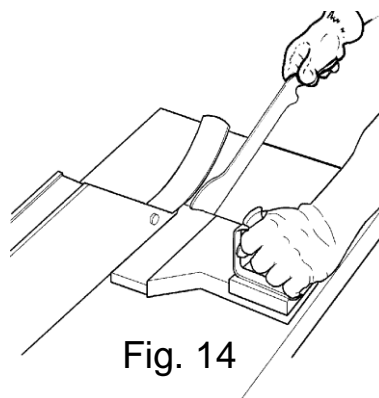
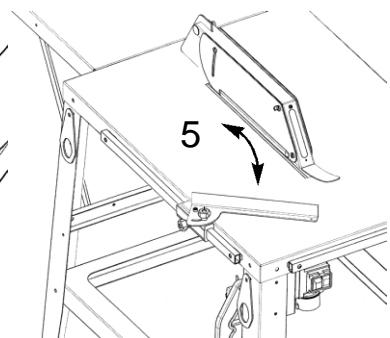

Fig. 14



6.5 EXTENSION OF THE WORK BENCH

The machine is supplied with an extensible workbench that allows a support in the case of cutting long boards.

If you need to cut an excessively long board, use an additional stand to be positioned on the opposite side of the operator, to accommodate the board after cutting (Fig. 16).

TABLE EXTENSION

Lift the extension until it reaches the table top, and hook the support into its seat on the frame crosspiece (1 Fig. 17).

To lower the extension, lift the top and unhook the support from the crosspiece and lower the extension without sudden blows.

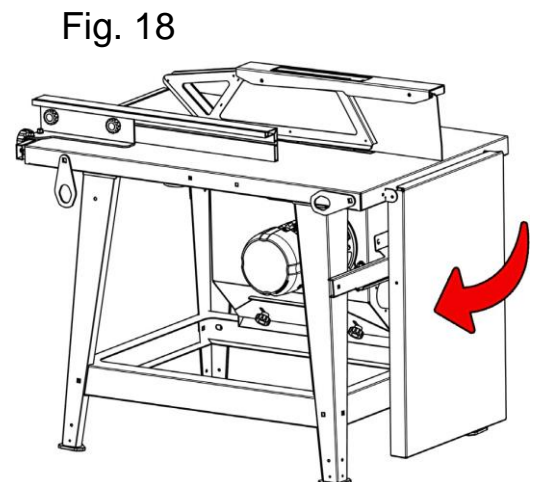
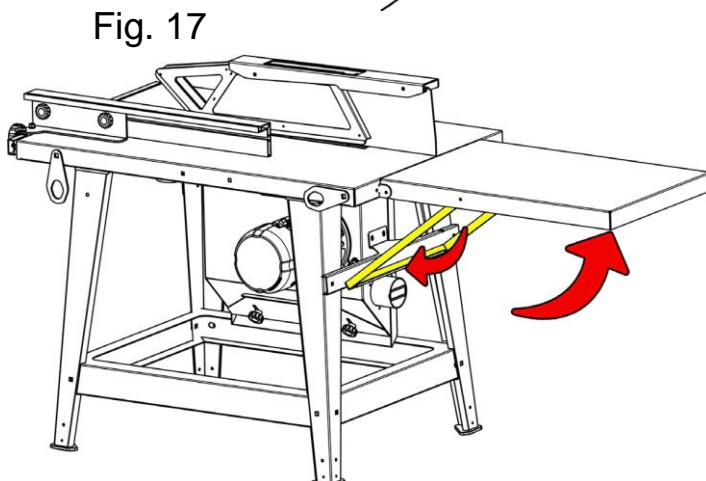
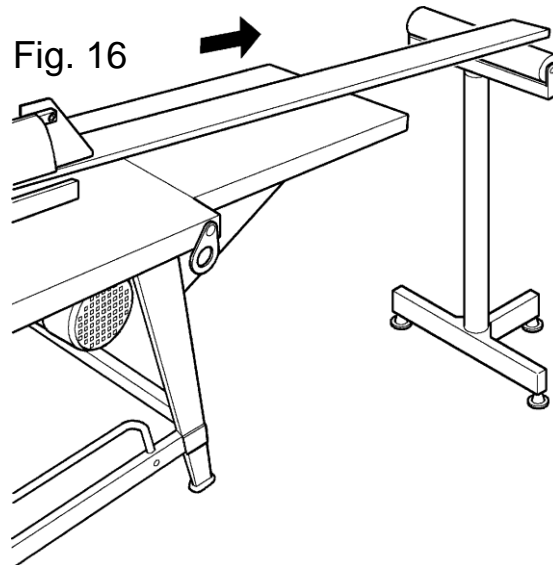

6.6 STABILITY OF THE MACHINE (Fig 19)

If you have to make cuts on large panels, it is necessary to place special sliding supports next to the machine and fix the machine itself on two large axes sp. 50 mm with a length of 3 meters, in order to avoid the risk of overturning due to the cantilevered weight of the panel to be cut.

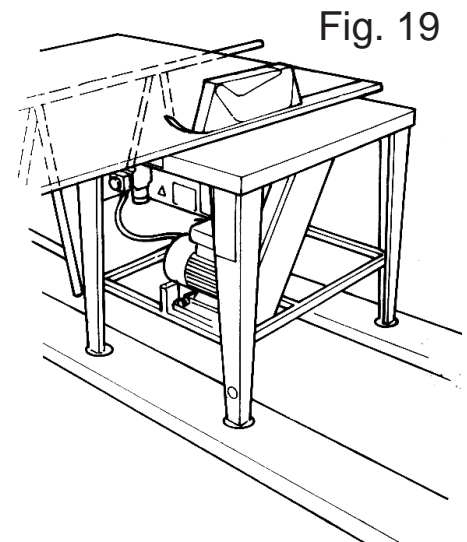

Fig. 19

6.7 CHIP DISCHARGE SLOT AND SUCTION MOUTH

The machine is equipped with a \varnothing 80mm suction mouth for connecting an aspirator (a Fig.20A).

When using the suction it is always necessary to close the slot by means of the closure (b Fig.20B) by acting on the two knobs.

IMPORTANT:

When the aspirator is not connected, the slot must be opened by lifting the closure (b Fig.20B) by acting on the two knobs.

Periodically check that the slot is not blocked by chips.

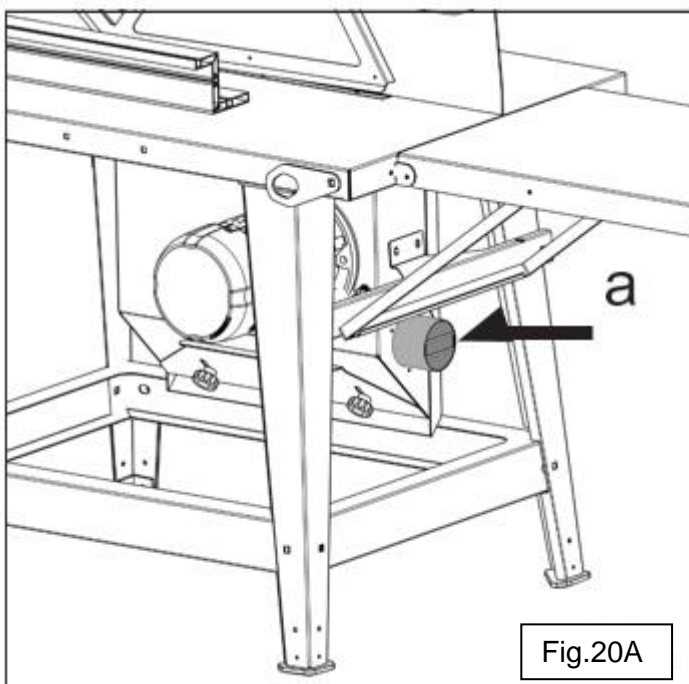

Fig.20A

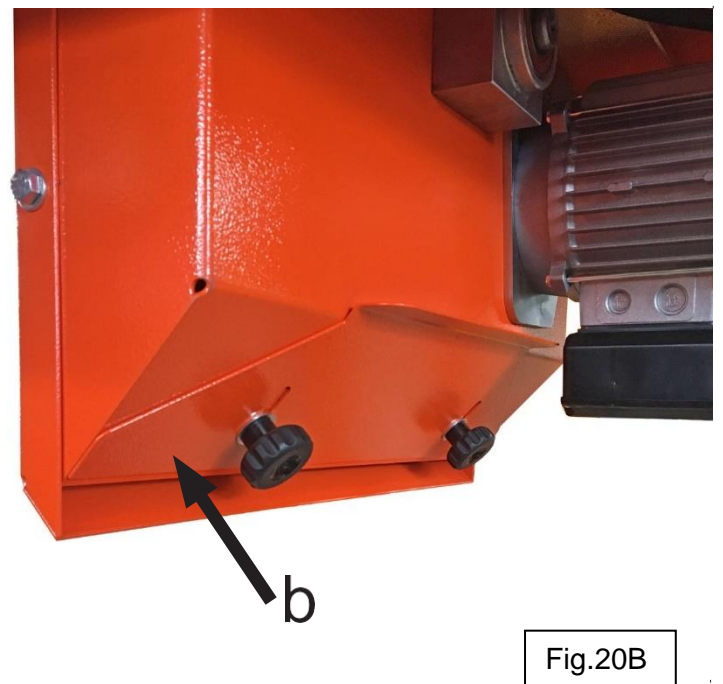
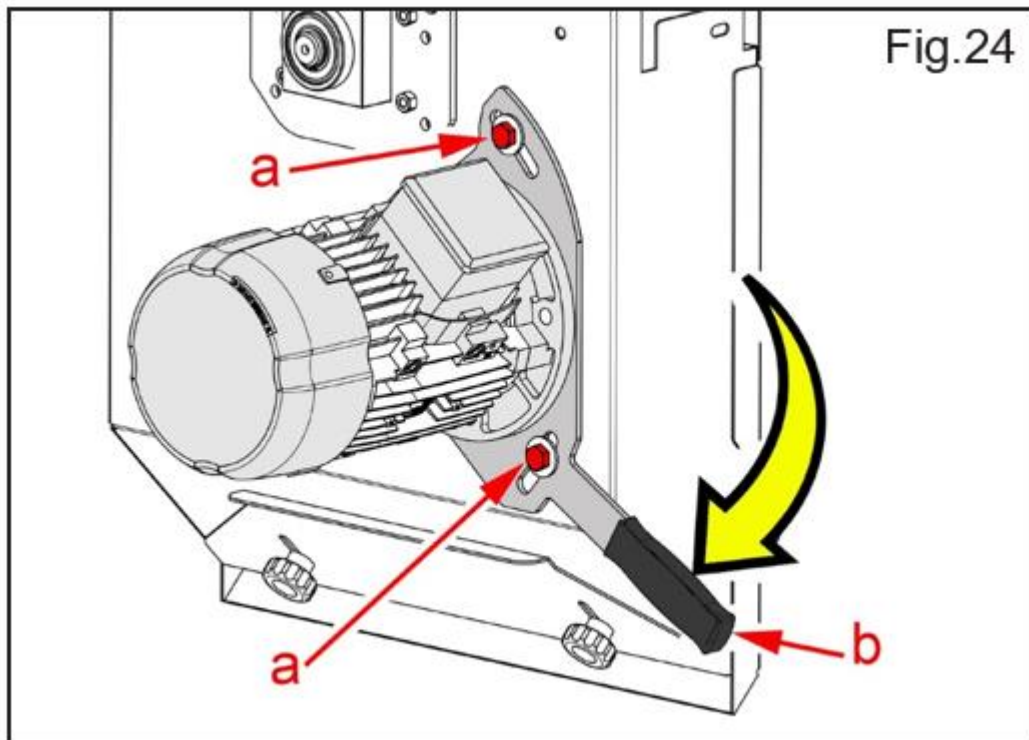

Fig.20B

7 - MAINTENANCE

7.1 REPLACEMENT OF THE BELT

Check the tension of the transmission belts as indicated .



ATTENTION:
THESE OPERATIONS MUST BE
CARRIED OUT WITH THE POWER
SOCKET OFF

7.2 REPLACEMENT OF THE BLADE

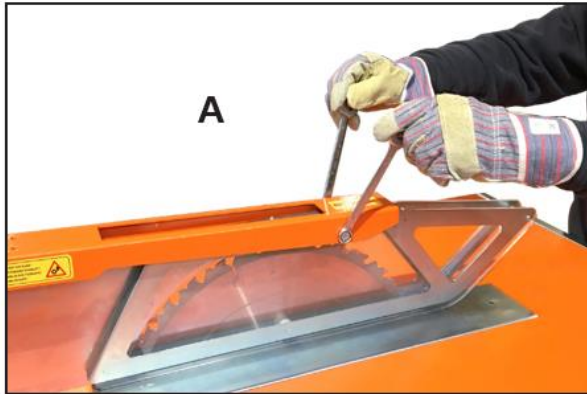

1- Using two wrenches of 13, unscrew and extract the screw, paying attention that the support (A), being pushed by the springs, rises.



2 -Remove the blade protection.

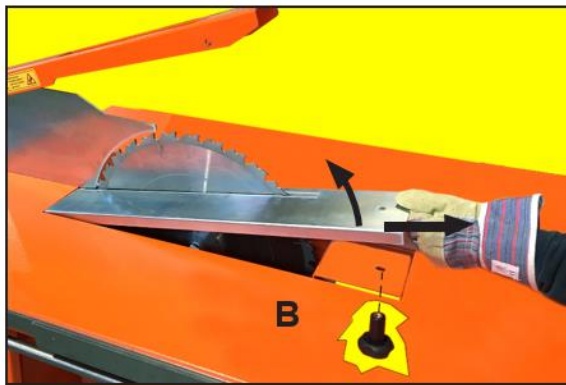

3- Unscrew the knob (B) located under the counter. Lift and extract the blade insert.

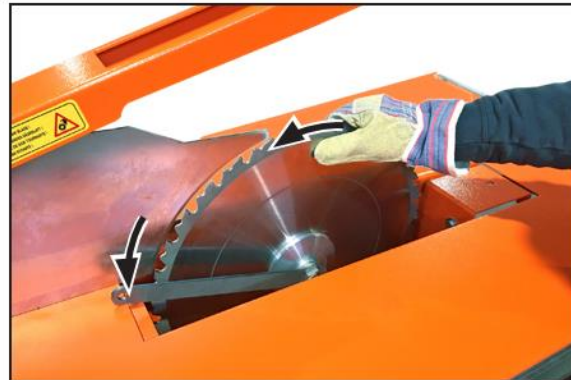

4- Unlock the nut using the supplied wrench. Rotate the blade to the left by making light strokes and banging the key on the bench.



5- Unscrew the nut and remove the flange. The nut has a left-hand thread. Extract the blade upwards.



6- Assemble the blade, the flange and the nut. Lock the nut using the supplied wrench, rotate the blade to the right by making small strokes while hitting the wrench on the bench.



ATTENTION:
THESE OPERATIONS MUST BE
CARRIED OUT WITH THE POWER
SOCKET OFF

All models are fitted with a 450 mm, hole Ø30,
thickness 4.4/3 , Z36

It is not recommended to use blades with reduction rings.

Fig. 26

M arcade: Blade 450 mm,
hole Ø30, thickness 4.4/3 ,
Z36
Distance between knife and
blade 3mm



**IT IS FORBIDDEN TO CHANGE
THE DIAMETER OF THE BLADE
FOR SAFETY REASON.**

The exit divider wedge is adjusted so that it has a
distance of 3 mm on the circumference of the
cutting disc (Fig. 22).

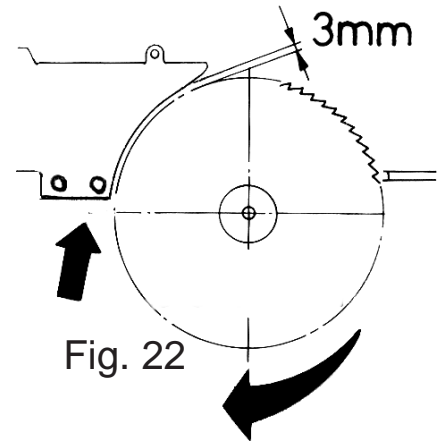

7.3 BRAKING TIME



**DO NOT USE THE MACHINE IF
BRAKING IS INEFFICIENT**

Braking control test:

- To boot the motor and allow at the lama
from reach the maximum rotation speed;
- Switch off the engine with the stop button.
- Check the stopping time with a stopwatch that
does not exceed 10 sec.
- If there is inefficient braking, ask the
manufacturer for the original spare part.

7.4 DESCRIPTION OF THE PERIODIC CHECKS TO BE CARRIED OUT ON THE MACHINE BEFORE USE

CONTROLS DESCRIPTION	CHECK FREQUENCY
Before using the saw, check if the machine has any damaged parts. Before starting work, check the position of the work area: (clutter can cause personal injury)	Whenever the machine is used
Check the direction of rotation of the blade, the teeth must point towards the front of the machine (working position)	Whenever the machine is used
Check the sharpness of the blade (worn blade creates engine damage)	Whenever the machine is used
Check that the blade braking time is less than 10 sec.	Whenever the machine is used
Check that all adjustments are locked before start work	Whenever the machine is used
Always check all the protections, that they are working properly	Whenever the machine is used
Check that the pushers are in order	Whenever the machine is used
Always check the chip extractor, the blade compartment must never be clogged	Whenever the machine is used
Check the screws of the lifting eyes	Each time the machine is lifted
Check the drive belts and pulleys	Every 10 days
EXTRAORDINARY MAINTENANCE Check the blade shaft bearings; Check all the welds and all the tightening screws of the structure, the motor, the switch and all the protections, to be carried out in a suitably equipped workshop with specialized personnel.	Every 15 days

7.5 DISMANTLING

If you decide to dismantle the machine in question, it will be sufficient to electrically disconnect the machine. All parts of the machine must be scrapped and disposed of according to the laws in force in the place where the demolition is carried out.

The machine does not require special precautions, as it does not have toxic components.

8- TRI-PHASE WIRING DIAGRAM

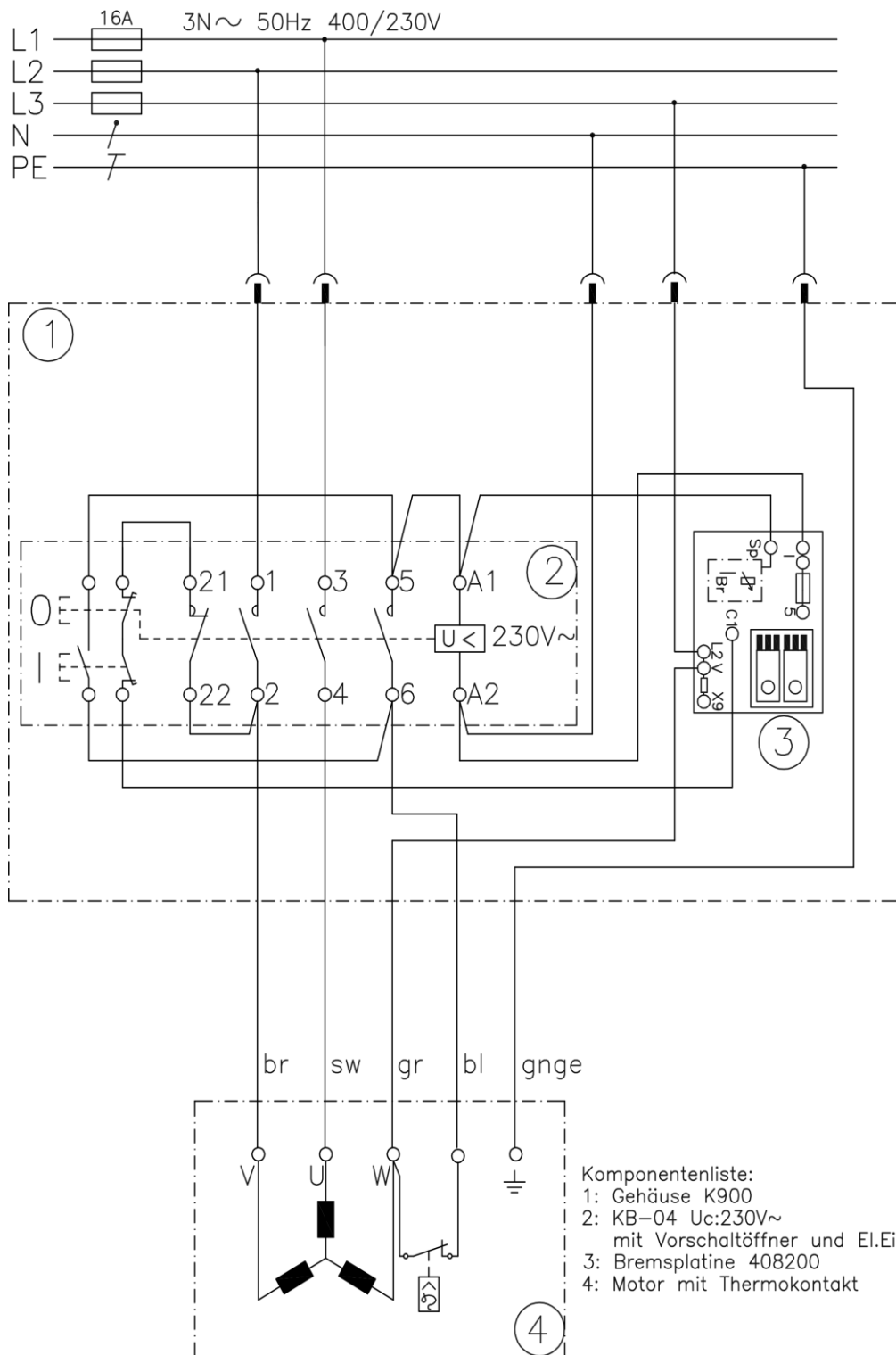

- Komponentenliste:
 1: Gehäuse K900
 2: KB-04 U_c:230V~
 mit Vorschaltöffner und EI.Ein
 3: Bremsplatte 408200
 4: Motor mit Thermokontakt

Customer service

When ordering spare parts, please mention:

- The serial number (7 digits).
- The code of the part.
- The exact denomination.
- The number of parts required.
- The delivery address.
- Please indicate clearly the means of transportation required such as "express" or "by air". Without specific instructions, we will forward the parts through the means which seem appropriate to us --- but which is not always the quickest way.

Clear instructions will avoid problems and faulty deliveries.

If not sure, please send us the defective part.

In the case of a warranty claim, the part must always be returned for evaluation.

Spare parts for the motor can be ordered with the manufacturer of the motor or with their dealer, which is often quicker and cheaper.

This machine has been manufactured by: Saint-Gobain Abrasives S.A.

190, Bd. J. F. Kennedy

L- 4930 BASCHARAGE

Grand-duché de Luxembourg.

Tel.: 00352-50 401-1

Fax: 00352- 50 16 33

<http://www.construction.norton.eu>

e-mail: sales.nlx@saint-gobain.com

Spare parts

In order to consult the spare parts lists, we invite you to visit the after-sales website of Norton Clipper by using the following address:

<https://spareparts.nortonabrasives.com>

For a quick access, you can also use the QR Code shown below using your mobile phone:



This electronic catalogue provides exploded views and spare parts lists for different machines designed by Norton Clipper so you can find references you need.

Guarantee can be claimed and technical support obtained from your local distributor where machines, spare parts and consumables can be ordered as well:

SAINT-GOBAIN ABRASIVES
INDUSTRIEWEG 21
9420 ERPE-MERE
BELGIUM
TEL: +32(0) 2 267 21 00

SAINT-GOBAIN CONSTRUCTION
PRODUCTS CZ A.S
DIVIZE ABRASIVES
SMRČKOVA 2485/4
180 00 PRAHA 8
CZECH REPUBLIC
TEL: +420 255 719 326
FAX: +420 255 719 321

SAINT-GOBAIN ABRASIVES A/S
DYBENDALSVÆNGET 2,
DK-2630 TAASTRUP
DENMARK
TEL: +45 4675 5244

PO BOX 643706
FORTUNE TOWER OFFICE 2106
JLT BLOCK C
(NEXT TO METRO STATION)
JUMEIRA LAKE TOWER, DUBAI
UNITED ARAB EMIRATES
TEL: +971 4 431 5154
FAX: +971 4 431 5434

SAINT-GOBAIN ABRASIFS
RUE DE L'AMBASSADEUR - B.P.8
78 702 CONFLANS CEDEX
FRANCE
TEL: +33 (0)1 34 90 40 00
FAX: +33 (0)1 39 19 89 56

SAINT-GOBAIN ABRASIVES GMBH
BIRKENSTRASSE 45-49
D-50389 WESSELING
GERMANY
TEL: +49 (0) 2236 703-0
FAX: +49 (0) 2236 703-730

SAINT-GOBAIN ABRASIVES KFT.
1225 BUDAPEST
BÁNYALÉG U. 60/B.
HUNGARY
TEL: +36 1 371 22 50
FAX: +36 1 371 22 55

SAINT-GOBAIN ABRASIVI S.P.A
VIA PER CESANO BOSCONI 4
I-20094 CORSICO MILANO
ITALY
TEL: +39 02 44 851
FAX: +39 02 44 78 266

SAINT-GOBAIN ABRASIVES S.A.
190 RUE J.F. KENNEDY
L-4930 BASCHARAGE
GRAND DUCHE DE LUXEMBOURG
TEL: +352 50 401 1
FAX: +331 83 717 792
NO. VERT (FRANCE): 0800 906 903

SAINT-GOBAIN ABRASIFS, S.A.
2 ALLÉE DES FIGUIERS
AIN SEBAË - CASABLANCA
MOROCCO
TEL: +212 5 22 66 57 31
FAX: +212 5 22 35 09 65

SAINT-GOBAIN ABRASIVES BV
GROENLOSEWEG 28
7151 HW EIBERGEN
P.O. BOX 10
7150 AA EIBERGEN
THE NETHERLANDS
TEL: +31 545 466466
FAX: +31 545 474605

SAINT-GOBAIN ABRASIVES AS
KARIHAUGVEIEN, 89
0186 OSLO
NORWAY
TEL: +47 63 87 06 00
FAX: +47 63 87 06 01

SAINT-GOBAIN HPM POLSKA SP. Z O.O.
UL. NORTON 1, 62-600 KOŁO
62-600 KOŁO
POLAND
TEL: +48 63 26 17 100
FAX: +48 63 27 20 401

SAINT-GOBAIN ABRASIVOS, L. DA
ZONA INDUSTRIAL DA MAIA
I-SECTOR VIII, NO. 122
APARTADO 6050
4476 - 908 MAIA
PORTUGAL
TEL: +351 229 437 940
FAX: +351 229 437 949

SAINT-GOBAIN GLASS
BUSINESS UNIT ABRASIVI
PUNCT DE LUCRU : LOC.VETIS, JUD.
SATU MARE 447355
STR. CAREIULUI 11
PARC INDUSTRIAL RENOVATIO
ROMANIA
TEL: +40 261 839 709
FAX: +40 261 839 710

SG HPM RUS
58, F. ENGELS STR.
STROENIE 2
105082 MOSCOW
RUSSIA
TEL: +74 955 408 355
FAX: +74 959 373 224

SAINT-GOBAIN
ABRASIVES (PTY) LTD
2 MONTEER ROAD
ISANDO 1600
P.O. BOX 67
SOUTH AFRICA
TEL: +27 11 961 2000
FAX: +27 11 961 2184/5

SAINT-GOBAIN ABRASIVOS, S.A.
CTRA. DE GUIPÚZCOA, KM. 7,5
E-31195 BERRIOPLANO (NAVARRA)
SPAIN
TEL: +34 948 306 000
FAX: +34 948 306 042

SAINT GOBAIN ABRASIVES AB
GÅRDSFOGDEVÄGEN 18A
168 66 BROMMA • SVERIGE
SWEDEN
TEL: +46 8 580 881 00
FAX: +46 8 580 881 30

SAINT-GOBAIN INOVATIF MALZEMELER
VE ASINDIRICI SAN. TIC. AS.
ALTAYÇEŞME MAH. ÇAMLI SOK. NO:21
ESAS OFISPARK KAT:9 34843
MALTEPE, İSTANBUL • TURKEY
TEL: 0090-216-217 12 50
FAX: 0090-216-442 40 74

SAINT-GOBAIN ABRASIVES LTD.
UNICORN HOUSE UNIT 1, AMISON CLOSE
REDHILL BUSINESS PARK
STAFFORD ST161WB
UNITED KINGDOM
TEL: +44 1785 279 553
FAX: +44 1785 213 487



Saint-Gobain Abrasifs
190 Rue J.F. Kennedy
L-4930 Bascharage
Grand Duché de Luxembourg
Tel: +352 50 4011
Fax: +331 83 717792
no. vert (France) 0800 906 903

www.nortonabrasives.com/fr-fr