

# CT 601 ME

## OPERATING INSTRUCTIONS

Translation of the original instructions



**NORTON**  
SAINT-GOBAIN®

**clipper®**





## Declaration of conformity

The undersigned manufacturer:

**SAINT - GOBAIN ABRASIVES S.A.**  
**190, BD. J. F. KENNEDY**  
**L-4930 BASCHARAGE**

Declares that this product:

Power Float: **CT 601 ME**

Code : **70184629946**

is in conformity with the following Directives:

- **"MACHINES" 2006/42/CE**
- **"LOW VOLTAGE" 2006/95/CE**
- **"ÉLECTROMAGNÉTIQUE COMPATIBILITÉ" 2004/108/CE**
- **"NOISE" 2000/14/CE**

And the European standard

- **EN 12649 – Concrete compactors and resurfacing**

Valid for machines as of serial number:

70100000

Storage site for the technical documents :

Saint-Gobain Abrasives 190, Bd. J. F. Kennedy 4930 BASCHARAGE, LUXEMBOURG

This declaration of conformity loses its validity when the product is converted or modified without agreement.

Bascharage, Luxembourg, 01/02/2012

Olivier Plenert, executive officer.



# CT601ME

## OPERATING INSTRUCTIONS AND SPARE PARTS LIST

<b>1</b>	<b>BASIC SAFETY INSTRUCTIONS</b>	<b>6</b>
1.1	<i>Symbols</i>	6
1.2	<i>Machine plate</i>	7
1.3	<i>Safety instructions for particular operating phases</i>	7
<b>2</b>	<b>MACHINE DESCRIPTION</b>	<b>8</b>
2.1	<i>Short description</i>	8
2.2	<i>Purpose of use</i>	8
2.3	<i>Layout</i>	8
2.4	<i>Technical Data</i>	9
2.5	<i>Statement regarding the vibration emission</i>	10
2.6	<i>Statement regarding noise emission</i>	11
<b>3</b>	<b>ASSEMBLY AND COMMISSIONING</b>	<b>12</b>
3.1	<i>Tool assembly</i>	12
3.2	<i>Electrical connections</i>	12
3.3	<i>Starting the machine</i>	12
<b>4</b>	<b>TRANSPORT AND STORING</b>	<b>13</b>
4.1	<i>Securing for transport</i>	13
4.2	<i>Transport procedure</i>	13
4.3	<i>Long period of inactivity</i>	13
<b>5</b>	<b>OPERATING THE MACHINE</b>	<b>14</b>
5.1	<i>Site of work</i>	14
5.2	<i>Preparing the site</i>	14
5.3	<i>Floating and finishing operation</i>	14
<b>6</b>	<b>MAINTENANCE AND SERVICING</b>	<b>16</b>
<b>7</b>	<b>FAULTS: CAUSES AND CURES</b>	<b>17</b>
7.1	<i>Fault-finding procedures</i>	17
7.2	<i>Trouble-shooting guide</i>	17
7.3	<i>Circuit diagram</i>	17
7.4	<i>Customer service</i>	18

# 1 BASIC SAFETY INSTRUCTIONS

The CT601ME is exclusively designed for the finishing of wet concrete floors mainly on construction sites.

Uses other than the manufacturer's instructions shall be considered as contravening the regulations. The manufacturer shall not be held responsible for any resulting damage. Any risk shall be borne entirely by the user. Observing the operating instructions and compliance with inspection and servicing requirements shall also be considered as included under use in accordance with the regulations.

## 1.1 Symbols

Important warnings and pieces of advice are indicated on the machine using symbols. The following symbols are used on the machine:



Read operator's instructions



Ear protection and safety goggles must be worn

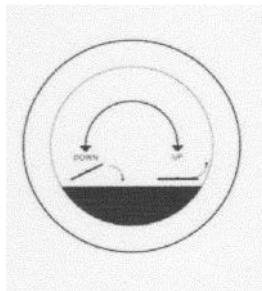

Turn the knob in the indicated direction to tilt (UP) or flatten (DOWN) the blades.



To prevent severe injuries, keep the feet and fingers away from the rotating tool

## 1.2 Machine plate

Important data can be found on the following plate located on the machine:

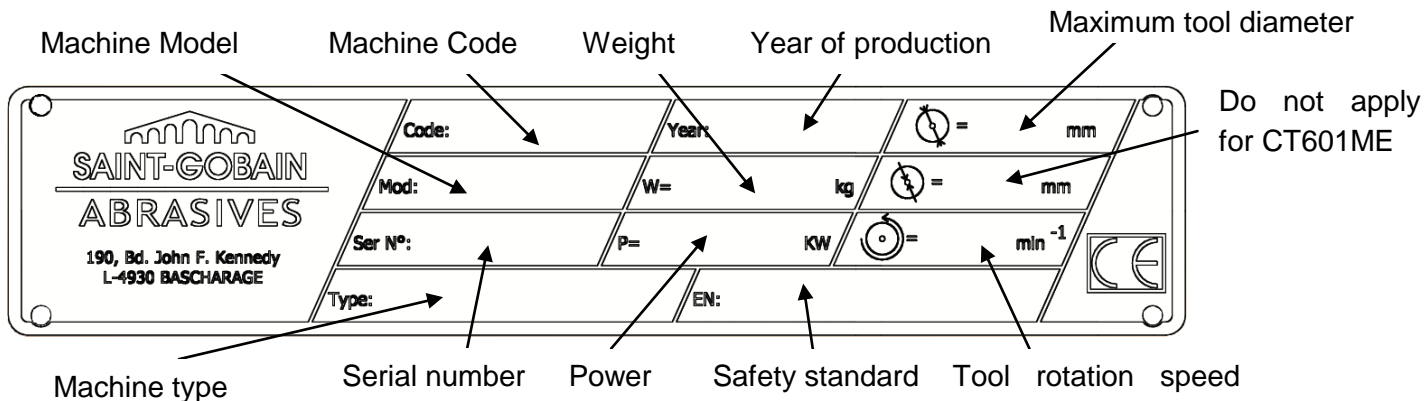

## 1.3 Safety instructions for particular operating phases

### Before commencing work

- Read the present operator's instructions booklet carefully.
- Before commencing work, make yourself familiar with the working environment at the place of use. The working environment includes: obstacles in the area of work and manoeuvre, the firmness of the floor, necessary protection at the site relating to public thoroughfares and the availability of help in the event of accidents.
- Check for correct mounting of the tool regularly.
- Immediately remove damaged or badly worn tools, as they endanger the operator whilst rotating.
- Always use the machine with the safety guard ring, protection guards and electric box cover in position.
- Only fit NORTON blades or plates to the machine! The use of other tools can damage the machine!
- Attention is drawn to the use of BS2092 safety goggles in conformity with specified Processes No.8 of the Protection of Eyes Regulation 1974, Regulation 2(2) Part 1.

### Electrical powered machine

- Always turn off the machine and separate it from the main source of electricity before any work on the machine is done.
- Make all electrical connections securely to eliminate contact of live wires with spray water or dampness.
- It is IMPERATIVE that you earth the machine properly. Let a qualified electrician check in case of doubt.
- In case of emergency, you can stop the machine by releasing the dead-man handle.
- In the event of the machine breaking down or stopping for no apparent reason, switch off the main electricity supply. Only a qualified electrician is allowed to investigate the trouble and remedy the fault.

## 2 MACHINE DESCRIPTION

Any modification, which could lead to a change in the original characteristics of the machine, may be done only by Saint-Gobain Abrasives who shall confirm that the machine is still in conformity with the safety regulations.

### 2.1 Short description

The Mechanical Trowel CT601ME is designed for durability and high performance for onsite finishing operations on wet concrete floors.

As with all other NORTON products, the operator will immediately appreciate the attention given to detail and quality of materials used in construction. The machine and its component parts are assembled to high standards assuring long life and minimum maintenance.

### 2.2 Purpose of use

The Clipper Mechanical Trowel CT601ME is designed for onsite finishing operations on wet concrete floors. It is not designed for any other purpose.

### 2.3 Layout





**Handle (1)**

Jig welded steel construction including 2 rubber grips. A dead-man handle (7) allows the operator to work safely and to stop the machine at any moment. The angle of the machine arm can be adjusted to operate the machine comfortably.

**Pitch of the blades (2)**

The pitch of the blades is controlled over a knob on the handle.

**Belt drive and belt cover (3)**

A centrifugal clutch inside the motor pulley drives the gear shaft through V-Belts. It allows to gradually engage the tool rotation. The drive assembly is enclosed in a metal guard.

**Safety guard ring (4)**

A safety guard ring protects the operator from the rotation of the tool while offering an optimum view of the working progress. This ring can rotate, in order to ease the finishing of floor up to walls.

**Electrical Motor (5)**

Electrical motor with 2,2kW.

**Lifting eye (6)**

To lift the machine easily and safely, a lifting eye is located over the motor. This allows a balanced lifting of the machine.

**2.4 Technical Data**

Electric motor	2,2kW 230V 1~
Electric motor protection	IP55
Max. tool diameter	600 mm
Rotation speed of the tool shaft	130 min <sup>-1</sup>
Sound pressure level	79 dB (A) (ISO EN 11201)
Sound energy level	91 dB (A) (ISO EN 3744)
Type of tool	Blade or plate
Machine dimensions (LxWxH)	1560x650x1060mm
Weight (with tool assembled)	68 kg

## 2.5 Statement regarding the vibration emission

Declared value of vibration emission following **EN 12096**.

Machine Model / code	Measured value of vibration emission at $m/s^2$	Uncertainty K $m/s^2$	Tool used Model / code
CT 601 ME 70184629946	<2.5	0.5	Original Pale

- The vibration value is lower and does not exceed 2.5  $m/s^2$ .
- Values determined using the procedure described in the standard **EN 12649**.
- The measurements are made with new machines. Actual values may vary with site conditions, in terms of:
  - Materials worked
  - Wear Machine
  - Lack of maintenance
  - Inappropriate tool for application
  - Tool in poor condition
  - Unskilled operator
  - Etc...
- The exposure time to vibration is based on the performance of work (related to the adequacy Machine / Tool / worked material / operator)
- When evaluating risks due to hand-arm vibration, you need to take into account effective usage at rated power of machine during a full day of work; quite often you will realise that effective utilisation time represents around 50% of overall duration of work. You have to consider, of course, breaks, water feeding, preparation of work, time to move the machine, disk mounting...

## 2.6 Statement regarding noise emission

Declared value of noise emission following **EN ISO 11201** and **NF EN ISO 3744**.

Machine Model / code	Sound Pressure level $L_{Peq}$ EN ISO 11201	Uncertainty K (Sound Pressure level $L_{Peq}$ EN ISO 11201)	Sound power level $L_{Weq}$ NF EN ISO 3744	Uncertainty K (Sound power level $L_{Weq}$ NF EN ISO 3744)
<b>CT 601 ME</b> 70184629946	79 dB(A)	2.5 dB(A)	91 dB(A)	4 dB(A)

- Values determined using the procedure described in the standard **EN 12649**.
- The measurements are made with new machines. Actual values may vary with site conditions, in terms of:
  - Wear Machine
  - Lack of maintenance
  - Inappropriate tool for application
  - Tool in poor condition
  - Unskilled operator
  - Etc...
- Measured values relate to an operator in normal use, as described in the manual position.

### **3 ASSEMBLY AND COMMISSIONING**

The machine is delivered fully equipped. It is ready for operation after assembly of the tool and adjustment of the machine arm, and after connection to the appropriate power supply.

#### **3.1 *Tool assembly***

Only NORTON blades or plate with a maximum diameter of 600 mm can be used with the CT601ME.

Before mounting a new tool into the machine, switch off the machine and isolate it from the main source of electricity. Make sure the tools are not rotating anymore.

Screw 2 M6-screws per blade using a 10mm wrench to assemble the blade on the arm. To assemble a plate, place the machine with the blades assembled on the plate, and turn it until the blades are located in the hooks on the plate.

#### **3.2 *Electrical connections***

Check that,

- The main switch is on "0".
- The voltage/phase supply corresponds to the information indicated on the motor plate.
- Available power supply must have ground connection in conformity with safety regulations.
- The connecting cables should have at least a 2.5mm<sup>2</sup>-section per phase.

#### **3.3 *Starting the machine***

Set the machine arm in a comfortable position. To that purpose, loosen the handle on the arm and set the arm at the right angle, then retighten the handle.

To start the machine after connection to the power supply, set the main switch on "1" and press the dead-man handle. To stop the machine, release the handle and set the main switch to "0".

## **4 TRANSPORT AND STORING**

### ***4.1 Securing for transport***

Before transporting the machine, always remove the blades and the plate.

### ***4.2 Transport procedure***

Conform yourself to work regulations, in order to transport the machine safely.

To lift the machine, use the lifting eye. Make sure that your lifting device is securely fastened to the lifting eye.

### ***4.3 Long period of inactivity***

If the machine is not going to be used for a long period, completely clean the machine and disassemble the tools. The storage site must be clean, dry and at a constant temperature.

## 5 OPERATING THE MACHINE

### 5.1 Site of work

- Remove from the site anything, which might hinder the working procedure!
- Make sure the site is sufficiently well lit!
- Observe manufacturer's conditions for connecting to power supplies!
- Place electric cables in such a way that damage by the machine is excluded!
- Make sure you have a continual adequate view of the working area so you can intervene in the working process at any time!
- Keep other staff out of the area, so you can work securely.

### 5.2 Preparing the site

Prepare the concrete as for manual trowelling. Assure a well levelled surface (we recommend the use of a beam or better a vibrating screeder). When slab has set sufficiently firm so that the operator can walk on it, leaving only a slight impression (approx.3mm), it is ready for the floating operation.

### 5.3 Floating and finishing operation

To use the machine correctly, you must face it with the two hands on the handle. To start the machine after connection to the power supply, set the main switch on "1" and press the dead-man handle. To stop the machine, release the handle and set the main switch to "0".

#### Handling the machine

Operate the machine from right to left as shown in the following drawing:

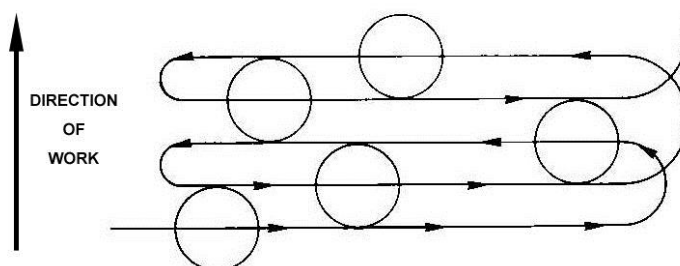

To move the machine:

- Forward (I on the following drawing), turn the handle clockwise.
- Backward (II), turn the handle counterclockwise.
- To the left (III), pull up the handle.
- To the right (IV), push down the handle.

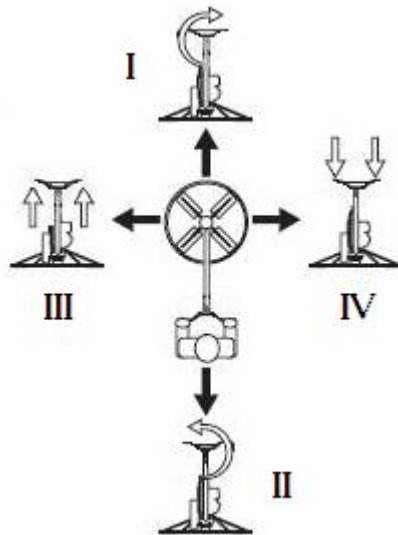

### Tilting the blades

Floating the slab is done with the blades nearly flat on the surface of the concrete; however it is recommended that the blades are just slightly tilted to avoid the suction and drag created in normal operation of float blades on wet concrete. For the finishing operation, tilt the blades. Start with a small pitch of 4 to 6 mm. After each finishing pass, continue to tilt blades.

### Depression or high spot

To fill a depression or cut down a high spot, simply move the machine back and forward over the area until the desired surface is obtained.

**IMPORTANT:** Do not allow the machine to stand in one spot on wet concrete – remove the machine from the slab when it is not used.

**CAUTION:** when the machine is switched off, the tools will continue turning slowly to complete stop. Be therefore very careful to avoid injuries.

## 6 MAINTENANCE AND SERVICING

To ensure a long-term quality from the use of the CT601ME, please follow the maintenance plan below:

		Begin of the day	During the changing of tool	End of the day or more often if required	Every week	After a fault	After a damage
Whole machine	Visual control (general aspect, water tightness)						
	Clean						
Surface of blades or plate	Clean						
Tension of the blade	Check						
Motor cooling fan	Clean						
Motor housing	Clean						
Reachable nuts and screws	Tighten up						

### Maintenance of the machine

Always perform the maintenance of the machine with the machine isolated from the electrical supply and with tools idle.

### Lubrication

The CT601ME uses life-lubricated bearings. Therefore, you don't need to lubricate the machine at all.

### Control and change of the belt

To control the tension of belts, open the belt guard, and push on the belts. You should be able to gape the belt as thick as a finger. If the tension is incorrect, loosen the nuts securing the motor on the machine and move the motor until the correct tension is reached. Make sure that the pulleys are aligned correctly. Then retighten the nuts.

To change the belts, loosen the nuts securing the motor on the machine and move the motor forward until you can remove the old belts and put a new set of belts on the pulleys. Move the motor in order to tighten the belts in a suitable way. Make sure the pulleys are aligned correctly. Then retighten the nuts to assemble the motor securely.

After the control or the change of the belts, always reassemble the belt guard.

### Cleaning of the machine

Your machine will last longer if you clean it thoroughly after each day of work, especially motor and blades or pan.



## 7 FAULTS: CAUSES AND CURES

### 7.1 Fault-finding procedures

Should any fault occur during the use of the machine, turn it off, and isolate it from the electrical supply. Any works dealing with the electrical system or supply of the machine can only be carried out by a qualified electrician.

### 7.2 Trouble-shooting guide

Trouble	Possible source	Resolution
Motor is not running	No electricity	Check the electrical supply (fuse for example)
	Connection cable section too small	Change connection cable
	Defective connection cable	Change connection cable
	Defective switch	CAUTION : can only be solved by qualified electrician
	Defective motor	Change motor or contact motor manufacturer

### 7.3 Circuit diagram

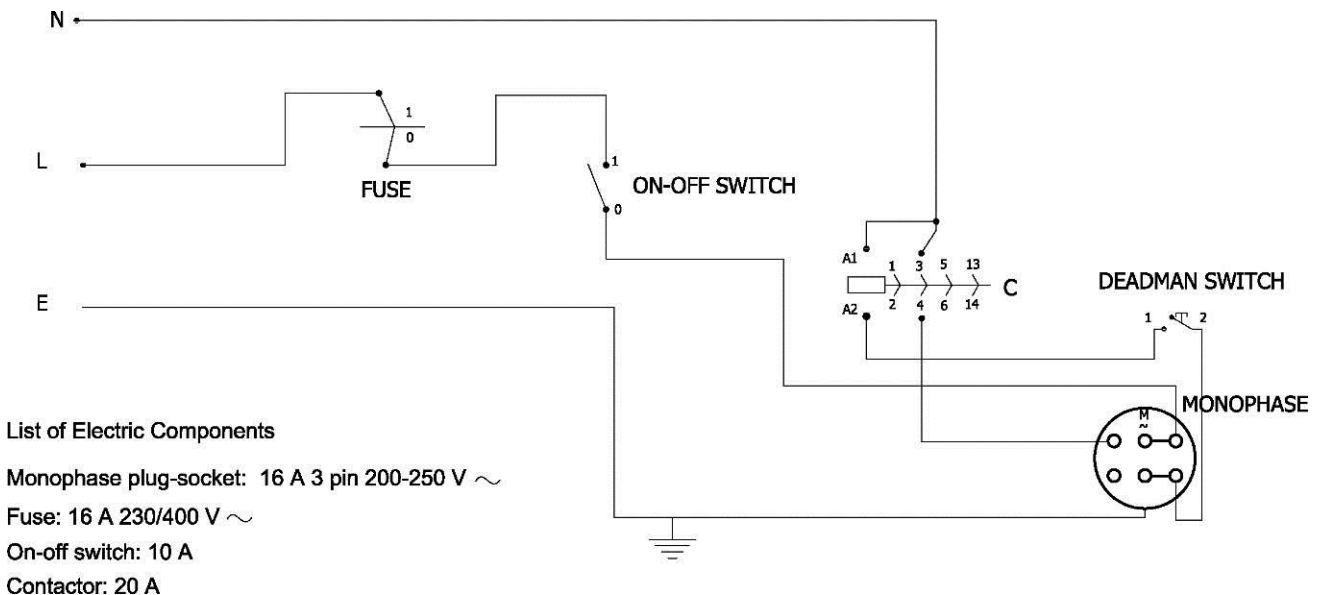

## **7.4 Customer service**

When ordering spare parts, please mention:

- The serial number (7 digits).
- The code of the part.
- The exact denomination.
- The number of parts required.
- The delivery address.
- Please indicate clearly the means of transportation required such as "express" or "by air". Without specific instructions, we will forward the parts through the means which seem appropriate to us --- but which is not always the quickest way.

Clear instructions will avoid problems and faulty deliveries.

If not sure, please send us the defective part. In the case of a warranty claim, the part must always be returned for evaluation. Spare parts for the motor can be ordered with the manufacturer of the motor or with their dealer, which is often quicker and cheaper.

This machine has been manufactured by Saint-Gobain Abrasives S.A.

190, Bd. J.F. Kennedy

L- 4930 BASCHARAGE

Grand-Duché de Luxembourg.

Tel.: 00352-50401-1

Fax: 00352- 50 16 33

<http://www.construction.norton.eu>

e-mail: [sales.nlx@saint-gobain.com](mailto:sales.nlx@saint-gobain.com)

Guarantee can be claimed and technical support obtained from your local distributor where machines, spare parts and consumables can be ordered as well:

SAINT-GOBAIN ABRASIVES NV/SA  
INDUSTRIELAAN 129  
1070 ANDERLECHT/BRUSSEL  
BELGIUM  
TEL: +32 (0)2 267 21 00  
FAX: +32 (0)2 267 84 24

SAINT-GOBAIN ABRASIVES, S.R.O.  
POČERNICKÁ 272/96, MALEŠICE  
108 00 PRAHA 10  
CZECH REPUBLIC  
TEL: +420 255 719 326  
FAX: +420 255 719 321

SAINT-GOBAIN ABRASIVES A/S  
ROBERT JACOBSENS VEJ 62A  
2300 KØBENHAVN S  
DENMARK  
TEL: +45 4675 5244

PO BOX 643706  
FORTUNE TOWER OFFICE 2106  
JLT BLOCK C  
(NEXT TO METRO STATION)  
JUMEIRA LAKE TOWER, DUBAI  
UNITED ARAB EMIRATES  
TEL: +971 4 431 5154  
FAX: +971 4 431 5434

SAINT-GOBAIN ABRASIFS  
RUE DE L'AMBASSADEUR - B.P.8  
78 702 CONFLANS CEDEX  
FRANCE  
TEL: +33 (0)1 34 90 40 00  
FAX: +33 (0)1 39 19 89 56

SAINT-GOBAIN ABRASIVES GMBH  
BIRKENSTRASSE 45-49  
D-50389 WESSELING  
GERMANY  
TEL: +49 (0) 2236 703-1  
+49 (0) 2236 8996-0  
+49 (0) 2236 8911-0  
FAX: +49 (0) 2236 703-367  
+49 (0) 2236 8996-10  
+49 (0) 2236 8911-30

FÜR DEN FACHHANDEL  
ÖSTERREICH  
TEL: +43 (00) 662 430 076

SAINT-GOBAIN ABRASIVES KFT.  
1225 BUDAPEST  
BÁNYALÉG U. 60/B.  
HUNGARY  
TEL: +36 1 371 22 50  
FAX: +36 1 371 22 55

SAINT-GOBAIN ABRASIVI S.P.A  
VIA PER CESANO BOSCONI 4  
I-20094 CORSICO MILANO  
ITALY  
TEL: +39 02 44 851  
FAX: +39 02 44 78 266

SAINT-GOBAIN ABRASIVES S.A.  
190 RUE J.F. KENNEDY  
L-4930 BASCHARAGE  
GRAND DUCHE DE LUXEMBOURG  
TEL: +352 50 401 1  
FAX: +352 50 16 33  
NO. VERT (FRANCE) 0800 906 903

SAINT-GOBAIN ABRASIFS, S.A.  
2 ALLÉE DES FIGUIERS  
AIN SEBAË - CASABLANCA  
MOROCCO  
TEL: +212 5 22 66 57 31  
FAX: +212 5 22 35 09 65

SAINT-GOBAIN ABRASIVES BV  
GROENLOSEWEG 28  
7151 HW EIBERGEN  
P.O. BOX 10  
7150 AA EIBERGEN  
THE NETHERLANDS  
TEL: +31 545 466466  
FAX: +31 545 474605

SAINT-GOBAIN ABRASIVES AS  
POSTBOKS 11, ALNABRU,  
0614 OSLO  
BROBEKKVEIEN 84,  
0582 OSLO  
NORWAY  
TEL: +47 63 87 06 00  
FAX: +47 63 87 06 01

SAINT-GOBAIN HPM POLSKA SP. Z O.O.  
UL. NORTON 1  
62-600 KOŁO  
POLAND  
TEL: +48 63 26 17 100  
FAX: +48 63 27 20 401

SAINT-GOBAIN ABRASIVOS, L. DA  
ZONA INDUSTRIAL DA MAIA  
I-SECTOR VIII, NO. 122  
APARTADO 6050  
4476 - 908 MAIA  
PORTUGAL  
TEL: +351 229 437 940  
FAX: +351 229 437 949

SAINT-GOBAIN GLASS  
BUSINESS UNIT ABRASIVI  
PUNCT DE LUCRU: LOC.VETIS, JUD.  
SATU MARE 447355  
STR. CAREIULUI 11  
PARC INDUSTRIAL RENOVATIO  
ROMANIA  
TEL: 0040-261-839.709  
FAX: 0040-261-839.710

SG HPM RUS  
58, F. ENGELS STR.  
STROENIE 2  
105082 MOSCOW  
RUSSIA  
TEL: +74 955 408 355  
FAX: +74 959 373 224

SAINT-GOBAIN  
ABRASIVES (PTY) LTD  
2 MONTEER ROAD  
ISANDO 1600  
P.O. BOX 67  
SOUTH AFRICA  
TEL: +27 11 961 2000  
FAX: +27 11 961 2184/5

SAINT-GOBAIN ABRASIVOS, S.A.  
CTRA. DE GUIPÚZCOA, KM. 7,5  
E-31195 BERRIOPLANO (NAVARRA)  
SPAIN  
TEL: +34 948 306 000  
FAX: +34 948 306 042

SAINT-GOBAIN ABRASIVES AB  
BOX 495  
SE-191 24 SOLLENTUNA  
SWEDEN  
TEL: +46 8 580 881 00  
FAX: +46 8 580 881 01

SAINT-GOBAIN INOVATIF  
MALZEMELER VE AŞINDIRICI  
SAN. TIC. A.Ş.  
GOLD PLAZA, ALTAY ÇEŞME  
MAHALLESİ, ÖZ SOKAK, NO:19/16  
34843 MALTEPE-ISTANBUL,  
TURKEY  
TEL: 0090-216-217 12 50  
FAX: 0090-216-442 40 74

SAINT-GOBAIN ABRASIVES LTD.  
DOXEY RD  
STAFFORD  
ST16 1EA  
UNITED KINGDOM  
TEL: +44 1785 222 000  
FAX: +44 1785 213 487

[www.construction.norton.eu](http://www.construction.norton.eu)

**Saint-Gobain Abrasives**

190, Bd. J. F. Kennedy  
L-4930 BASCHARAGE  
LUXEMBOURG

Tel: ++352 50401-1

Fax: ++352 501633

e-mail: sales.nlx@saint-gobain.com