

CS 352 B

SPARE PART LIST
LISTE DE PIÈCES DE RECHANGE
ERSATZTEILLISTE



NORTON[®]

SAINT-GOBAIN

clipper[®]

ENGLISH

TYPE:

S = Spare part

W = Wear part

NA = Not Available

The kits of spare parts contain all screws and bolts and the components referring itself to it.

Screws and bolts is component of standard assembly, which you can easily find at all the retailers of standard components of assembly.

All the components of standard assembly are of a quality grade 8.8.

We recommend not to use a quality grade lower than 8.8 for all the standard components of assembly.

The parts of replacements Norton CLIPPER must always be used.

Wear parts life will vary based on usage and maintenance of the machine or part. Wear parts will need to be maintained and replaced as needed. No warranty is applied to wear parts.

The components NA (Not Available) are not available in spare part.

FRANCAIS

TYPE :

S = Pièce de rechange

W = Pièce d'usure

NA = Non disponible

Les kits de pièces détachées contiennent toute la visserie et les composants s'y rapportant.

La visserie est un composant d'assemblage standard, que vous pouvez facilement trouver chez tous les détaillants de composants d'assemblage standards.

Tous les composants d'assemblage standard sont d'une classe de qualité 8.8.

Nous recommandons de ne pas utiliser une classe de qualité inférieure à 8.8 pour tous les composants d'assemblage standards.

Pour les pièces non standard, les pièces de remplacement doivent impérativement provenir de Norton CLIPPER.

La durée de vie des pièces d'usure varie en fonction de l'utilisation et de la maintenance de la machine ou de la pièce. Les pièces d'usure devront être entretenues et remplacées au besoin. Aucune garantie n'est appliquée aux pièces d'usure.

Les composants NA (Not Available) ne sont pas disponibles en pièce de rechange.

DEUTSCH

TYP :

S = Ersatzteile

W = Verschleißteile

NA = nicht verfügbare

Die definierten Ersatzteil-Set's beinhalten alle Ersatzteile wie Komponenten, Schrauben, Muttern etc.

Norm- bzw. Standardteile wie Schrauben, Muttern etc. können bei offiziellen Schrauben- sowie Komponentenhändler bezogen werden.

Alle Norm- bzw. Standardteile wie Schrauben, Muttern etc. entsprechen der Qualitäts- bzw. Festigungsklasse 8.8.

Wir empfehlen, keine Norm- bzw. Standardteile wie Schrauben, Muttern etc. unter der Qualitäts- bzw.

Festigungsklasse 8.8 einzusetzen.

Es dürfen nur geprüfte Norton CLIPPER-Ersatzteile eingesetzt werden.

Die Lebensdauer der Verschleißteile hängt von der Verwendung und Wartung der Maschine oder des Teils ab. Verschleißteile müssen gewartet und bei Bedarf ersetzt werden. Für Verschleißteile wird keine Garantie übernommen.

Ersatzteile sowie Komponenten mit dem Vermerk NA (NA=nicht verfügbar) sind nicht verfügbar.

Pivoting Engine frame / Chassîs pivotant Moteur / Motorrahmen Satz

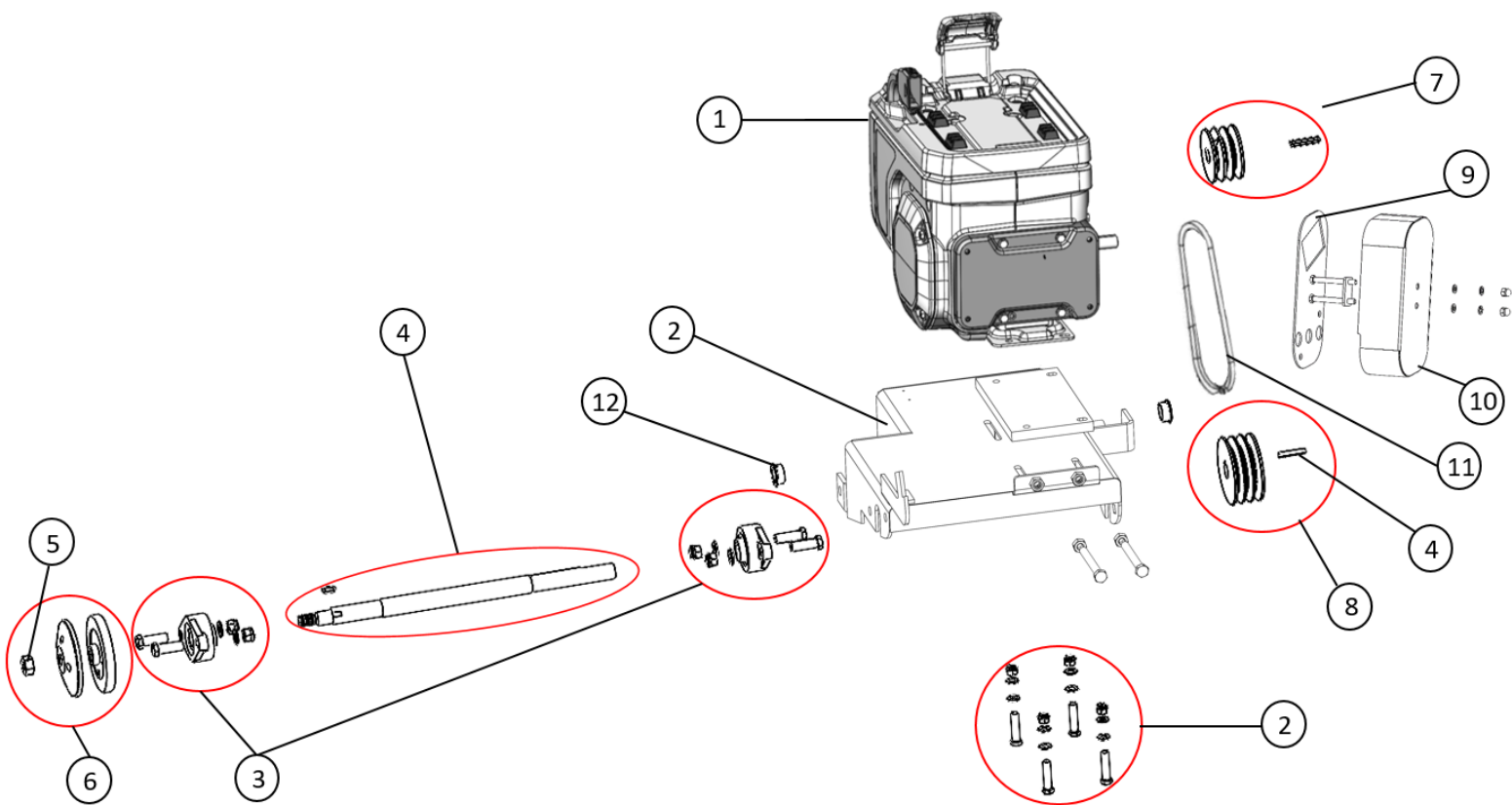

POS.	DESCRIPTION	DESCRIPTION	BESCHREIBUNG	QTY	REF	TYPE
1	Engine HONDA eGX Q2	Moteur HONDA eGX Q2	Motor HONDA eGX Q2	1	310568969	S
2	Pivoting Engine frame kit	Kit Chassis pivotant Moteur	Motorrahmen Satz	1	310589474	S
	Hex screw ISO 4017 - M8 x 40 mm	Vis ISO 4017 - M8 x 40 mm	Schraube ISO 4017 - M8 x 40 mm	4		
	Torque Nut ISO 7040 M8	Ecrou ISO 7040 M8	Mutter ISO 7040 M8	4		
	Engine plate support	Support Moteur	Motorrahmen	1		
	Pivoting engine frame	Support Moteur	Motorrahmen	1		
	Plain washer ISO 7089 - Ø8 mm	Rondelle ISO 7089 - Ø8 mm	Scheibe ISO 7089 - Ø8 mm	8		
	Hex Nut ISO 4032 M10	Vis ISO 4032 M10	Schraube ISO 4032 M10	2		
	Hex screw ISO 4017 - M10 x 45 mm	Vis ISO 4017 - M10 x 45 mm	Schraube ISO 4017 - M10 x 45 mm	2		
3	Bearing FYTB 20 TF Kit	Kit Palier FYTB 20 TF	Lager FYTB 20 TF Satz Kompl.	1	310004907	W
	Bearing FYTB 20 TF	Palier FYTB 20 TF	Lager FYTB 20 TF	1		
	Hex screw ISO 4017 - M10 x 35 mm	Vis ISO 4017 - M10 x 35 mm	Schraube ISO 4017 - M10 x 35 mm	2		
	Plain washer ISO 7089 - Ø10 mm	Rondelle ISO 7089 - Ø10 mm	Scheibe ISO 7089 - Ø10 mm	4		
	Torque Nut ISO 7040 M10	Ecrou ISO 7040 M10	Mutter Nut ISO 7040 M10	2		
4	Blade shaft Kit	Kit Arbre disque	Schneidwelle Satz	1	310574155	S
	Blade shaft	Arbre disque	Schneidwelle	1		
	Parallel Key B6x6x36 DIN 6885	Clavette B6x6x36 DIN 6885	Passfeder B6x6x36 DIN 6885	1		
	Parallel Key Blade 5x5x16	Clavette Disque 5x5x16	Passfeder 5x5x16	1		
5	Hex nut M14	Ecrou M14	Mutter M14	1	310004319	S
6	Flange Kit	Kit flasque	Flansche Satz	1	310574256	S
	Mobile Flange	Flasque mobile	Fester Flansch	1		
	Fixed Flange	Flasque fixe	Looser Flansch	1		
	Hex nut M14 left hand thread	Ecrou M14	Mutter M14	1		
7	Motor pulley Kit	Kit Poulie moteur	Motorriemenscheibe Satz	1	310589475	S
	Motor pulley	Poulie moteur	Riemenscheibe	1		
	Screw DIN 916 M5x10	Vis DIN 916 M5x10	Schraube DIN 916 M5x10	2		
	Parallel Key Motor 4,78x4,78x20	Clavette moteur 4,78x4,78x20	Passfeder 4,78x4,78x20	1		
8	Blade Shaft pulley Kit	Kit Poulie Arbre disque	Riemenscheibe Schneidwelle Satz	1	310589596	S
	Blade Shaft pulley	Poulie Arbre disque	Riemenscheibe	1		
	Screw DIN 916 M8x20	Vis DIN 916 M8x16	Schraube DIN 916 M8x16	2		
	Parallel Key B6x6x36 DIN 6885	Clavette B6x6x36 DIN 6885	Passfeder B6x6x36 DIN 6885	1		
9	Belt Guard Inf Kit	Kit Carter courroies Inf	Festes Riemenschutz Satz	1	310589597	S
	Belt Guard Inf	Carter courroies Inf	Festes Riemenschutz	1		
	Hex Screw ISO 4017-M8x80 N	Vis ISO 4017-M8x80 N	Schraube ISO 4017-M8x80 N	2		
	Torque Nut ISO 7040 M10	Ecrou ISO 7040 M10	Mutter ISO 7040 M10	2		
	Hex screw ISO 4017 - M10 x 25 mm	Vis ISO 4017 - M10 x 25 mm	Schraube ISO 4017 - M10 x 25 mm	2		
	Plain washer ISO 7089 - Ø10 mm	Rondelle ISO 7089 - Ø10 mm	Scheibe ISO 7089 - Ø10 mm	2		
10	Belt Guard Sup Kit	Kit Carter courroies Sup	Beweglicher Riemenschutz Satz	1	310589598	S
	Belt Guard Sup	Carter courroies Sup	Beweglicher Riemenschutz	1		
	Plain washer ISO 7089 - Ø8 mm	Rondelle ISO 7089 - Ø8 mm	Scheibe ISO 7089 - Ø8 mm	2		
	Domed cap nut DIN 1587 M8	Ecrou DIN 1587 M8	Mutter DIN 1587 M8	2		
	Curved spring washer DIN 127 - Ø8	Rondelle DIN 127 - Ø8 mm	Scheibe DIN 127 - Ø8 mm	2		
11	V-Belt XPZ560	Courroie XPZ560	Riemen XPZ560	1	310589599	W
12	Wear ring	Bague d'usure	Wear ring	1	310005502	W

Main frame / Châssis principal / Rahmen

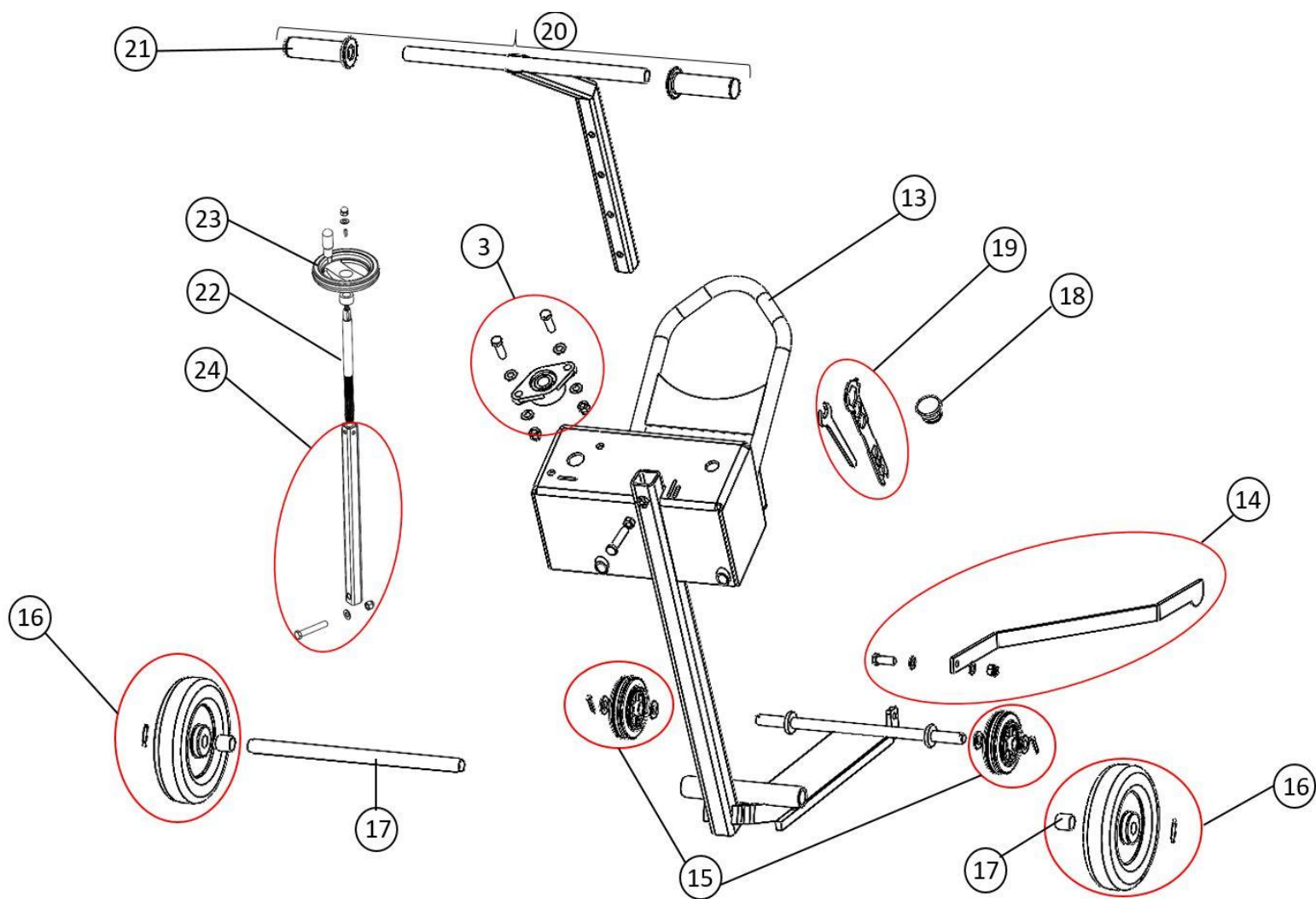

POS.	DESCRIPTION	DESCRIPTION	BESCHREIBUNG	QTY	REF	TYPE
13	Main Frame	Châssis Principal fixe	Grundrahmen	1	310589600	S
3	Bearing FYTB 20 TF Kit	Kit Palier FYTB 20 TF	Lager FYTB 20 TF Satz Kompl.	1	310004907	W
	Bearing FYTB 20 TF	Palier FYTB 20 TF	Lager FYTB 20 TF	1		
	Hex screw ISO 4017 - M10 x 35 mm	Vis ISO 4017 - M10 x 35 mm	Schraube ISO 4017 - M10 x 35 mm	2		
	Plain washer ISO 7089 - Ø10 mm	Rondelle ISO 7089 - Ø10 mm	Scheibe ISO 7089 - Ø10 mm	4		
	Torque Nut ISO 7040 M10	Ecrou ISO 7040 M10	Mutter ISO 7040 M10	2		
14	Cutting Guide Kit	Kit Guide de coupe	Schnittführung, kompl.	1	310574260	S
	Cutting guide	Guide de coupe	Schnittführung	1		
	Hex screw ISO 4017 - M10 x 30 mm	Vis ISO 4017 - M10 x 30 mm	Schraube ISO 4017 - M10 x 30 mm	1		
	Plain washer ISO 7089 - Ø10 mm	Rondelle ISO 7089 - Ø10 mm	Scheibe ISO 7089 - Ø10 mm	2		
	Torque Nut ISO 7040 M10	Ecrou ISO 7040 M10	Mutter ISO 7040 M10	1		
15	Front wheel 100x45 mm Kit	Kit Roue avant 100x45 mm	Vorderrad Satz 100x45 mm	1	310560763	W
	Front wheel 100x35 mm	Roue avant 100x35 mm	Vorderräder 100x35 mm	1		
	Plain washer ISO 7089 - Ø14 mm	Rondelle ISO 7089 - Ø14 mm	Scheibe ISO 7089 - Ø14 mm	2		
	Split pin ISO 1234 4x25 mm	Goupille ISO 1234 4x25 mm	Stift ISO 1234 4x25 mm	1		
16	Back wheel 200x45 mm Kit	Kit Roue arrière 200x45 mm	Hinterrad Satz 200x45 mm	1	310574261	W
	Back wheel 200x45 mm	Roue arrière 200x45 mm	Hinterrad 200x45 mm	1		
	Split pin ISO 1234 4x25 mm	Goupille ISO 1234 4x25 mm	Stift ISO 1234 4x25 mm	1		
	Wear ring 20X23X25 mm	Bague 20X23X25 mm	Wear ring 20X23X25 mm	1		
17	Back Wheel Shaft Kit	Kit arbre roue arrière	Hinterradachse Satz	1	310574262	S
	Back Wheel Shaft	Arbre roue arrière	Hinterradachse	1		
	Split pin ISO 1234 4x25 mm	Goupille ISO 1234 4x25 mm	Stift ISO 1234 4x25 mm	2		
	Wear ring 20X23X25 mm	Bague 20X23X25 mm	Wear ring 20X23X25 mm	2		
18	Urgency Push Stop NC	Stop Urgence NC	Not Aus Schalter NC	1	310589601	S
19	Wrench Kit	Kit clé	Schraubenschlüssel Satz	1	310574263	S
	Wrench 19	Clé 19	Schraubenschlüssel 19	1		
	Multiple wrench	Clé Multiple	Mehrere Schraubenschlüssel	1		
20	Handlebars Sup Assembly Kit	Kit guidon	Bediengriff, kompl.	1	310574264	S
	Handlebars Sup	Guidon	Griffstange	1		
	Rubber Handle Ø20 mm	Poignée	Gummigriff	2		
	Hex screw ISO 4017 - M10 x 55 mm	Vis ISO 4017 - M10 x 55 mm	Schraube ISO 4017 - M10 x 55 mm	1		
	Hex nut ISO 4032 M10	Ecrou ISO 4032 M10	Mutter ISO 4032 M10	1		
21	Rubber Handle Ø20 mm	Poignée	Gummigriff	2	310004190	S
22	Lifting Screw Kit	Kit vis sans fin	Spindelschraube Satz	1	310574265	S
	Lifting Screw	Vis sans fin	Spindelschraube	1		
	Parallel Key A5x5x18 DIN 6885	Clavette A5x5x18 DIN 6885	Passfeder A5x5x18 DIN 6885	1		
	Locking collar + screw M5x8	Bague serrage + vis M5x8	Sicherungsring + Schraube M5x8	1		
23	Steering wheel Kit	Kit Volant	Handrad, kompl.	1	310574266	S
	Steering wheel	Steering wheel	Handrad	1		
	Domed cap nut DIN 1587 M10	Ecrou DIN 1587 M10	Mutter DIN 1587 M10	1		
	Plain washer ISO 7089 - Ø10 mm	Rondelle ISO 7089 - Ø10 mm	Scheibe ISO 7089 - Ø10 mm	1		
24	Square tube Kit	Kit tube	Rohr Satz	1	310574267	S
	Square tube Assy	Assem. Tube	Rohr Assy	1		
	Hex screw DIN 931 - M12 x 100 mm	Vis DIN 931 - M12 x 100 mm	Schraube DIN 931 - M12 x 100 mm	1		
	Plain washer ISO 7089 - Ø12 mm	Rondelle ISO 7089 - Ø12 mm	Scheibe ISO 7089 - Ø12 mm	1		
	Torque Nut ISO 7040 M12	Ecrou ISO 7040 M12	Mutter ISO 7040 M12	1		

Blade guard / Carter de disque / Plattegehäuse

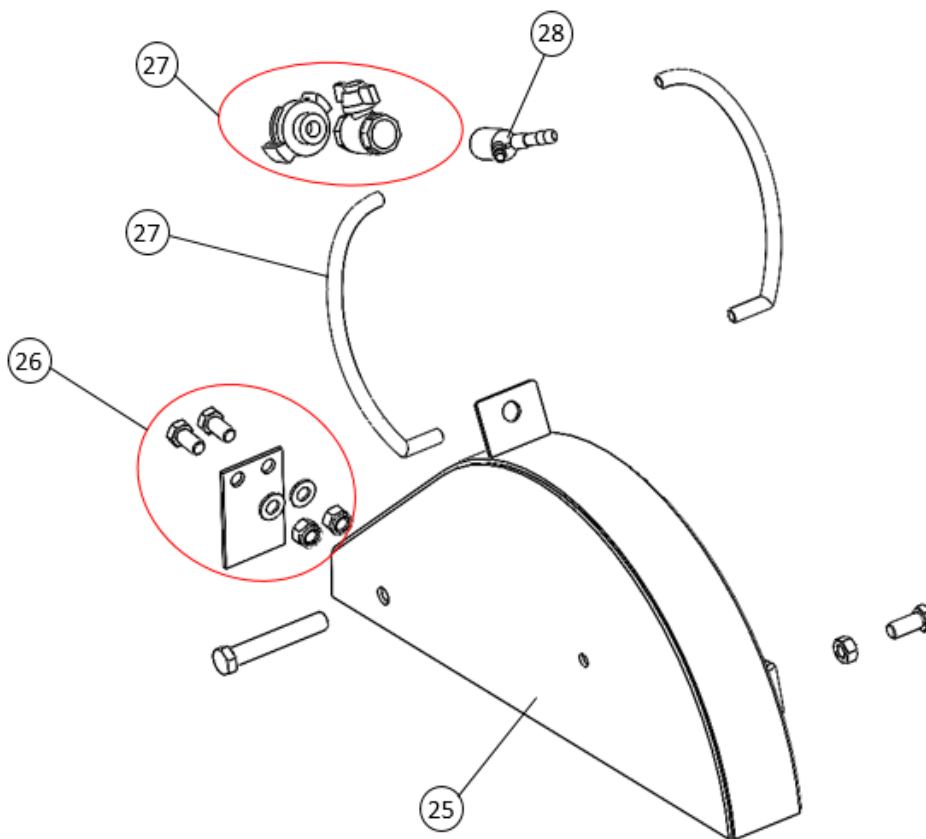

POS.	DESCRIPTION	DESCRIPTION	BESCHREIBUNG	QTY	REF	TYPE
25	Blade Guard Kit	Kit Carter disque	Sägeblattgehäuse Satz	1	310574268	S
	Blade Guard	Carter disque	Sägeblattgehäuse	1		
	Hex screw ISO 4017 - M10 x 25 mm	Vis ISO 4017 - M10 x 25 mm	Schraube ISO 4017 - M10 x 25 mm	1		
	Hex nut ISO 4032 M10	Ecrou ISO 4032 M10	Mutter ISO 4032 M10	1		
	Plain washer ISO 7089 - Ø12 mm	Rondelle ISO 7089 - Ø12 mm	Scheibe ISO 7089 - Ø12 mm	1		
	Torque Nut ISO 7040 M12	Ecrou ISO 7040 M12	Mutter ISO 7040 M12	1		
	Hex screw ISO 4017 - M12 x 80 mm	Vis ISO 4017 - M12 x 80 mm	Schraube ISO 4017 - M12 x 80 mm	1		
26	Black Rubber Carpet Kit	Kit Protection	Spritzschutz Satz	1	310574269	W
	Black Rubber Carpet	Tapis protection	Spritzschutz	1		
	Hex screw ISO 4017 - M10 x 20 mm	Vis ISO 4017 - M10 x 20 mm	Schraube ISO 4017 - M10 x 20 mm	2		
	Plain washer ISO 7089 - Ø10 mm	Rondelle ISO 7089 - Ø10 mm	Scheibe ISO 7089 - Ø10 mm	2		
	Torque Nut ISO 7040 M10	Ecrou ISO 7040 M10	Mutter ISO 7040 M10	2		
27	Water connection Kit	Kit Système d'arrosage	Bewässerungssystem	1	310574270	S
	Water Hose Ø10 mm	Busette d'arrosage Ø10 mm	Wasserschlauch	2		
	Gate valve	Robinet	Wasserhahn	1		
	Geka plug	Plug Geka	GEKA Ventilanschlusstück	1		
28	Water Connector Y Brass	Water Connector Y Brass	Y Ventilanschlusstück	1	310574271	S

Water tank / Réservoir d'eau / Wasserwanne

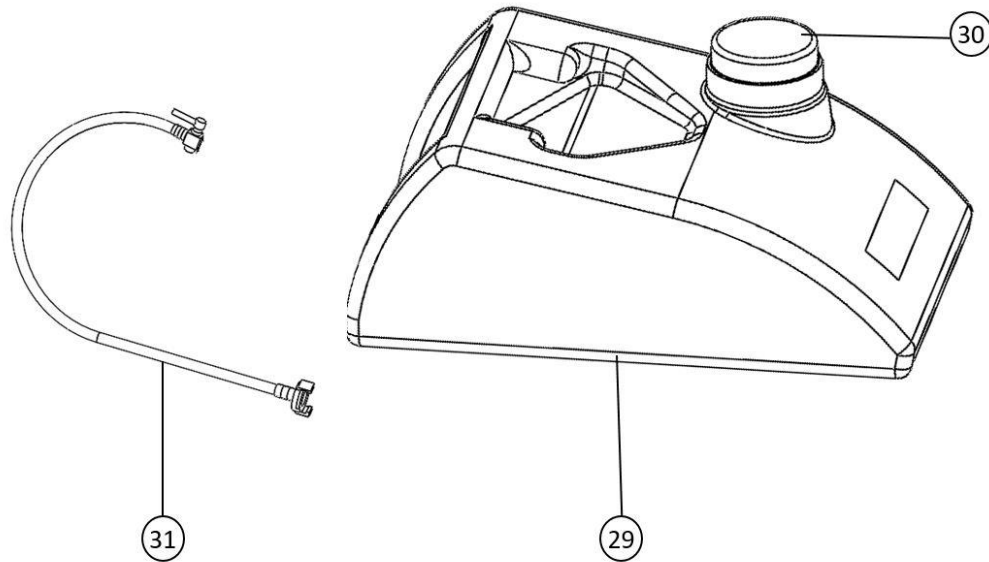

POS.	DESCRIPTION	DESCRIPTION	BESCHREIBUNG	QTY	REF	TYPE
29	Water Tank Kit	Kit réservoir d'eau	Wasserwanne, kompl.	1	310562843	S
	Water tank	Réservoir d'eau	Wasserwanne	1		
	Capuchon	Capuchon	Wasserwanne Stopfen	1		
30	Capuchon	Capuchon	Wasserwanne Stopfen	1	310006560	S
31	Water Tank Connection Kit	Kit connection réservoir d'eau	Wasseranschluss, kompl.	1	310562844	W
	Geka plug	Plug Geka	GEKA Ventilanschlussstück	1		
	Gate valve	Robinet	Wasserhahn	1		
	Water pipe Ø10 mm	Tuyau	Wasserschlauch	1		

Stickers / Autocollants / Aufkleber



POS.	DESCRIPTION	DESCRIPTION	BESCHREIBUNG	QTY	REF	TYPE
32	Sticker kit	Kit d'autocollants	Aufkleber Satz	1	310589602	S
	White arrow	Flèche blanche	Weißer Pfeil	3		
	4 pictograms	4 pictogrammes	4 Piktogramme	1		
	Left side	Flanc gauche	Linke Flanke	1		
	Right side	Flanc droit	Rechte Flanke	1		
	Norton Clipper Logo Blade guard	Norton Clipper carter de disque	Norton Clipper Scheibehäuse	1		
	Risk of hand cut	Risque de coupure main	Gefahr von Schnittverletzungen	1		
	Stop sticker	Sticker CE	CE Aufkleber	1		
	Logo 3 bands	Logo 3 bandes	3 Bänder Logo	1		

Accessoires / Accessories / Zubehör

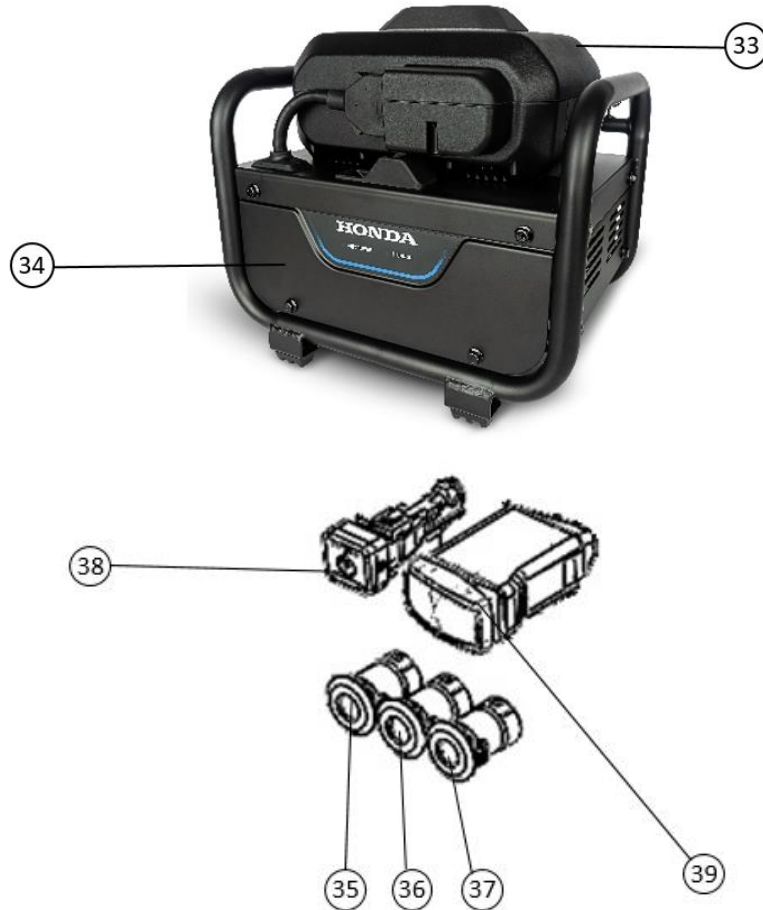

POS.	DESCRIPTION	DESCRIPTION	BESCHREIBUNG	QTY	REF	TYPE
33	Battery DP 72104Z E for GXE	Batterie DP 72104Z E for GXE	Akkupack DP 72104Z E for GXE	1	310568970	S
34	Rapid Charger CV 7285Z EM for GXE	Chargeur rapide CV 7285Z EM for GXE	Akkuladegerät CV 7285Z EM for GXE	1	310568971	S
35	Green led	LED verte	Grün led	1	310589604	S
36	Orange led	LED orange	Orange led	1	310589605	S
37	Red led	LED rouge	Rot led	1	310589606	S
38	POWER button	Bouton POWER	POWER-Taste	1	310589607	S
39	ON/OFF switch	Interrupteur ON-OFF	ON/OFF-Schalter	1	310589608	S

SAINT-GOBAIN ABRASIVES
 INDUSTRIEWEG 21
 9420 ERPE-MERE
 BELGIUM
 TEL: +32(0) 2 267 21 00

SAINT-GOBAIN CONSTRUCTION
 PRODUCTS CZ A.S
 DIVIZE ABRASIVES
 SMRČKOVA 2485/4
 180 00 PRAHA 8
 CZECH REPUBLIC
 TEL: +420 255 719 326
 FAX: +420 255 719 321

SAINT-GOBAIN ABRASIVES A/S
 DYBENDALSVÆNGET 2,
 DK-2630 TAASTRUP
 DENMARK
 TEL: +45 4675 5244

PO BOX 643706
 FORTUNE TOWER OFFICE 2106
 JLT BLOCK C
 (NEXT TO METRO STATION)
 JUMEIRA LAKE TOWER, DUBAI
 UNITED ARAB EMIRATES
 TEL: +971 4 431 5154
 FAX: +971 4 431 5434

SAINT-GOBAIN ABRASIFS
 RUE DE L'AMBASSADEUR - B.P.8
 78 702 CONFLANS CEDEX
 FRANCE
 TEL: +33 (0)1 34 90 40 00
 FAX: +33 (0)1 39 19 89 56

SAINT-GOBAIN ABRASIVES GMBH
 BIRKENSTRASSE 45-49
 D-50389 WESSELING
 GERMANY
 TEL: +49 (0) 2236 703-0
 FAX: +49 (0) 2236 703-730

SAINT-GOBAIN ABRASIVES KFT.
 1225 BUDAPEST
 BÁNYALÉG U. 60/B.
 HUNGARY
 TEL: +36 1 371 22 50
 FAX: +36 1 371 22 55

SAINT-GOBAIN ABRASIVI S.P.A
 VIA PER CESANO BOSCONI 4
 I-20094 CORSICO MILANO
 ITALY
 TEL: +39 02 44 851
 FAX: +39 02 44 78 266

SAINT-GOBAIN ABRASIVES S.A.
 190 RUE J.F. KENNEDY
 L-4930 BASCHARAGE
 GRAND DUCHE DE LUXEMBOURG
 TEL: +352 50 401 1
 FAX: +331 83 717 792
 NO. VERT (FRANCE): 0800 906 903

SAINT-GOBAIN ABRASIFS, S.A.
 2 ALLÉE DES FIGUIERS
 AIN SEBAË - CASABLANCA
 MOROCCO
 TEL: +212 5 22 66 57 31
 FAX: +212 5 22 35 09 65

SAINT-GOBAIN ABRASIVES BV
 GROENLOSEWEG 28
 7151 HW EIBERGEN
 P.O. BOX 10
 7150 AA EIBERGEN
 THE NETHERLANDS
 TEL: +31 545 466466
 FAX: +31 545 474605

SAINT-GOBAIN ABRASIVES AS
 KARIHAUGVEIEN, 89
 0186 OSLO
 NORWAY
 TEL: +47 63 87 06 00
 FAX: +47 63 87 06 01

SAINT-GOBAIN HPM POLSKA SP. Z O.O.
 UL. NORTON 1, 62-600 KOŁO
 62-600 KOŁO
 POLAND
 TEL: +48 63 26 17 100
 FAX: +48 63 27 20 401

SAINT-GOBAIN ABRASIVOS, L. DA
 ZONA INDUSTRIAL DA MAIA
 I-SECTOR VIII, NO. 122
 APARTADO 6050
 4476 - 908 MAIA
 PORTUGAL
 TEL: +351 229 437 940
 FAX: +351 229 437 949

SAINT-GOBAIN GLASS
 BUSINESS UNIT ABRASIVI
 PUNCT DE LUCRU : LOC.VETIS, JUD.
 SATU MARE 447355
 STR. CAREIULUI 11
 PARC INDUSTRIAL RENOVATIO
 ROMANIA
 TEL: +40 261 839 709
 FAX: +40 261 839 710

SG HPM RUS
 58, F. ENGELS STR.
 STROENIE 2
 105082 MOSCOW
 RUSSIA
 TEL: +74 955 408 355
 FAX: +74 959 373 224

SAINT-GOBAIN
 ABRASIVES (PTY) LTD
 2 MONTEER ROAD
 ISANDO 1600
 P.O. BOX 67
 SOUTH AFRICA
 TEL: +27 11 961 2000
 FAX: +27 11 961 2184/5

SAINT-GOBAIN ABRASIVOS, S.A.
 CTRA. DE GUIPÚZCOA, KM. 7,5
 E-31195 BERRIOPLANO (NAVARRA)
 SPAIN
 TEL: +34 948 306 000
 FAX: +34 948 306 042

SAINT GOBAIN ABRASIVES AB
 GÅRDSFOGDEVÄGEN 18A
 168 66 BROMMA • SVERIGE
 SWEDEN
 TEL: +46 8 580 881 00
 FAX: +46 8 580 881 30

SAINT-GOBAIN INOVATIF MALZEMELER
 VE ASINDIRICI SAN. TIC. AS.
 ALTAYÇEŞME MAH. ÇAMLI SOK. NO:21
 ESAS OFISPARK KAT:9 34843
 MALTEPE, İSTANBUL • TURKEY
 TEL: 0090-216-217 12 50
 FAX: 0090-216-442 40 74

SAINT-GOBAIN ABRASIVES LTD.
 UNICORN HOUSE UNIT 1, AMISON CLOSE
 REDHILL BUSINESS PARK
 STAFFORD ST161WB
 UNITED KINGDOM
 TEL: +44 1785 279 553
 FAX: +44 1785 213 487



Saint-Gobain Abrasifs
 190 Rue J.F. Kennedy
 L-4930 Bascharage
 Grand Duche de Luxembourg
 Tel: +352 50 4011
 Fax: +331 83 717 792
 no. vert (France) 0800 906 903