

CP512-300 / CP514-350 CP512-300i / CP514-350i

ORIGINALBETRIEBSANLEITUNG

TRANSLATION OF THE ORIGINAL INSTRUCTIONS

TRADUCTION DE LA NOTICE ORIGINALE

TRADUCCIÓN DEL MANUAL ORIGINAL

VERTALING VAN DE OORSPRONKELIJKE GEBRUIKSAANWIJZING

ПЕРЕВОД ОРИГИНАЛЬНОГО РУКОВОДСТВА ПО ЭКСПЛУАТАЦИИ



CE

de

en

fr

es

nl

ru



NORTON
SAINT-GOBAIN®

clipper®

Instruction manual cut-off machines CP512-300 / CP514-350 // CP512-300i / CP514-350i

Translation of the original instructions

Dear customer,

Thank you for purchasing this quality product from our company.

For many decades, we have been a producer of hand-held and back-carried gas powered motor devices. Each of our motor devices benefits from this experience in detail today as well.

State-of-the-art production materials in connection with our know-how warrant a long service life and high utilisation value of the motor device.

The motor devices of this model line are particularly high-quality cut-off machines of German production and designed specifically for the high demands of professional users. A newly developed single-cylinder two-stroke high-performance engine with stationary nikasil-coated cylinder in proven four-channel technology for great performance at low fuel consumption and the latest exhaust cleaning technology warrant high utilisation value of the motor-driven device.

Maintenance-free electronic ignition, health-protecting anti-vibration system, patented twin-pipe suction procedure, vibration system for particularly easy interim emptying of the air filter during work, optionally usable water connection with water supply to the cut-off wheel to reduce dust when working, smart solutions with electronic carburettor control for simple starting and ergonomic design and extremely compact build ensure excellent operating comfort and facilitate daily work with the motor device.

The safety equipment corresponds to the latest state of the art and meets all nationally and internationally relevant safety provisions. Among others, it comprises:

- One-touch stop button
- Throttle control lock
- Electronic speed limiter
- Wheel guard for the cut-off wheel
- Motor stop facility for maintenance purposes



Before first using this tool, read these operating instructions thoroughly and always observe all safety provisions and instructions.

If you have any further questions after reading these operating instructions, contact your specialist vendor.



Observe the maintenance guidelines closely to ensure the long service life of your equipment

Packaging and disposal

Please keep the original packaging in order to protect the equipment against transport damage in case you ever need to ship or transport it. If the packaging materials are no longer required they must be disposed of properly in accordance with applicable local regulations. Cardboard packaging materials are raw materials which can be recycled or reused.

At the end of the equipment's service life, please make sure that you dispose of it in accordance with the local provisions.

Patents

The following patents have been granted:

- PCT/EP2011067574 (separate lubrication)
- US20120152200 (airbox)
- US20100206278
- US20100000846
- US20090007435
- EP2011594
- EP2011991
- EP2011992

Registered brands and trademarks

Norton Clipper[®] is a registered brand of Saint-Gobain Abrasives.

Any other product and company names named in these operating instructions may be registered brands or trademarks of the respective manufacturer. Use of these names by third parties for their purposes may injure the rights of the manufacturer. The fact that the ® or ™ sign is missing does not mean that the designation is a free brand name.

Reservation of changes

In the interest of continuous further development of the motor devices, the manufacturer must reserve changes to the delivery scope in form, technology and equipment.

Please understand that no claims can be derived from information and illustrations in these instructions.

Table of Contents

1	Information about these operating instructions	4
1.1	<i>Notational conventions used in the operating instructions</i>	4
2	Warning, instruction and notice icons	4
3	Safety provisions	6
3.1	<i>Correct use</i>	6
3.2	<i>General safety notes</i>	6
3.3	<i>Personal Protection Equipment (PPE)</i>	7
3.4	<i>When fuelling up</i>	8
3.5	<i>In transport</i>	8
3.6	<i>During assembly, cleaning, maintenance and repair</i>	9
3.7	<i>Before start-up</i>	9
3.8	<i>When starting</i>	9
3.9	<i>During work</i>	10
3.10	<i>Dust emission</i>	11
4	Power tool description	11
4.1	<i>Scope of delivery</i>	11
4.2	<i>Type plate</i>	11
4.3	<i>Device views and important operating and function parts</i>	12
4.4	<i>Throttle control lock and throttle control</i>	14
4.5	<i>Function parts for starting</i>	14
4.6	<i>Technical data</i>	15
5	Preparing for use	16
5.1	<i>Installing the cut-off wheel</i>	16
5.2	<i>Installing cut-off wheels with 1" inner bore</i>	17
5.3	<i>Removing the cut-off wheel</i>	17
5.4	<i>Adjusting wheel guard</i>	18
5.5	<i>Fuelling up</i>	18
5.6	<i>Adjusting the ribbed belt tension</i>	20
5.7	<i>Water connection for wet cutting</i>	20
5.8	<i>Relocate cutting device from centre position to outer position</i>	21
5.9	<i>Initial starting / run-in behaviour</i>	23
6	Starting up and switching off the engine	24
6.1	<i>Starting process</i>	24
6.2	<i>Start-up position</i>	25
6.3	<i>Switching on the engine</i>	25
6.4	<i>Switching off the engine</i>	25
7	Power tool use	26
7.1	<i>Cut-off wheels</i>	26
7.2	<i>Permissible cutting area and danger from kickback or pinching</i>	27
7.3	<i>Working behaviour and working technique</i>	28
7.4	<i>Cutting metal</i>	28
7.5	<i>Cutting mineral materials</i>	29
8	Operating and maintenance notes	30
8.1	<i>Cleaning and care</i>	30
8.2	<i>Cleaning the screen filter insert of the connection piece</i>	31
8.3	<i>Idle/carburettor adjustment</i>	32
8.4	<i>Air filter maintenance</i>	33
8.5	<i>Spark plugs check and replacement if required</i>	34
8.6	<i>Ribbed belt replacement</i>	35
8.7	<i>Fuel filter replacement</i>	36
8.8	<i>Maintenance plan</i>	37
8.9	<i>Self-aid advice</i>	38
8.10	<i>Shutting down and storage</i>	39
9	Warranty	40
10	Wear parts	40
11	EC Declaration of conformity	40

1 Information about these operating instructions

These operating instructions are an integral part of the motor device.

 They contain important information and instructions for handling the motor device. Always follow any specified safety regulations and instructions, as they are a prerequisite for ensuring that you are working safely with the equipment.

 These operating instructions must be kept available at the place of use of the equipment at all times, and they must be read carefully by everyone who works on or with the equipment (including for maintenance, care and repairs).

These operating instructions must only be used as operating instructions for the motor device CP512-300 / CP514-350 // CP512-300i / CP514-350i.

Any utilisation of the contents (text and graphics illustrations) – even in excerpts – without the manufacturer's prior written consent shall be forbidden and may be prosecuted.

1.1 Notational conventions used in the operating instructions

Text highlights

Xxxxx Underlined text marks interim headlines.

Xxxxx Text in italics marks advice and notes that facilitate use of the motor device for the user.

1 Xxxxx Numbered text with a black background marks main chapter headlines.

1.1 Xxxx Numbered text with a grey background marks main subchapter headlines.

Xxxxxxx Frames mark especially highlighted sections.

Structure

The operating instructions are structured by numbered main and subchapters. The table of contents on page 3 shows an overview of the structure.

Header

To make it easier for the user to find the chapters, the header names the main chapter to which the content on the respective page belongs.

Pictures and diagrams

Some graphical illustrations in these operating instructions are schematic illustrations or principle illustrations and may not show exactly your device model. The conveyed contents, however, are binding in any case.

2 Warning, instruction and notice icons

Important: If one or several icons in these operating instructions are centred and directly below a chapter header the notice applies for the entire chapter.

Warning, instruction and notice icons used in the operating instructions and on the equipment:

Warning! Failure to comply with the instructions could cause accidents with potentially life-threatening injuries.



Caution! Failure to comply with the instructions could result in damage to the equipment or other material damage.



Carefully read the operating instructions. This applies before placing the equipment into operation and before any cleaning, maintenance or assembly work.



Always wear the prescribed clothing. → Chap. 3.3, page 7



Always wear sturdy shoes with good grip.



Wear safety gloves. This applies to all work with or on the equipment.



Before starting the engine, put on hard hat, hearing protection, face shield and safety glasses.



Switch off the engine!



Smoking is prohibited anywhere near the power tool and in the location where it is refuelled!



Keep the power tool and fuel canisters away from open flames.



Warning: Danger of poisoning! - The power tool generates exhaust gases.
- Gasoline vapours are toxic.
- Dangerous dust emissions when working.



Warning: Kickback!
Notes in chap. 7.2 as of page 27 must be observed under all circumstances!



Warning: Danger of fire from sparks.



Wear breathing protection equipment.



Never use toothed circular saw blades.



Never use a damaged cut-off wheel.



Only use cut-off wheels approved for a speed of $\geq 4,450 \text{ min}^{-1}$ [4,450 rpm].



Vibrator dial for interim emptying of the air filter → Chap. 8.4, page 33



Noise level $L_{WA} = 110 \text{ dB(A)}$



iLube® = Smart lubrication (separate lubrication, only for model CP512-300i and CP514-350i)



Fuel tank → Chap. 5.5, as of page 18



Oil tank (green cap, model CP512-300i and CP514-350i) → Chap. 5.5, as of page 18

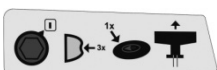

Starting notes → Chap. 6, as of page 24

3 Safety provisions

3.1 Correct use



This power tool must only be used to cut/shorten metals (hot cut) and mineral materials, such as concrete (cold cutting). Use only the cut-off wheels approved for the material being cut and only for the working situation indicated in chap. 7 on page 26.

For specifically trained users in rescue missions, other approved cut-off wheels are also offered that can be used to cut various composites. These special applications are only permitted to specifically trained users.

This power tool must only be used for outdoor work.

Use of this power tool for any other purpose, such as sawing of wood and to remove/grind off a material using the side surfaces of the cut-off wheel is forbidden.

Unapproved cutting tools, such as saw blades or knives, must never be installed on the motor device.

3.2 General safety notes



Before using, read these operating instructions thoroughly and keep them in a safe and accessible location. They must be kept available at the place of use of the equipment at all times, and they must be read by everyone who works on or with the equipment (including for maintenance, care and repairs).

Use this power tool with care. Improper or careless use of this power tool could cause serious injury or death. The tool can generate large forces and torques resulting from the high speed rotation of the cut-off wheel.

Working with and on the power tool must be done carefully and with the greatest care. Thorough risk estimation must be performed before taking up the work. Never perform any work processes that you are not ready for or the risks of which you cannot entirely assess. If you are still unsure after studying these operating instructions, ask a specialist for help.

The ignition unit of this power tool generates an electromagnetic field in operation. This field may affect the function of pacemakers under certain conditions. Persons with a pacemaker must consult their physician and the pacemaker manufacturer before using this power tool.

General information on vibration: The following symptoms may occur from frequent vibration of fingers, hands or wrists: Fingers, hands or wrists falling asleep, tickling, pain, stabbing pain, changes of the skin tone or skin. If such symptoms are found, see a physician.

Failure to observe the safety notes may be potentially fatal. Observe the accident prevention provisions of the local committees, authorities and the professional associations.

- For any accidents that may occur, a first aid kit must be present at the workplace at all times. Material that has been removed must be refilled at once.
- Danger of fire from sparks! When working close to easily flammable objects or vegetation, a fire extinguisher must be provided.
- A first time operator should obtain practical instruction by a specialist before using the power tool.
- Children and teens (minors) under 18 years of age must not work with this power tool; this does not include youths older than 16 who are trained under supervision.
- The power tool generally must be operated by only one person – also when starting up. Keep unnecessary personnel away from the work area. Do not work around animals. If a person or animal approaches, the power tool must be stopped at once. The user is responsible for any injury and property damage he causes.
- This power tool must only be used by persons who are familiar with this type of machine, its operation and the operating instructions. Never lend this power tool to personnel not familiar with this power tool. Always include these operating instructions.
- Only work with this power tool when you are in good shape, rested and healthy.

- Persons under the influence of alcohol or drugs, including prescription drugs, should never use this power tool, as their ability to quickly react to potential danger may be impaired.
- Never operate this power tool when you are fatigued or exhausted. Tiredness and exhaustion may result in loss of control. Be alert – if you get tired or exhausted while operating your power tool, take a break. Working with the power tool can be strenuous. If you have any condition that might be aggravated by strenuous work, check with your doctor before operating this power tool.
- If materials that may contain asbestos or other toxic substances are to be cut, inform the relevant authority first. Work must only be performed upon approval and only under supervision and compliance with the required safety measures.
- Be aware of hidden hazards, such as electrical cables, water or gas pipes and flammable substances in the area to be cut!
- When cutting pre-tensioned and steel-reinforced concrete pillars, observe all instructions and standards that the respective authorities or component manufacturers have stipulated. Cutting of reinforcement bars must be performed in the prescribed order and under consideration of the relevant safety provisions.
- Never alter, change or modify any safety equipment or functional assemblies of this power tool.
- Prevent accidents! Only use this power tool if it is in good, safe condition! Always check the power tool prior to use.
- Only use those accessories and attachments that have been supplied and approved for attachment to this power tool by the manufacturer.
Only cut-off wheels approved for this power tool must be used as cutting tools.
- Reliable operation and safety of this power tool also depend on the quality of the spare parts used. Use only genuine spare parts. Original spare parts are identical with original production parts and guarantee the best quality in material, dimensions, function and safety. Original parts and accessories are available from your specialist dealer. Your dealer has been supplied with appropriate documentation to determine the correct parts. Your dealer is frequently supplied with updates about improvements to the equipment. Please note that the use of non-original parts will void your warranty.
- Always store the power tool in a safe place and in such a way that it will not pose any danger. Stop the engine. Never let the power tool run unsupervised!

Persons who disregard safety instructions, operating or maintenance instructions are liable for any damage or consequential losses.

3.3 Personal Protection Equipment (PPE)



In order to prevent injuries, please make sure that you wear the prescribed clothing and protective equipment.



Clothes should be tight-fitting (no lapels), but not hindering. When performing any work, wear a working suit of firm materials with sufficient flame inhibition that cannot ignite by flying sparks (materials of leather, cotton after flame-inhibiting treatment or heavy close-meshed linen fabrics).

Check the information in the work clothes and ensure that non-flammable materials and no synthetic materials like polyester or nylon are contained in the clothes. The working clothes must never be contaminated with flammable substances such as gasoline or similar products.

Do not wear scarves, ties, jewelry or other clothes that may get caught in the cut-off wheel, objects in the environment, or the power tool. Tie back long hair and secure it under a hard hat.



Wear a protective hard hat during any work. Use personal hearing protection. Eye and face protection is mandatory pursuant to ANSI Z 87.1.



Wear firm safety shoes with steel toes and a good grip.

Wear a protective apron.



Wear protective gloves with non-slip palms.



When wet cutting is not utilized, the operator and bystanders should always wear adequate breathing protection equipment

3.4 When fuelling up



Gasoline is highly flammable. Keep away from open flame and do not spill fuel. Do not smoke at the workplace or at the site of fuelling!

- Always switch off the engine before fuelling.
- Fire hazard! Never refuel while the engine is still hot!
- Always carefully open the tank cap so that any overpressure present can reduce slowly and no fuel will splash out.
- Prevent skin and eye contact with fuel and other mineral oil products by wearing protective clothing, eye and face protection. In case of eye contact, rinse at once with lots of clear water. In case of persistent irritation, see a doctor immediately!
- Regularly change and clean protective clothes.
- Avoid breathing in fuel vapour.
- The refuelling site should be well ventilated.
- Avoid any soil spillage of fuel or oil (protection of the environment). Use a suitable mat.
- Immediately clean any fuel spilled on the power tool. Change contaminated clothing without delay.
- Always tighten the fuel tank cap firmly by hand without using any tools. Tank caps are equipped with an overturning protection and must be turned closed until a clear "skipping".
The fuel tank cap must not be able to work itself loose as a result of the vibrations of the engine.
- Danger to life from burns! Observe leaks. Do not start up and work when fuel is escaping.
- Fuels and oil must only be stored in properly and correctly labeled containers.

3.5 In transport



- Before carrying the power tool (even across short distances from one working area to the next), always turn off the engine and wait until the cut-off wheel has stopped. Carry the power tool by the top handle and have the cut-off wheel point backwards.
- Danger of burns! Do not touch the hot muffler.
- Never carry or transport the power tool with the cut-off wheel running.
- To avoid spilling of fuel and oil and to prevent damage, the power tool must be secured against tipping when transporting it in vehicles. Check the tanks for fuel and oil for tightness.
Recommendation: Empty the tanks before transport.
- Empty the tanks before shipping.
- Remove cut-off wheel before shipping.

Recommendation: Keep the original packaging in order to protect the equipment against transport damage in case you ever need to ship it or transport it.

3.6 During assembly, cleaning, maintenance and repair



- The power tool must not be assembled, maintained, repaired or stored in the vicinity of open flames.
- Before assembly, cleaning, maintenance and repair, always turn off the engine; the stop dial must be set to "0" and the cut-off wheel must have stopped.
Only the idle speed setting must be performed with the engine running.
- Wear protective gloves for any work.
- The power tool requires regular maintenance. Only perform such maintenance and repair work on your own that are described in these operating instructions and that you consider yourself skilled at performing. Any other work must only be performed by specialist workshops authorised by the manufacturer.
- Danger of burns! Do not touch the muffler while it is still hot – not even for maintenance or to check it for tight fit.
- Only perform repairs with original spare parts.
- Danger of accident and injury! Never modify the power tool, as this may impair safety!

3.7 Before start-up



Before start-up, check the entire power tool for operationally safe conditions. In addition to the notes in the operating and maintenance notes (→ chap. 8, page 30), check the following items:

- Stop dial and one-touch stop button must be easy to operate.
- The throttle control must move freely and return automatically to the idle position. It must not be possible to operate the throttle control without pushing (unlocking) the throttle control lock (throttle control locked).
- The cut-off wheel must be attached firmly to the spindle.
- Danger of fire! Ignition cable and spark plug connector must be firmly in place. Loose connection can result in sparks which could ignite any escaping fuel/air mixture!
- In case of irregularities, visible damage, improper settings or limited function, the power tool must not be started. In such cases, have the power tool inspected by specialist workshops authorised by the manufacturer.

3.8 When starting



- Only use the power tool if it is in completely assembled condition.
- Keep at least 3 metres [approx. 10 feet] distance from the fuelling site when starting.
Never start the power tool in closed rooms.
- Hold the tool securely and firmly when starting.
Always start up on level ground and securely hold the power tool.



Perform the starting process as described in chap. 6 on page 24.

- Check the idle setting after starting. The cut-off wheel must not rotate in idle mode.

3.9 During work



In addition to the safety provisions already listed, the following safety provisions also apply when working with the motor device:

- Danger of poisoning! Once the engine is running, the power tool produces toxic exhaust that may be invisible and odourless. Never start the power tool in closed rooms. Special danger also applies in narrow situations, troughs or ditches. Only work here when it is absolutely certain that there is sufficient air exchange and that no toxic gases may accumulate.
- Increased danger of fire! Do not smoke at the workplace – not even in the proximity of the power tool.
- Secure the workplace against accidental access by third parties, e.g. with warning signs. Only persons involved and wearing adequate protective equipment and clothes must be present within 30 metres [approx. 30 yards] around the working area.
- Check the site of deployment for possible dangers.
 - Spark formation during cutting means that work must never be performed close to potentially explosive gases of liquids, or easily flammable objects.
 - No electrical lines, water or gas pipes or flammable substances must be placed in the area to be cut.
 - Objects that may fall off or topple over during work must be secured or removed from the working environment first.
 - Prepare the workplace so that secure operator mobility is possible.
- The work piece to be cut must be free of foreign bodies such as screws, nails or stones.
- When working in residential areas, observe the noise protection provisions.
- Work carefully, considerately and calmly and do not endanger others.
 - Ensure good sight and light conditions.
 - Always remain within calling distance of other persons who may administer first aid in emergencies.
 - Schedule work breaks.
 - Be attentive towards possible danger sources and take the corresponding preventive measures. Consider that use of hearing protection limits perception of sounds. Signal sounds, calls, etc. that announce danger may also be missed.
 - Observe tripping dangers and obstacles. Never work on unstable grounds.
 - Always hold the power tool with both hands and always ensure a safe and firm stance.
 - Never cut standing on a ladder.
 - Guide the power tool so that no body part is located in the extended swivel range of the cut-off wheel.
 - Do not hold the work piece in your hand and bring it into contact with the wheel.
 - Process only the work piece to be cut with the rotating cut-off wheel. Never touch the floor or other objects with the cut-off wheel running.
 - Do not use the power tool to level off and shovel away objects.
- Switch off the engine when the power tool starts to behave noticeably differently.
- Danger of burns! Do not touch the muffler while it is still hot.
Danger of fire! Muffler radiates enormous heat.
Never put the hot power tool into dry grass or on flammable objects.
- Danger of hearing damage and burns!
Never work with defective muffler or without muffler.

3.10 Dust emission



If metals or mineral materials, such as stone, masonry, concrete or ceramics are processed with the power tool, fine dust, dust, steam and smoke that contains substances hazardous to health may arise. These substances may cause severe or fatal diseases, such as respiratory diseases, cancer, damage to the reproductive system and genetic code (malformation of progeny).

For example, crystalline silicone dioxide can be released when processing quartz-containing materials such as stone, masonry, granite or concrete. Respirable crystalline silicone dioxide may trigger severe or fatal respiratory diseases, such as silicose, and is suspected of being carcinogenic.

A list of substances hazardous to health might possibly be available from the country-specific authorities, institutes or professional associations.

- If you cannot assess the risk connected with use and setup of the power tool and the material processed, read up the following documents on the health and safety risks:
 - Material-specific safety data-sheets
 - Operating instructions of the power tool
 - Work instructions and safety provisions of your employer
 - Information and recommendations of your dealer, specialist dealer or specialist workshop
 - Information of the country-specific authorities, institutes and professional associations
- Always observe all the work instructions, safety notes and safety provisions for the secure and effective handling of the cutting materials and the power tool that have been published by your employer, country-specific authorities, institutes and professional associations.
- If possible avoid the generation of fine dust, dust, steam and smoke by the corresponding work conduct and work techniques.
- If possible, use cut-off wheels suitable for wet cutting and the water connection of the power tool. When cutting with water supply, the dust is reduced, visibility is improved and the cut-off wheel service life is increased by the cooling effect of the water.
- If danger from inhalation of fine dust, dust, steam and smoke cannot be excluded by technical measures, such as use of the power tool's water connection or a suitable extraction device, all persons in the proximity and users of the power tool must wear suitable breathing protection equipment to protect them from dust.

4 Power tool description

4.1 Scope of delivery

- Basic device
- Cut-off wheel
- Spindle adapter disk for cut-off wheels with 1" inner bore
- Tools: Combination tool (spark plug spanner with screwdriver), blocking pin and additional small screwdriver
- These operating instructions (incl. EC Declaration of conformity: → Chap. 11, page 40)

4.2 Type plate

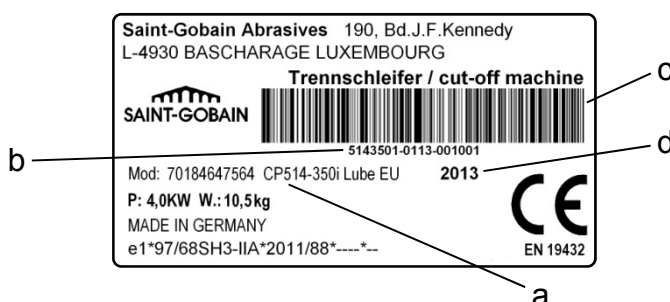

- a: Type designation
- b: Serial number
- c: Bar code
- d: Year of build

4.3 Device views and important operating and function parts

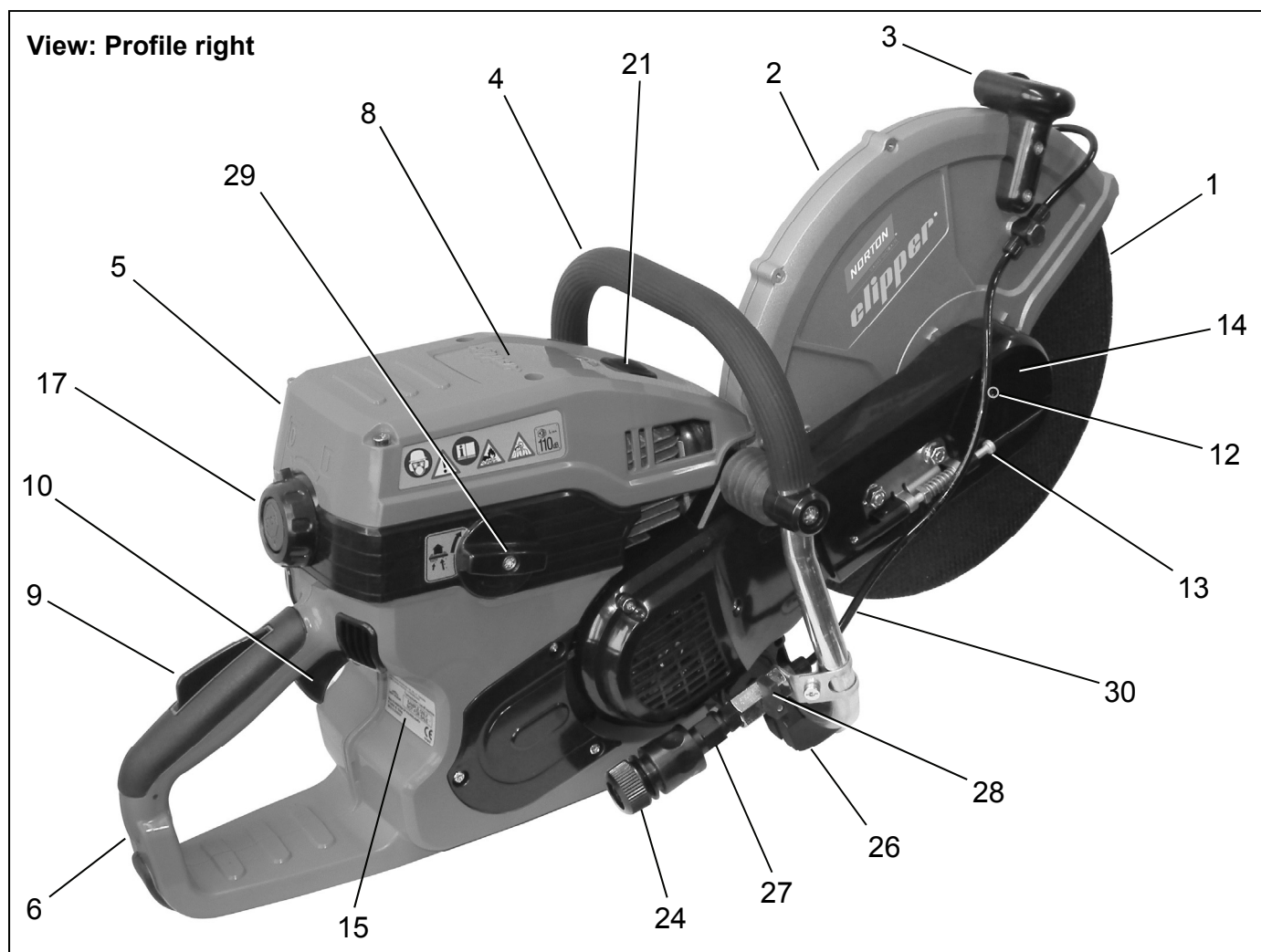

1. Cut-off wheel	16. Starter handle
2. Wheel guard	17. Stop dial / one-touch stop button
3. Handle for wheel guard adjustment	18. Fuel tank cap
4. Top handle	19*. Oil tank cap, green (only for CP512-300i and CP514-350i)
5. Guard	20. Primer
6. Rear handle	21. Decompression valve
7. Twin-pipe intake openings	22. Idle stop screw "T"
8. Spark plug cover	23. Carburettor adjustment screws "L" and "H" (for specialist workshops only)
9. Throttle control lock	24. Water coupling connection (wet cutting)
10. Throttle control	25. Muffler (exhaust)
11. Cut-off wheel attachment screw	26. Standing base
12. Cut-off wheel blockage opening	27. Screen filter coupling adapter of the water supply line
13. Ribbed belt tensioning screw	28. Valve lever for water supply
14. Ribbed belt cover	29. Vibration dial
15. Type plate	30. Water supply line (wet cutting)
	31. Starter and fan housing with cooling air openings

* model-dependent

View: Profile left

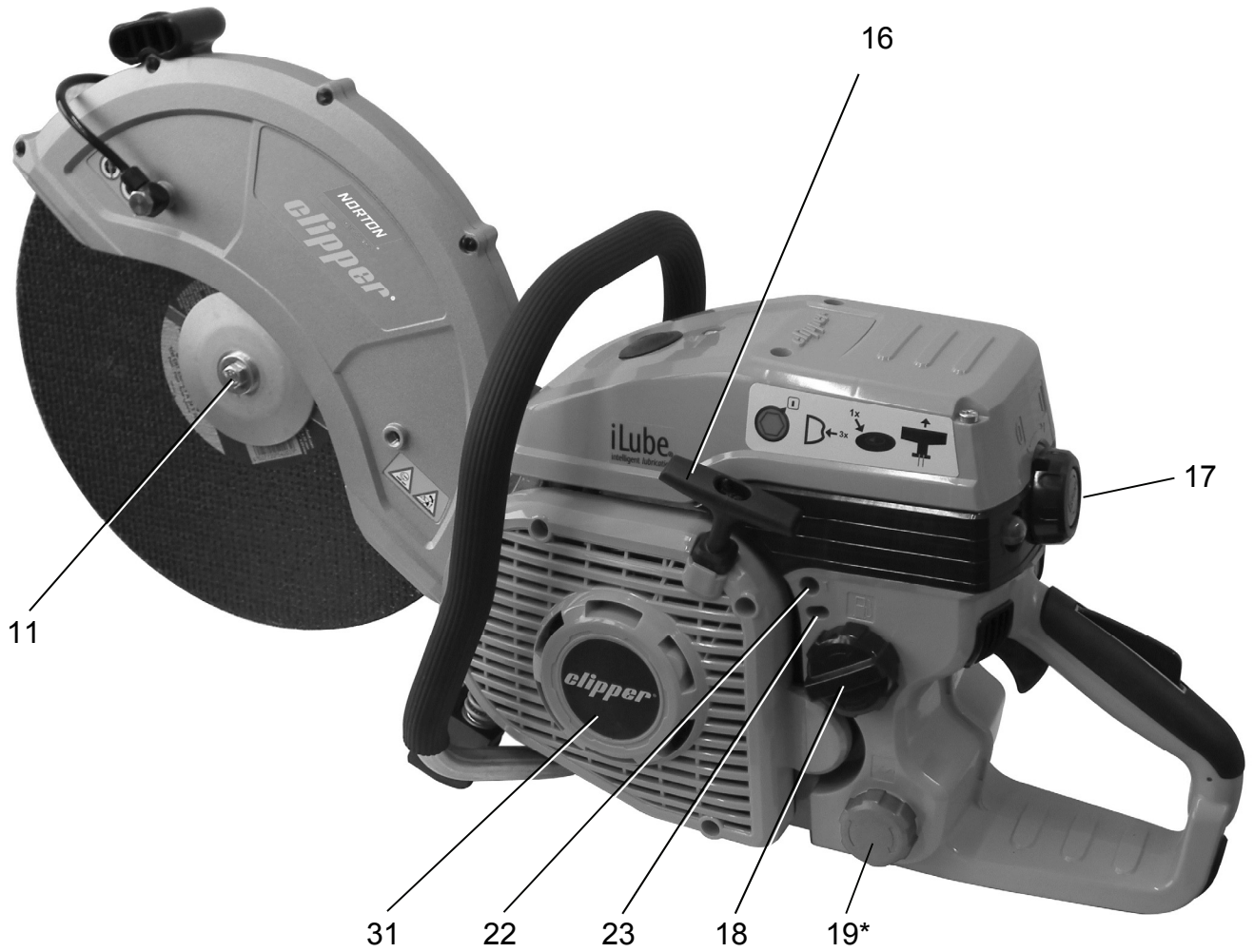

View: Front left

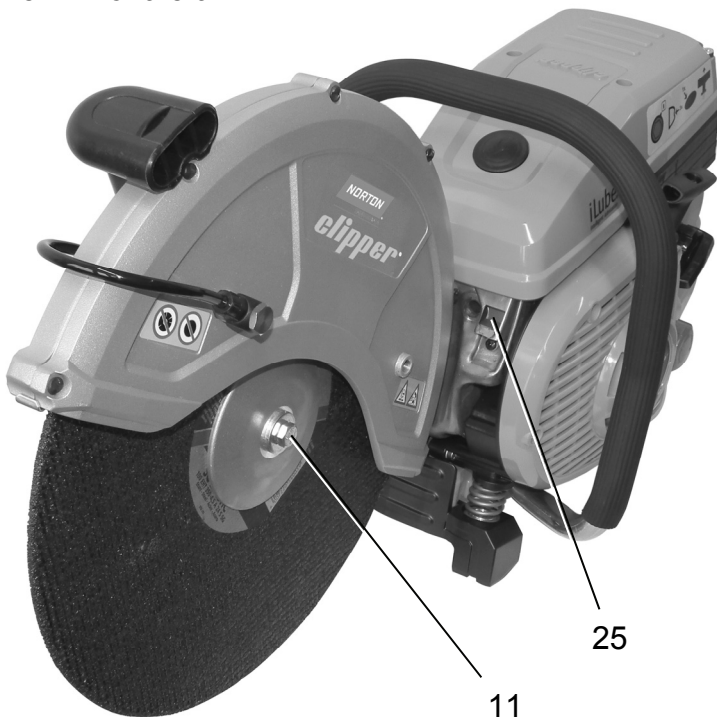

View: Rear

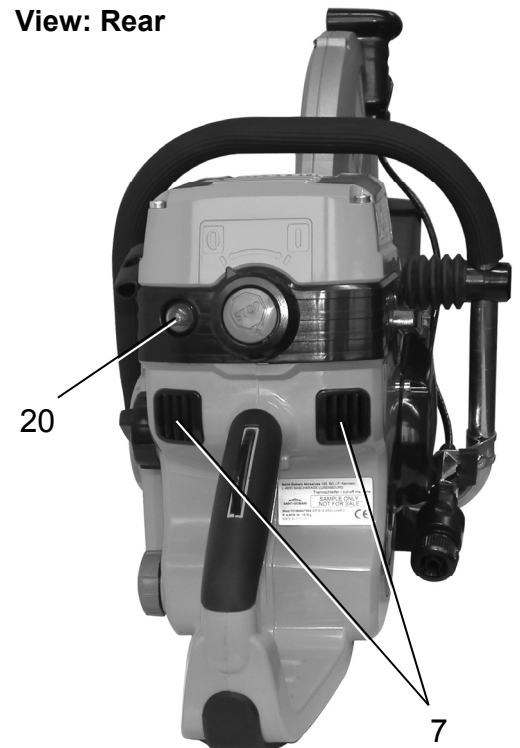

4.4 Throttle control lock and throttle control

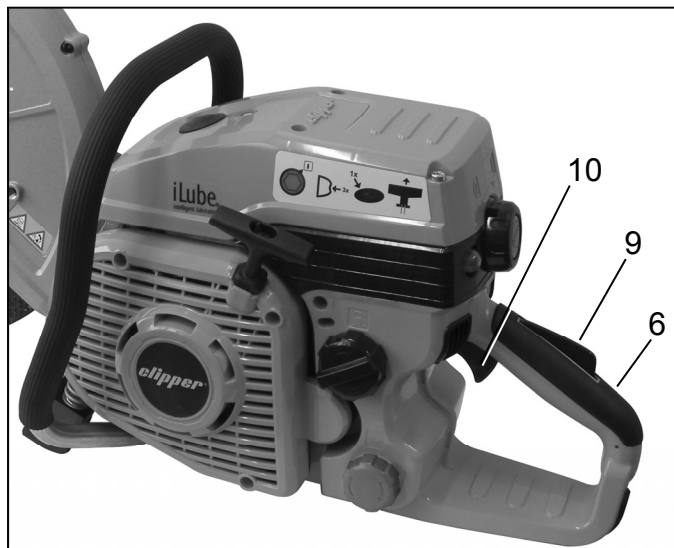

Release of the throttle control (10)

- Grasp rear handle (6) with the right hand. The throttle control lock (9) is operated with the palm.
→ The throttle control (10) is released.

4.5 Function parts for starting

Starter handle (16) and starter rope; → Chap. 6.3, page 25

Primer (20)



In the delivery condition, after extended resting time and with the tank completely empty, there is no fuel yet in the carburettor after fuelling up.

Starting process: → Chap. 6.1, page 24

To facilitate the starting process, fuel can be pumped into the carburettor. Push the primer (20) repeatedly until fuel appears in the primer.

Excess fuel is automatically flushed back into the tank from the primer.

Decompression valve (21)

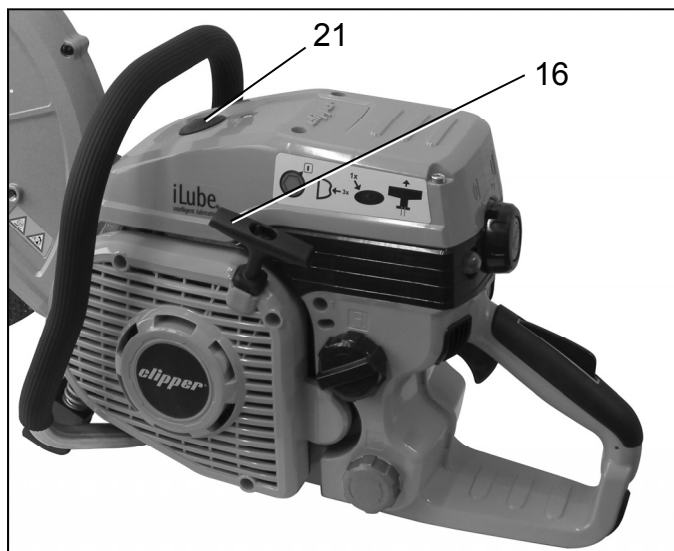

When the decompression valve (21) is depressed, the compression pressure in the combustion chamber is reduced. This means that the engine offers less resistance during start-up, which makes it noticeably easier to start the engine.

Starting process: → Chap. 6.1, page 24

The decompression valve is closed automatically when the motor is running.

If you need to pull the starter handle (16) more than once to start the engine (e.g. during a cold start), you do not need to depress the decompression valve again.

4.6 Technical data

Model	CP512-300	CP512-300i	CP514-350	CP514-350i
Motor	Single-cylinder two-stroke motor, four-channel flushing			
Engine capacity	81 cm ³ [4.94 cu.in]			
Bore Ø / stroke	52 mm / 38 mm [2.0" / 1.5"]			
Max. power at rpm	4.0 kW / 9,300 ¹ / _{min} [5.36 HP / 9,300 rpm]			
Max. torque at rpm	4.8 Nm / 7,000 ¹ / _{min} [3.54 ft·lbf / 7,000 rpm]			
Max. permissible speed	(9,500 ±200) ¹ / _{min} [(9,500 ±200) rpm] (no load with cut-off wheel)			
Idling speed	(2,600 ±200) ¹ / _{min} [(2,600 ±200) rpm]			
Clutch engagement speed	(4,000 ±200) ¹ / _{min} [(4,000 ±200) rpm]			
Fuel tank capacity	0.9 l [30 oz]			
Oil tank capacity	---	0.32 l [10.8 oz]	---	0.32 l [10.8 oz]
Fuel mix ratio oil:gasoline	1:50	---	1:50	---
Electronically controlled separate lubrication	---	✓	---	✓
Fuel consumption at max. power (ISO 7293)	1.75 kg/h [3.86 lbs/h]			
Specific consumption at max. power (ISO 7293)	460 g/kWh [0.76 lbs/HP·h]			
Carburettor, with primer	Position-independent, electronically controlled			
Air filter	Paper			
Ignition	Electronic digital ignition with index			
Cut-off wheel: Diameter Bore diameter Tightening torque of the attachment screw	12" [305 mm] 20 mm or 1" (30 ±2) Nm [22.1 ±1.48 ft·lbf]		14" [356 mm] 20 mm or 1" (30 ±2) Nm [22.1 ±1.48 ft·lbf]	
Minimum flange outer diameter	100 mm [3.9"]		100 mm [3.9"]	
Spindle diameter	20 mm [0.787"]		20 mm [0.787"]	
Maximum spindle rpm	4,450 ¹ / _{min} [4,450 rpm]		4,450 ¹ / _{min} [4,450 rpm]	
Cutting depth, max.	100 mm [3.9"]		125 mm [4.9"]	
Dimensions: height / width / length	430 mm / 267 mm / 750 mm [16.9" / 10.5" / 29.5"]		430 mm / 267 mm / 775 mm [16.9" / 10.5" / 30.5"]	
Weight without tank content and without cut-off wheel	10.1 kg [22.3 lbs]	10.4 kg [22.9 lbs]	10.2 kg [22.5 lbs]	10.5 kg [23.1 lbs]
Sound level ^{1,2} L _{Peq} (EN ISO 19432 Annex B)	98 dB(A)			
Sound power level ^{1,2} L _{W_{eq}} (EN ISO 19432 Annex B)	108 dB(A)			
Weighted effective acceleration ^{1,3} a _{hv,eq} (EN ISO 19432 Annex C): rear handle / top handle	4.5 m/s ² / 6.0 m/s ² [177 "/s ² / 236 "/s ²]			

¹ In determining the following values regarding the acceleration of vibrations and sound, the different operating conditions were weighted in accordance with the current standards.

² Insecurity K purs. to EC directive 2006/42/EC: 2.5 dB(A)

³ Insecurity K purs. to EC directive 2006/42/EC: 2 m/s² [78.7 "/s²]

5 Preparing for use



5.1 Installing the cut-off wheel

- !** The cut-off wheels used must correspond to the specifications from chap. 7.1 on page 26!
 The power tool spindle is designed for cut-off wheels with an inner bore of 20 mm.
 Cut-off wheels with 1" inner bores must only be installed together with the spindle adapter disk.
 Installation of cut-off wheels with 1" inner bore: → Chap. 5.2, page 17!
 When using cut-off wheels with an inner bore of 20 mm, no additional spindle adapter disk is required.

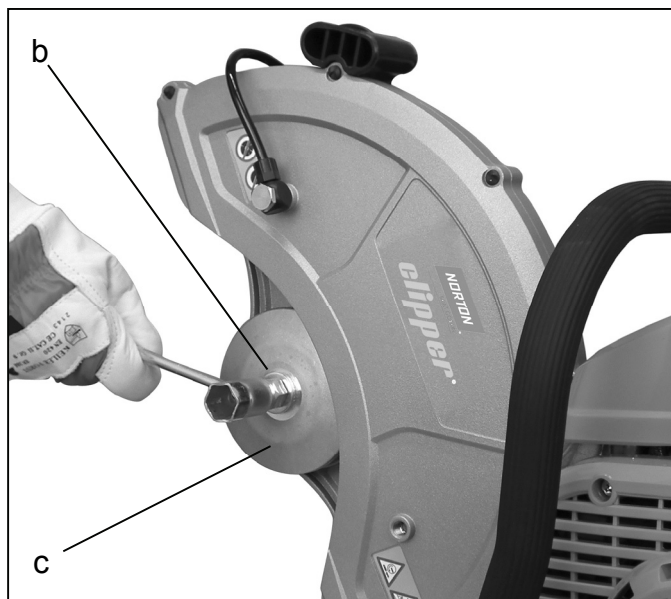
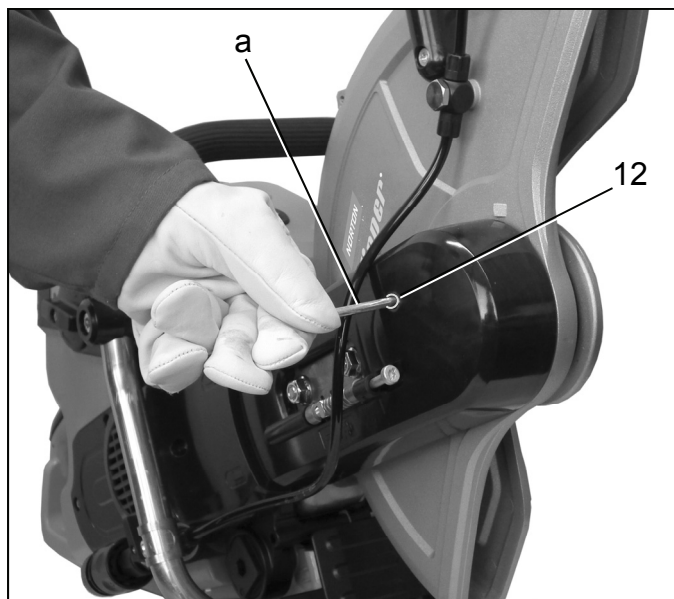

- For cut-off wheel installation, the power tool must be put securely on the ground. Securely hold the power tool at the top handle with the left hand and push it firmly onto the ground. → Chap. 5.4, page 18
- Insert blocking pin (a) entirely into the cut-off wheel blocking opening (12) to block the spindle. Unscrew cut-off wheel attachment screw (11). Remove wheel (b) and outer mounting flange (c).

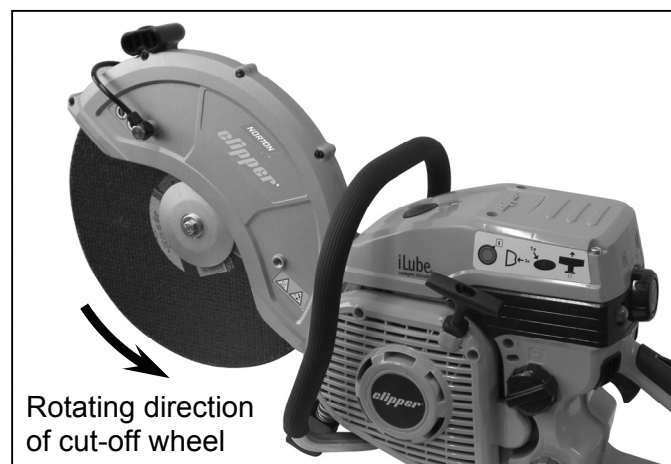
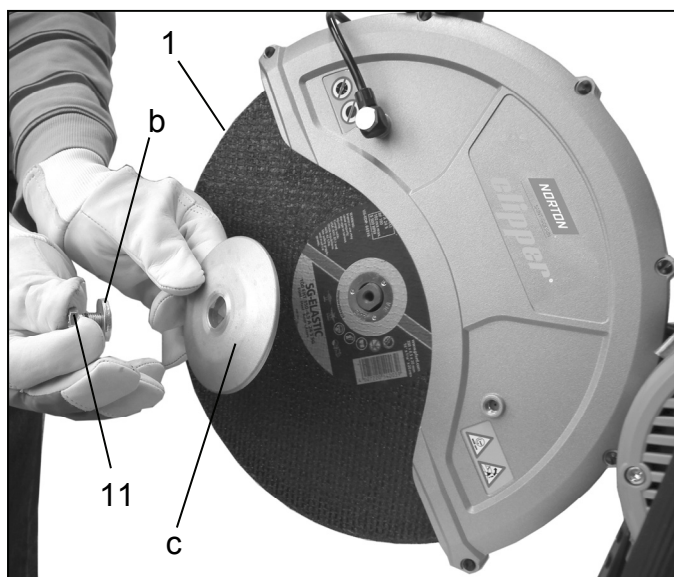

The rotating direction of the cut-off wheel is always as indicated by the arrow above – independently of whether the cutting device is installed in the centre or outer position.

- Put cut-off wheel (1) on spindle.
 For cut-off wheels with specified rotating direction (arrow on the cut-off wheel), observe correct alignment of the cut-off wheel during assembly (for rotation direction of the cut-off wheel, see above).

- Push on outer mounting flange (c) so that the curved side points southwards, i.e. away from the cut-off wheel.
- Push on wheel (b) and turn in cut-off wheel attachment screw (11).
- Insert blocking pin (a) entirely into the blocking opening (12) and firmly tighten (30 Nm [22.1 ft·lbf]) the cut-off wheel attachment screw (11).
Securely hold the power tool at the top handle with one hand and push it firmly onto the ground.
- Remove the blocking pin (a).

5.2 Installing cut-off wheels with 1" inner bore



The power tool's spindle is designed for cut-off wheels with an inner bore of 20 mm. For proper installation of cut-off wheels with a 1" inner bore, the spindle adapter disk is required that is included with the delivery of the power tool.

The spindle adapter disk ensures correct fit of the 1" cut-off wheel on the spindle.

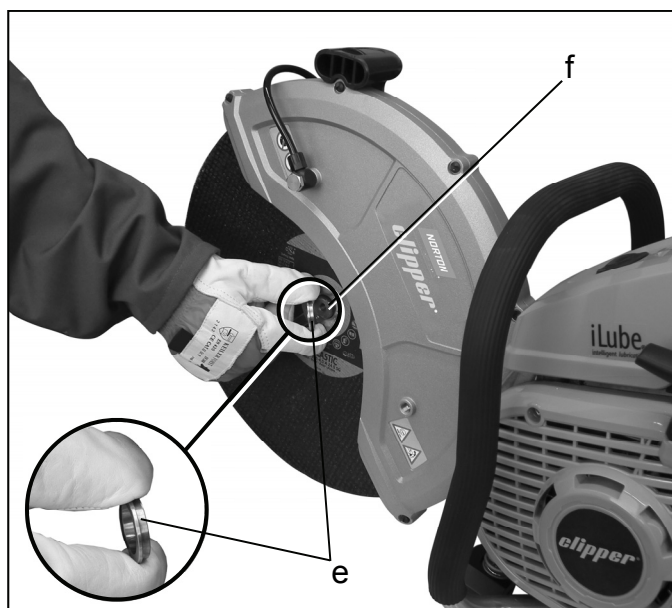

- Installation of cut-off wheels with 1" inner bore takes place according to chap. 5.1 as of page 16.
- After applying the cut-off wheel on the spindle, however, the spindle adapter disk (e) must be put on the spindle (f) additionally.
- Put the spindle adapter disk (e) onto the spindle so that it inserts between spindle and inner bore of the cut-off wheel.
The support area of the spindle adapter disk must point outwards in the installed condition, i.e. away from the spindle.
The correct orientation of the spindle adapter disk is mandatory to directly connect the plane inner area to of the outer mounting flange to the cut-off wheel. Only this warrants secure attachment of the cut-off wheel.
- Application of the outer mounting flange and all following steps must be performed again according to chap. 5.1.

5.3 Removing the cut-off wheel

- For cut-off wheel removal, the power tool must be put securely on the ground. Securely hold the power tool at the top handle with the left hand and push it firmly onto the ground. → Chap. 5.4, page 18
- Insert blocking pin (a) entirely into the cut-off wheel blocking opening (12) to block the spindle.
Unscrew cut-off wheel attachment screw (11).
Remove wheel (b) and outer mounting flange (c) (also see chap. 5.1).
- Remove cut-off wheel from the spindle. For cut-off wheels with a 1" inner bore, the spindle adapter disk also must be removed from the spindle.
- Put the outer mounting flange back onto the spindle so that the curved side points outward.
- Put on wheel (b) and turn in the cut-off wheel attachment screw (11) again. → Chap. 5.1.
- Insert blocking pin (a) entirely into the blocking opening (12) and firmly tighten (30 Nm [22.1 ft·lbf]) the cut-off wheel attachment screw (11) again.
Securely hold the power tool at the top handle with one hand and push it firmly onto the ground.
- Remove the blocking pin (a).

5.4 Adjusting wheel guard

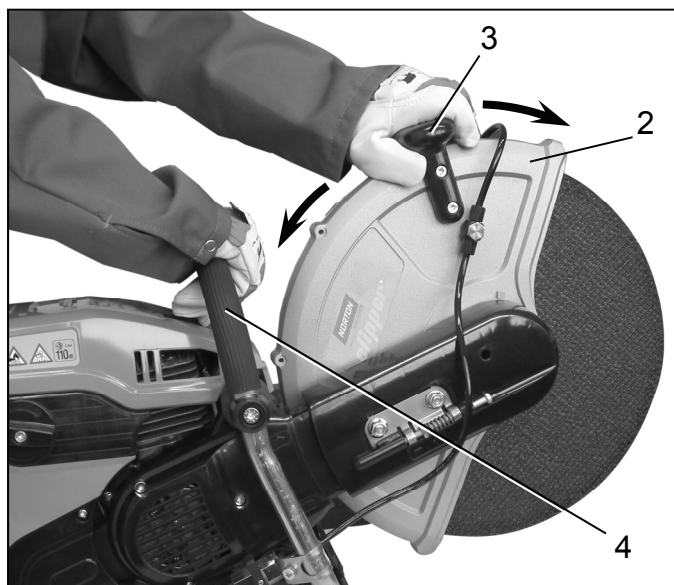

The wheel guard (2) can be rotated forward and backward in a limited area.

For adjustment of the wheel guard, the power tool must be put securely on the ground. Securely hold the power tool at the top handle (4) with the left hand and push it firmly onto the ground. With the right hand at the handle for wheel guard adjustment (3), rotate the wheel guard accordingly.

To keep sparks and particles away from the user, the wheel guard always must be rotated forward as far as the working situation permits.

 If the separating device has been installed in the outer position, ensure when adjusting the wheel guard that the water supply line is not clamped and that contact between the cut-off wheel and water supply line in operation is excluded.

5.5 Fuelling up

 **Danger to health!**
Direct skin contact with gasoline and breathing in of gasoline fumes must be excluded.

The high-performance two-stroke engine of this power tool requires an oil-gasoline mix in the combustion chamber (oil and gasoline = fuel mix).

Models CP512-300 and CP514-350



Models CP512-300 and CP514-350 are equipped with a fuel tank (18).

 Fuel tank for fuel mix according to the mix table below.

 Unsuitable fuels or deviations of the mix ratio may cause engine damage!

The fuel mix must be formed from the following components:

- Lead-free regular gasoline or lead-free super gasoline (octane number ≥ 92 RON)
- Branded 2-stroke engine oil corresponding to the standard ISO-L-EGD or JASO FD

Store the fuel mix no longer than 3 weeks.

Mix table for fuel mix:

Branded 2-stroke engine oil, 2 % (1:50)	Gasoline
0.020 l [0.68 oz]	1 l [33.8 oz]
0.040 l [1.35 oz]	2 l [67.6 oz]
0.100 l [3.38 oz]	5 l [169 oz]
0.200 l [6.76 oz]	10 l [338 oz]

Instead of a self-produced fuel mix, you may also use a pre-mixed special fuel mix for two-stroke motors. Recommendation: Use the special fuel mix of the brand "Aspen 2-stroke". The special fuel manufacturer's information must be observed.

Models CP512-300i and CP514-350i with iLube®

iLube®
intelligent lubrication

Models CP512-300i and CP514-350i are equipped with a fuel tank and an oil tank each that must be filled according to the specification below
The fuel mix is automatically formed during operation in these models (separate lubrication, iLube®, Intelligent Lubrication).

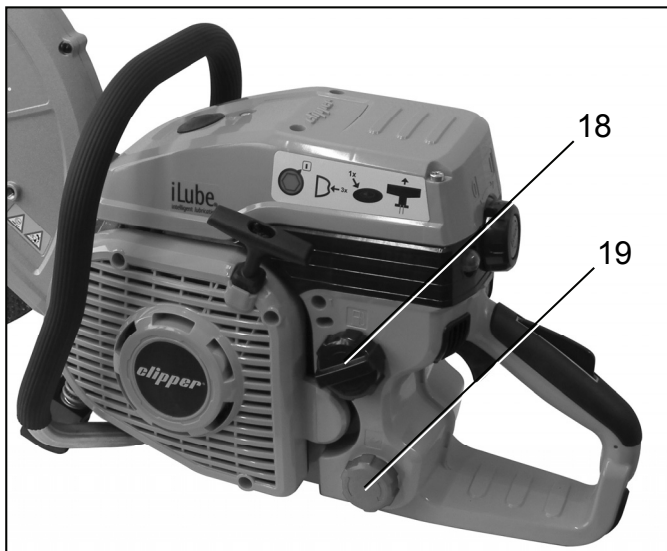

Fuel tank (18) for lead-free regular gasoline or lead-free super gasoline (octane number ≥ 92 RON).



Do not fill any fuel mix into the fuel tank (18)!



Oil tank (19, green cap) for branded 2-stroke engine oil corresponding to the standard ISO-L-EGD or JASO FD.



If there is not enough oil in the oil tank, the power tool will automatically reduce output even in the lower speed area and will not reach the speed required for work, which will be noticed by changed noise generation as compared to regular operation. At this point at the latest, oil must be refuelled.

Fill in operating media (fuel mix or gasoline and oil)

Observe the safety provisions when fuelling up. Fuel up only with the motor switched off.

- Clean the fill-in area well.
- Put down the motor device so that the fuel tank cap points up.
- Unscrew the tank cap.
- To avoid contamination in the tank, use a screen funnel if possible.
- Fill the tank no farther than to the lower edge of the nozzle.
- Screw on the tank cap tightly again until the overturning protection clearly "skips".
- After fuelling up, clean any splashed operating medium from the power tool.
- Never start or operate the power tool at the site of fuelling.

5.6 Adjusting the ribbed belt tension

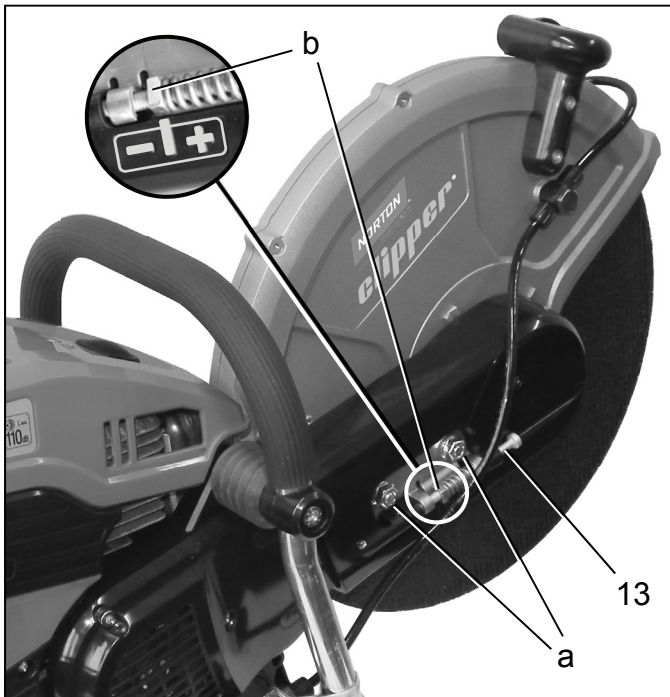

Generally, the ribbed belt tension must be set correctly when starting the power tool. At initial starting, at re-starting after extended stand still, after replacement of the ribbed belt or after any other assembly work, always check the tension and set the correct tension if required.

- Loosen both attachment nuts (a).
- Turn ribbed belt tensioning screw (13) towards the right (clockwise).
→ Increase ribbed belt tension.
The square nut (b) moves to the mark "+".
- Turn ribbed belt tension screw (13) towards the left (counter-clockwise):
→ Reduce ribbed belt tension.
The square nut (b) moves to the mark "-".
- The correct tension is reached when the square nut (b) is on the centre mark (c), in between "+" and "-".
- Tighten both attachment nuts (a) again.

5.7 Water connection for wet cutting

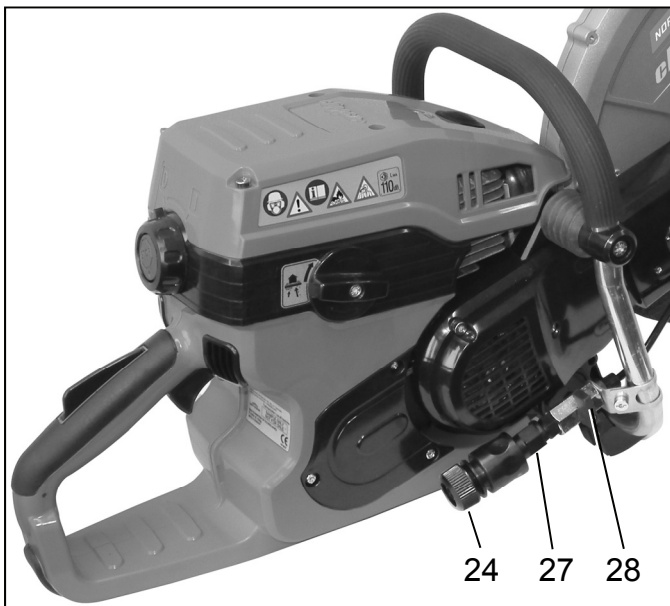

Fine dust occurs when cutting mineral materials. Recommendation: Use the water connection and cut-off wheels suitable for wet cutting when cutting mineral materials. When cutting with the water supply connected, the dust is suppressed, visibility is improved and the cut-off wheel service life is increased by the cooling effect of the water.

Before wet cutting:

- Connect suitable water line or suitable pressure tank to the coupling connection (24).
- Operate the valve lever (28) to open or close the water supply.

After wet cutting:

- Close the water supply, i.e. put the valve lever across the connection piece.
- Let the cut-off wheel run at high speed for another approx. 30 seconds to completely eject the water.



water supply opened
(valve lever parallel)



water supply closed
(valve lever across)

Cleaning the screen filter insert in the coupling piece (27): → Chap. 8.2, page 31

5.8 Relocate cutting device from centre position to outer position

The power tool is delivered for operation of the cut-off wheel in the centre position by default. Generally, the power tool is more balanced in the centre position, because the weight is distributed symmetrically to the centre axis and the cut therefore is easier to guide.

If obstacles are very close to the cutting location, it may be required to install the cutting device in the outer position so that the cut-off wheel is located farther towards the outside.



When working with the cut-off wheel in the outer position, observe the asymmetric weight distribution! If possible, work in the centre position.

Conversion from centre to outer position

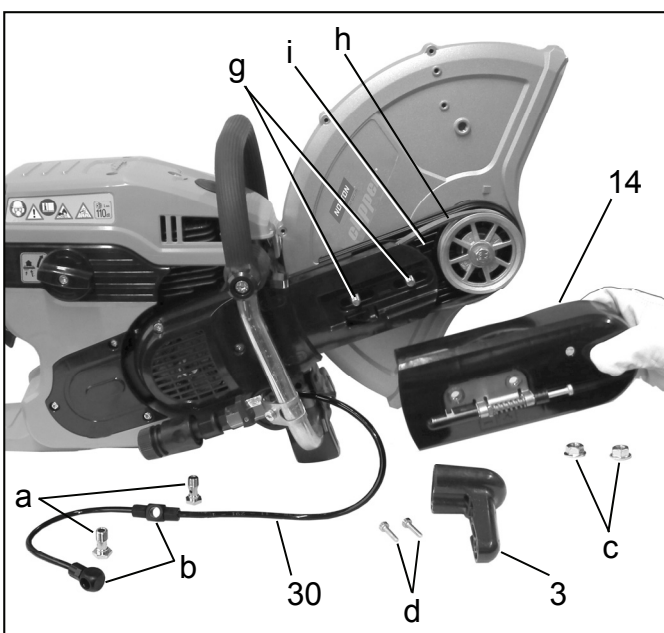
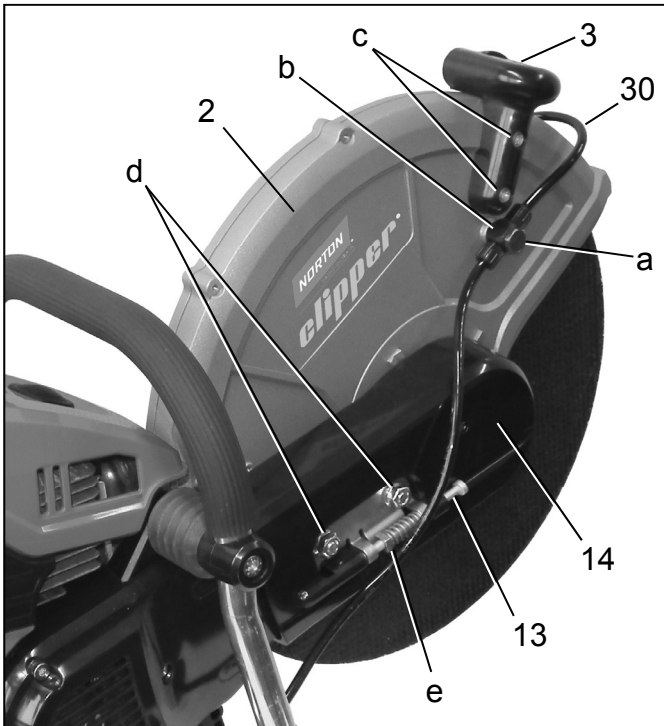

Preparation

- Put the power tool on level ground.
- Remove the cut-off wheel: → Chap. 5.3, page 17
- Remove the water supply line (30):
Unscrew the attachment screw (a) of the water supply line on the right and left sides of the wheel guard (2). Remove both adapter pieces (b) including the line from the wheel guard. Put down adapter pieces including line so that the line does not interfere with the following work steps and is not clamped.
- Remove handle for wheel guard adjustment (3). Loosen both attachment screws (c) of the handle for wheel guard adjustment and remove the handle.
- Loosen both attachment nuts (d) of the ribbed belt cover (14).
- Turn ribbed belt tension screw (13) towards the left, e.g. counter-clockwise, to reduce the ribbed belt tension.
Turn until the square nut (e) has been moved towards the mark "-" as far as possible. When installing the cutting device in the centre position (cf. figure), the square nut is all the way to the left; in case of installation in the outer position, it is located all the way to the right.
- Remove both attachment nuts (d) entirely.
- Remove the ribbed belt cover (14).

Remove wheel guard (2)

- Carefully move the wheel guard towards the motor unit. The screws (g) of the assembly flange (j) are moved within the oblong holes.
- Once the wheel guard has been moved towards the motor unit until the ribbed belt support (i) can be pulled through the ribbed belt (h), remove the wheel guard. Observe that the ribbed belt is not damaged by this.

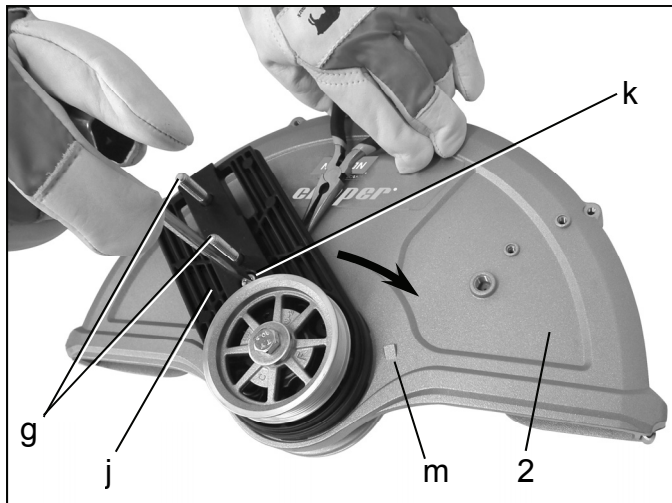

Loosen and turn assembly flange (j)

- Put the wheel guard on a level surface with the assembly flange (j) pointing up (screws (g) of the assembly flange point up).
- Turn out screw (k).
Hold the nut below the assembly flange with flat pliers.
- Twist the assembly flange against the wheel guard so that the receptacle bore for the screw (k) is located between the centre stop and the right stop (m) on the wheel guard. The assembly flange is hard to twist. Securely hold the wheel guard when twisting.

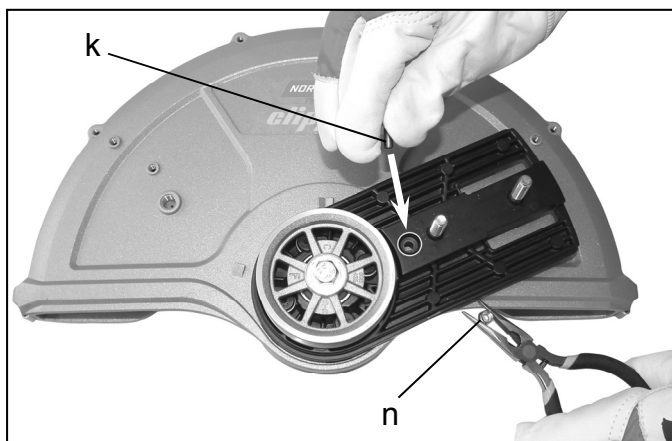

Limit wheel guard rotating angle with screw (k)

- Turn in screw (k) again.
For this, guide the nut (n) below the assembly flange with flat pliers and hold it when turning in the screw.
Turning of the wheel guard is limited by the stops on the wheel guard between which the nut can be moved.

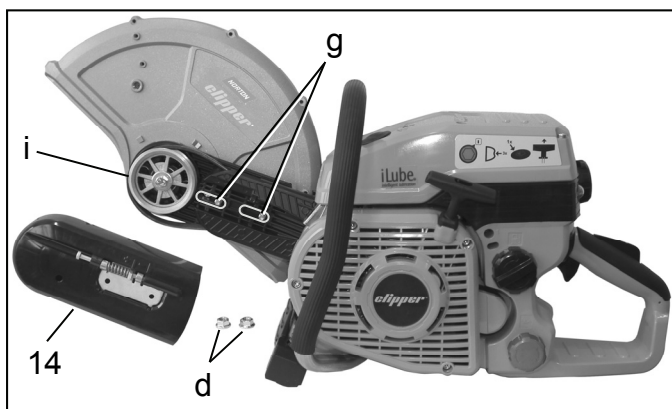

Install cutting device in the outer position

- Put the cutting device on the cutting device carrier in the outer position. For this, guide both screws (g) of the assembly flange through the oblong holes and put the ribbed belt support (i) into the ribbed belt.
- Check that the ribbed belt is running freely. Correct placement of the ribbed belt if required.
- Put on the ribbed belt cover (14) again.

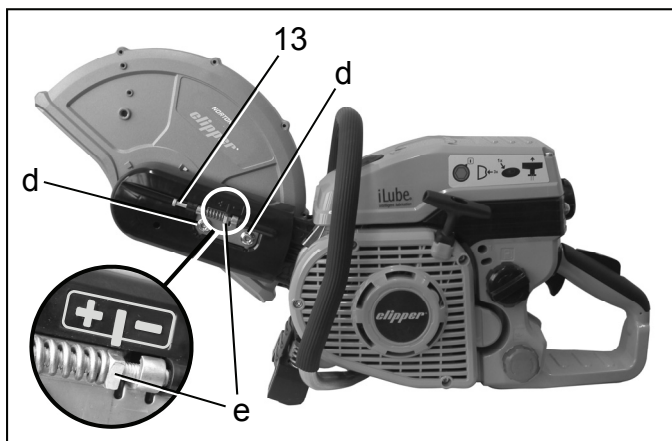

Adjust the ribbed belt tension

- Screw both attachment nuts (d) of the ribbed belt cover onto the assembly flange screws. Only tighten the nuts manually so that the ribbed belt tension can still be set.
- Turn ribbed belt tension screw (13) towards the right, e.g. clockwise, to increase the ribbed belt tension). The correct tension is reached when the square nut (e) is on the centre mark, i.e. between "+" and "-".
- Tighten both attachment nuts (d) firmly.

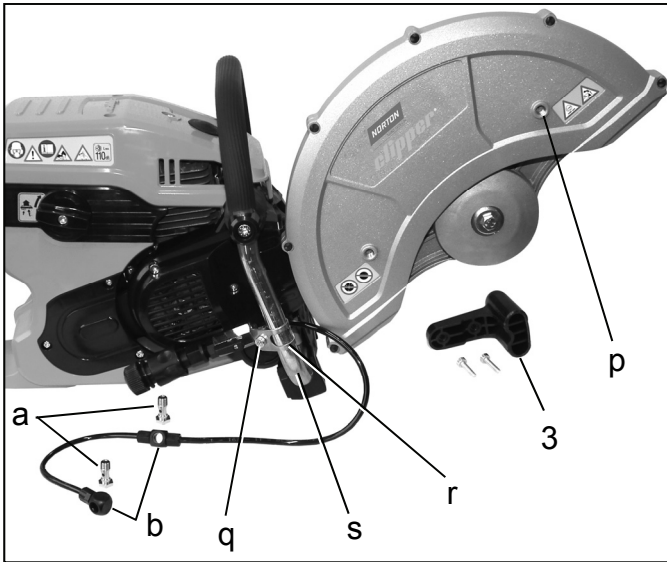

Move water supply line attachment upwards



The water supply line must be placed so that contact between water supply line and cut-off wheel in operation is excluded in all positions of the wheel guard.

- Place the water supply line so that it runs on the outside of the wheel guard and not between the wheel guard and the assembly flange.
- Push the attachment screws (a) of the water supply line into the adapter pieces (b).
- Place the adapter pieces on the right and left sides of the wheel guard above the associated threaded holes (p) and screw in the water supply line attachment screws.

- Loosen the screw (q) of the clamp (r) until the clamp can be moved upwards at the blank spar of the top handle (s).
- Push the clamp upwards so far that the water supply line can never be in contact with the cut-off wheel.
- Check placement of the water supply line when the wheel guard is rotated all the way to the front and correct if required.

Install handle for wheel guard adjustment and cut-off wheel again

- Install the handle for wheel guard adjustment (3) again to the wheel guard with the respective attachment screws.
- Install the cut-off wheel: → Chap. 5.1, page 16

5.9 Initial starting / run-in behaviour

After production, the power tool is subjected to an inspection and test process that ensures that the motor is then run in perfectly.

Therefore, no special measures are required for initial start-up.

6 Starting up and switching off the engine



Observe safety provisions!

6.1 Starting process



Starting preparations





- Put the power tool level and free from obstacles on the flat floor and observe that the cut-off wheel does not touch any objects.
- Put the wheel guard into the best position for the planned use. → Chap. 5.4, page 18

Automatic mixture control for cold and warm start

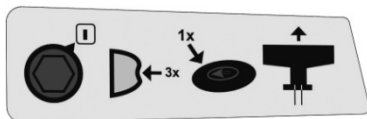
The power tool has an electronically controlled carburettor. Therefore, no special settings are required for cold or warm start (e.g. manual operation of a choke).

Starting notes



-  • Turn the stop dial to the operating position "1".
-  • Before the first start, operate the primer. → Chap. 4.5, page 14
-  • Before starting-up, push the decompression valve. → Chap. 4.5, page 14
- Put the power tool in start-up position. → Chap. 6.2, page 25
-  • Pull on the starter handle. → Chap. 6.3, page 25

6.2 Start-up position



Avoid any contact between the cut-off wheel and body parts or objects.

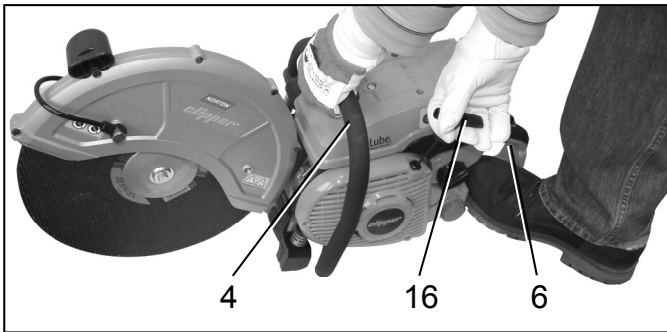

- Put one foot on the rear handle (6) to support the power tool against the floor.
- Securely hold the power tool at the top handle (4) with one hand and push it firmly onto the ground.
- Operate the starter handle with the other hand (16).

Other start-up positions are not permissible!

6.3 Switching on the engine



The following notes serve to increase the service life of the starter mechanism:

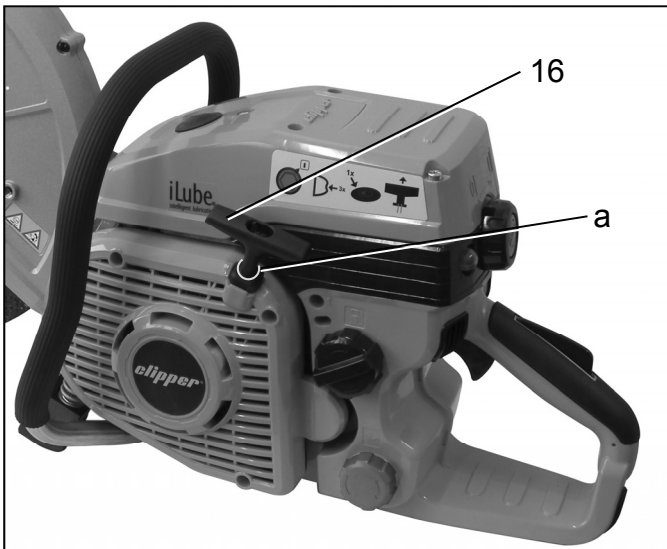

- Initially pull out the starter handle (16) slowly until resistance can be felt for start-up (upper dead point of the piston).
- Then quickly and strongly pull through the starter handle.
- Always pull out the rope straight.
- Do not let the rope scrape across the rope eyelet edge (a).
- Danger of breaking rope!
Do not pull out the rope to the stop.
- Always return the starter handle to its initial position – do not let it snap back.

Damaged starter ropes can be replaced by specialist workshops authorised by the manufacturer.

6.4 Switching off the engine

Release the throttle control and push the one-touch stop button.



Ensure that the cut-off wheel has stopped before putting down the power tool.

Recommendation: Turn the stop dial to "0" only for maintenance work to prevent accidental start-up of the engine. When operating the power tool, always push the one-touch stop button to switch off the engine.

7 Power tool use



 Always observe all safety notes and all other information in all chapters of these operating instructions for any work!

Check list for use (keywords only!) →

- Before start-up:
 - Power tool in an operationally safe condition! → Operating instructions complete
 - Prescribed work clothes → Chap. 3.3, page 7
 - Working area inspected and secured → Chap. 3.2, page 6, and chap. 3.9, page 10
 - Correct cut-off wheel firmly installed. → Chap. 5.1, page 16, and chap. 7.1, page 26
 - Wheel guard in best position → Chap. 5.4, page 18
 - Cutting device position, preferably centre position → Chap. 5.8, page 21
 - Ribbed belt tension correct → Chap. 5.6, page 20
 - Tool properly fuelled → Chap. 5.5, page 18
- Starting: → Chap. 6 complete, as of page 24
 - Starting preparations → Chap. 6.1, page 24
 - Stop dial in operating position → Chap. 6.1, page 24
- During work – generally safe work: → Operating instructions complete
 - Check idle settings → Chap. 8.3, page 32
 - Inspecting the working situation → Chap. 3.9, page 10, Chap. 7.2, page 27, and Chap. 7.3, page 28
 - Wet cutting preferred → Chap. 5.7, page 20
 - Secure working technique → Chap. 7.3, page 28, chap. 7.4, page 28, and chap. 7.5, page 29
 - Operating and maintenance notes complete → Chap. 8 complete, as of page 30
 - Air filter clean → Chap. 8.4, page 33
- After work: → Operating instructions complete
 - Cleaning and care → Chap. 8.1, page 30
 - Secure storage of power tool → Chap. 8.10, page 39
 - Maintenance → Operating instructions complete

7.1 Cut-off wheels



Only use cut-off wheels that correspond to the standards ANSI B7.1, EN 12413 and EN 13236 and that are undamaged.

The maximum spindle speed of the power tool is 4,450 min⁻¹ [4,450 rpm].

Only use high speed reinforced cut-off wheels marked with a permissible maximum operating speed of at least 4,450 min⁻¹ [4,450 rpm].

For processing of metals (hot cutting) and processing of mineral materials (cold cutting), different cut-off wheels are offered. Only use the cut-off wheel approved for the material being cut.

Diamond cut-off wheels are only approved for cutting mineral materials. When installing the diamond cut-off wheel, always observe the rotating direction indicated on the diamond cut-off wheel; otherwise, the cutting effect will reduce quickly from diamond loss.

Rotating direction of the cut-off wheel in the installed condition: → Chap. 5.1, page 16

Abrasive resin cut-off wheels must not be exposed to moisture. The water connection for wet cutting must not be used when using abrasive resin cut-off wheels. Abrasive resin cut-off wheels must not be used in high humidity or in rain. Only use abrasive resin cut-off wheels until the end of the best-before date imprinted on the receptacle ring of the cut-off wheel.

The power tool's spindle is designed for cut-off wheels with an inner bore of 20 mm.

Cut-off wheels with a 1" inner bore must only be installed with the spindle adapter disk supplied with the power tool.

Installation of cut-off wheels with 1" inner bore: → Chap. 5.2, page 17

Cut-off wheels with other inner bores must not be installed! Never modify the bore of the cut-off wheel!

New cut-off wheels must be tested for at least 60 seconds at the indicated maximum speed before the first cutting process. No body parts must be located in the extended swivel range of the cut-off wheel.

7.2 Permissible cutting area and danger from kickback or pinching

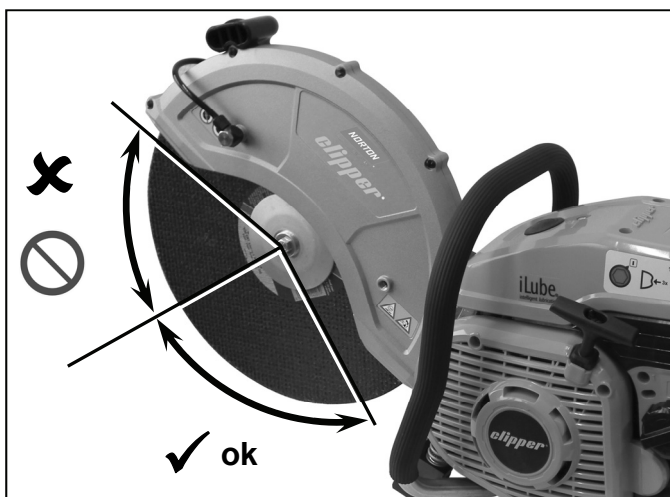

✘ The upper part of the cut-off wheel must not be used for cutting!

✓ Only the lower part of the cut-off wheel must be used for cutting!



Danger of injury from kickback!

Kickback results when the upper part of the cut-off wheel is used for cutting.

The power tool is pushed towards the user's head uncontrolledly and at high speed.

- Never cut with the upper area of the cut-off wheel!
- Take special care at insertion into cutting areas already started!



Danger of injury from pinching!

Pinching results when the cutting point becomes more narrow (crack or tensioned work piece).

The power tool is accelerated forwards uncontrolledly and under high energy.

- Always perform cutting and repeated insertion into cutting points already started at the maximum speed.
- Always support the work piece so that the cutting point is under tension so that the cut-off wheel is not clamped when cutting any further.
- When starting cutting, carefully move the cut-off wheel to the work piece; do not apply it suddenly.
- Never cut several work pieces at once!
- Ensure that no other work piece is touched when cutting.

7.3 Working behaviour and working technique

- For complex cutting processes, cutting direction and order of the cuts to be performed must be specified in advance to prevent pinching of the cut-off wheel by the removed part and injury from dropping parts.
- Always hold the power tool with both hands. Have the right hand on the rear handle, the left hand on the top handle. Firmly grasp the handles with your thumb.
- Operate the power tool at high speed when possible.
- Direction change (cutting radius below 5 m [approx. 15 ft]), side pressure, twisting or tilting of the power tool during cutting is forbidden.
- When shortening work pieces use a secure support and secure the work piece against slipping and twisting. The work piece must not be held with your foot or by another person.
- Always be ready for sudden kickback of the work piece and warrant the possibility of securely backing away.
- Make sure that cut-off sections cannot fall resulting in injury or property damage.

7.4 Cutting metal



Always wear breathing protection equipment at dry cutting.

Metals are heated and melted at the point of contact by the fast rotation of the cut-off wheel.

- Rotate the wheel guard down as far as possible for sparks to fly forward where possible, i.e. away from the user.
- Before cutting, specify and mark the cutting joint, and approach the material with the cut-off wheel at medium speed. Only when the guide groove is cut, continue cutting at full throttle and increased pressure.
- Only cut straight and vertically. Do not tilt or twist.
- For a secure and smooth cut, it is best to pull or to move the power tool in a controlled fashion. When moving the power tool, do not push the cut-off wheel into the material in addition to the thrust caused by the wheel's rotation.
- Large diameter round rods are best cut in steps.
- Thin tubes can be cut with a single sinking cut.
- Tubes with large diameters should be treated like large diameter rods. To avoid tilting and for better control of the cutting process, do not let the cut-off wheel sink into the material too far. Do not allow the mounting flanges of the cut-off wheel fastening to come into contact with the work piece.
- Double-T carriers or angled steel should be cut in steps.
- Steel bands or steel plates are cut like tubes; pulling flat with long cutting area.
- Material under stress (supported or material in a wall) always has to be grooved slightly on the compression side and then cut from the tension side so that the cut-off wheel is not pinched.

7.5 Cutting mineral materials

Cutting mineral materials such as concrete creates a lot of fine dust.

Recommendation: Use the water connection of the power tool and cut-off wheels suitable for wet cutting when cutting mineral materials.

When cutting with water supply, the dust is reduced, visibility is improved and the cut-off wheel service life is increased by the cooling effect of the water.

Water connection for wet cutting: → Chap. 5.7, page 20

Small pieces of mineral materials may be ejected from the cutting groove by the quick rotation of the cut-off wheel.

- Rotate the wheel guard down as far as possible so the cut particles are ejected away from the user.
- Mark the cutting line and grind a groove of approx. 5 mm [approx. 3/16"] along the entire line at half throttle that will guide the power tool precisely for the subsequent cutting process.
- Perform the cutting process with even movements back and forth.
- When fitting stone plates, application of a flat groove is sufficient (avoiding unnecessary dust formation), to then cleanly strike off the protruding piece on a flat support.

8 Operating and maintenance notes



Maintenance and repairs of state-of-the-art power tools and their safety-relevant assemblies require qualified specialist training and a workshop equipped with special tools and test devices.

Recommendation: Have all work not described in these operating instructions and all work you are not comfortable with be performed by a specialist workshop authorised by the manufacturer. The specialist has the required training, experience and equipment and can make the most cost-efficient solution available to you. He will advise and support you.



Observe the safety provisions for any maintenance work!



After a run-in time of approx. 5 operating hours, all screws and nuts that can be reached (except for carburettor adjustment screws) must be checked for tight fit and tightened again if required.

It is best to keep the power tool in a dry and safe site with a full fuel tank.

There must not be any open sources of fire or the like nearby.

Before extended storage (>4 weeks), observe the notes in chap. 8.10 on page 39.

8.1 Cleaning and care



The power tool must be cleaned thoroughly after every use and checked for damage; in particular the cooling air openings in the starter housing must be clean and free.

Inside the wheel guard, material deposits will form over time (in particular when wet cutting), which may impair free rotation of the cut-off wheel.

Only use the environmentally compatible cleaning agents offered by specialist vendors for cleaning. Never use fuel to clean!

- Disassemble cut-off wheel and outer mounting flange. → Chap. 5.3, page 17
- Remove material deposits inside the wheel guard with a wood bar or similar.
- Clean spindle and all disassembled parts and check them for damage.
- Clean cut-off wheel and check it for damage. If any damage is found, dispose of the cut-off wheel properly and immediately so that it is not reused in the next work deployment.
- Inspect the wheel guard for damage. If damaged, replace the wheel guard by an undamaged wheel guard before using the power tool and dispose of the damaged wheel guard properly and immediately.
- Install outer mounting flange, any other parts and cut-off wheel again. → Chap. 5.1, page 16

8.2 Cleaning the screen filter insert of the connection piece



The connection piece for the water supply line for wet cutting is equipped with a screen filter insert to prevent closure of the water supply line by contamination in the supplied water.

Water connection for wet cutting: → Chap. 5.7, page 20



Danger of contamination for the water supply line!
Only open the water connection in a clean environment.

At a weekly interval or when there is no longer enough water supplied for wet cutting, the screen filter insert of the connection piece must be removed as follows and cleaned thoroughly:

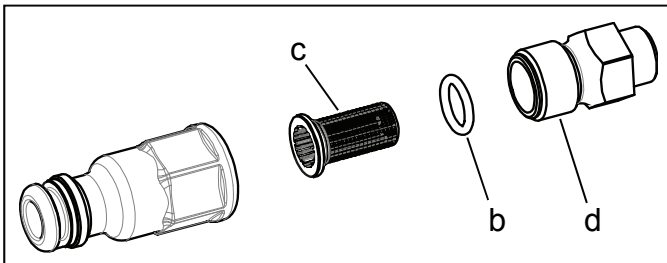
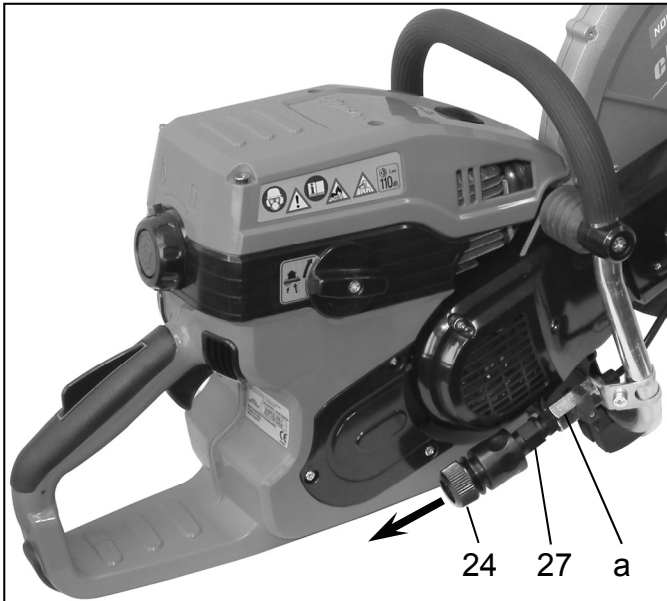

- Switch off the engine and turn the stop dial to "0". Switching off the engine: → Chap. 6.4, page 25
- Remove the connection of the water supply line. For this, remove the coupling connection (24) from the screen filter connection piece (27) of the water supply line in the direction of the arrow.
- Turn out screen filter connection piece with suitable open-faced spanner from connection (a) of the water supply line.
- Disassemble screen filter connection piece (27) with suitable open-faced spanner.
- Remove screen filter insert (c) from screen filter receptacle (d) of the connection piece.
- Remove seal (b) from the screen filter insert.
- Flush the screen filter insert, the coupling connection, both parts of the screen filter connection piece and the seal with clean water until all residue of contamination has been removed.
- Push the seal (b) again on the screen filter insert.
- Re-insert the screen filter insert with the seal (b) in the screen filter receptacle (d) of the connection piece in the correct direction (see figure).
- Screw together the screen filter coupling piece.
- Screw the screen filter coupling piece into the connection (a) of the water supply line again.
- Push on the coupling connection again.

8.3 Idle/carburettor adjustment



-  The cut-off wheel must not rotate when idling!
The idle position must be inspected every time when taking up work and corrected if required.

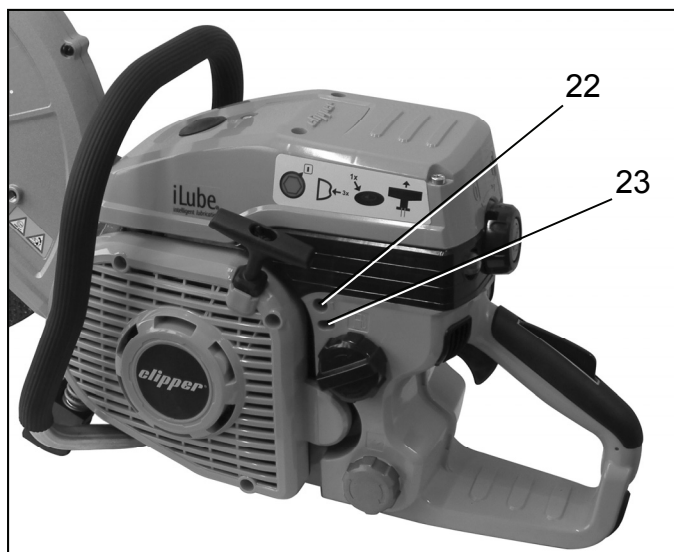

For correct idle position, the motor should run smoothly in the idling mixture without driving the cut-off wheel.

The carburettor is preset perfectly at the factory. Depending on site of deployment, the idle settings may have to be adjusted via the idle stop screw "T" (22).

The carburettor adjustment screws "L" (idle mix control) and "H" (full load mix control) (23) must only be set by specialist workshops authorised by the manufacturer.

Idle stop screw "T"

The idle stop screw "T" can be adjusted with the small screwdriver from the delivery.

The air filter must be clean for correct adjustment. Air filter maintenance: → Chap. 8.4, page 33
Let the engine warm up before performing adjustments.

To set the idle speed indicated in the technical data (chap. 4.6, page 15), proceed as follows – preferably using a speed meter:

- Idle speed too high (in particular if the cut-off wheel is already driven without throttle):
→ Open the idle stop screw "T" counter-clockwise a little.
- Idle speed too low (i.e. the engine goes out with the idling mixture):
→ Close the idle stop screw "T" clockwise a little until the engine runs smoothly with the idling mixture without going out.

If a perfect carburettor setting cannot be achieved by turning the idle stop screw "T", have the carburettor set by a specialist workshop authorised by the manufacturer.

8.4 Air filter maintenance



A contaminated air filter will reduce output. Fuel consumption and hazardous substance quantity in the exhaust increase. Starting is made more difficult as well.

Interim emptying of the air filter



Turn vibration dial (29) to perform rough interim emptying of the air filter during work. The air filter box and air filter are shaken so that loose dust falls off. Slightly tilt the power tool back and let dust fall out of the intake openings. Turn the vibration dial repeatedly if required.

Cleaning the air filter

At weekly intervals or when the engine output is clearly reduced, the air filter must be removed and cleaned thoroughly.



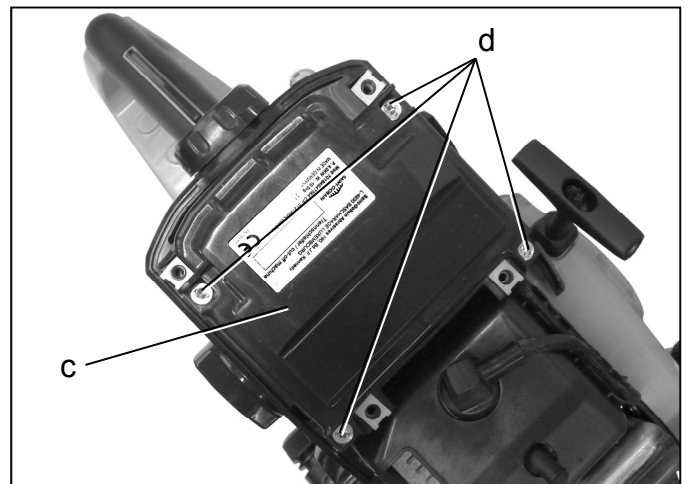
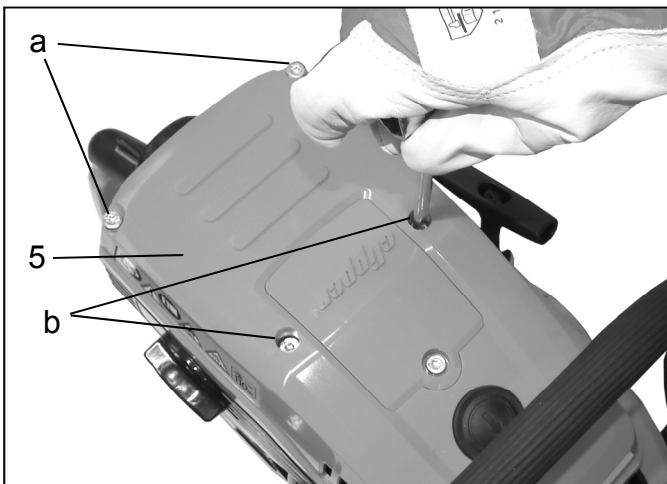

Danger of contamination for the filter inside!
Only open the guard and air filter box lid in a clean environment.

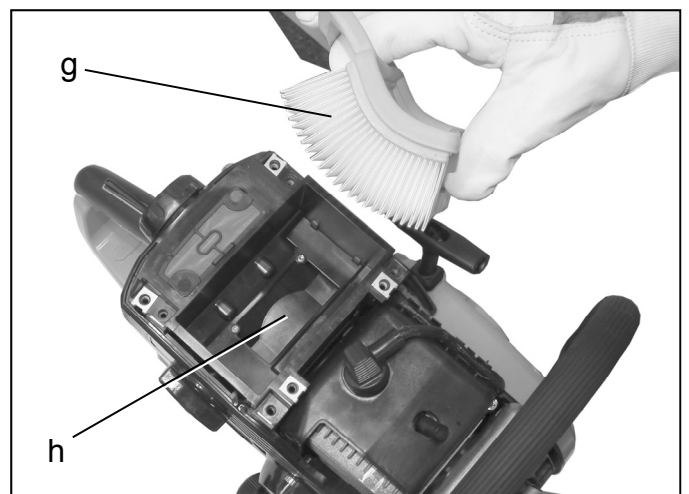

- Switch off the engine and turn the stop dial to "0". Switching off the engine: → Chap. 6.4, page 25
- Loosen all four attachment screws (a) and (b) of the guard (5). Remove guard.
- Loosen all four attachment screws (c) of the air filter box lid (d) and take off the air filter box lid.



 The fine-mesh cover (f) and the air filter (g) must not be cleaned wet or with compressed air.

 Danger of engine damage from insufficient filter effect!
Replace damaged filter material at once!

- Take air filter by the air filter frame (e) and remove upwards.
- Simple contact or brush out of the individual paper layers (g) is best to clean the air filter.
- Take power tool with both hands to empty the air filter box (h).
- De-dust fine-meshed cover (f) next to the air filter box with a dry brush.
- Insert air filter again.
- Install housing parts again.

 At re-installation of the housing parts, ensure correct placement of the housing parts, use the corresponding screws and tighten all screws again.
The guard attachment screws (a) and (b) must not be swapped. The two guard attachment screws (b) are shorter than the screws (a).

8.5 Spark plugs check and replacement if required



 Danger of contamination for the power tool inside!
Only open the spark plug cover in a clean environment.

The spark plug must be inspected regularly every 50 operating hours.

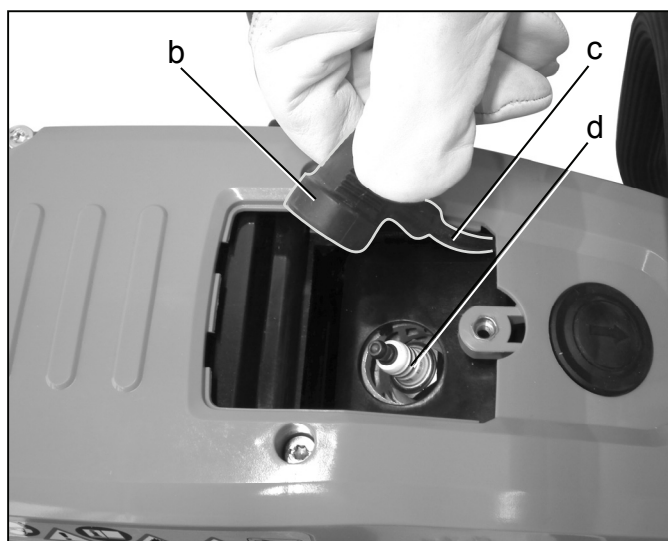
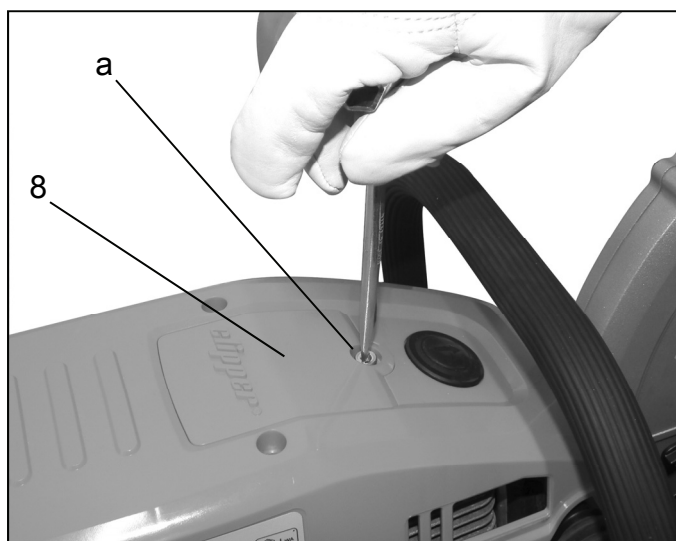

- Switch off the engine and turn the stop dial to "0". Switching off the engine: → Chap. 6.4, page 25
- Loosen attachment screw (a), lift spark plug cover (8) by the tab and then remove it.
- Remove spark plug connector (b) from the spark plug (d) below.

 Danger of fire from spark formation!
Do not start up the engine with the spark plug (d) unscrewed or the ignition cable (c) removed from the plug.

- Unscrew spark plug (d) and dry off well.
- Clean spark plug with dry cloth and check electrodes. There must not be any foreign material between the electrodes. Brush out any foreign bodies with a spark plug brush.
- If the electrodes are strongly burned down, the spark plug must be replaced at once – otherwise, it must be replaced after 100 operating hours.



- Proper electrode distance: 0.5 mm [approx. 0.02"]
Replace the spark plug if the electrode distance is incorrect.
The following interference-suppressed spark plugs are approved for use in this power tool:
BOSCH WSR6F, CHAMPION RCJ-6Y and NGK BPMR7A
Use of other spark plugs is not allowed!

- Check ignition cable (c) for proper connection and intact insulation. If the insulation is damaged, do not continue work, but order repair from a specialist workshop charged by the manufacturer.
- Screw in spark plug (d) again. Torque: 25 Nm [18.4 ft·lbf]
- Push the spark plug connector (b) onto the spark plug (d) firmly at reattachment.
- Re-install the spark plug cover (8).

8.6 Ribbed belt replacement



- ! Danger of contamination of ribbed belt, associated carrier structure and coupling!
Only open the ribbed belt cover and coupling cover in a clean environment.

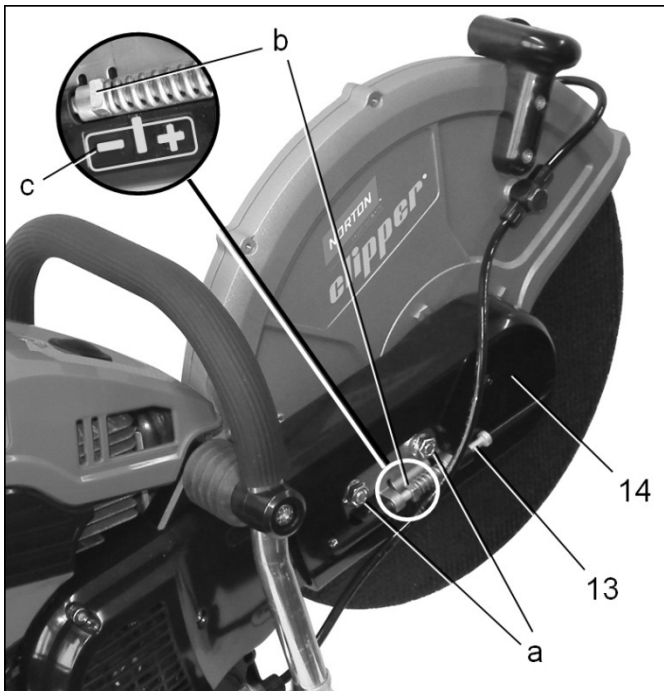

- Switch off the engine and turn the stop dial to "0".
Switching off the engine: → Chap. 6.4, page 25
- Shut off water supply to the power tool.
- Put the power tool on level ground.
- Loosen both attachment nuts (a) of the ribbed belt cover (14).
- Turn ribbed belt tension screw (13) towards the left, e.g. counter-clockwise, to reduce the ribbed belt tension.
Turn until the square nut (b) has been moved towards the mark "-" (c) as far as possible.
When installing the cutting device in the centre position (cf. figure), the square nut is all the way to the left; in case of installation in the outer position, it is located all the way to the right.
- Remove both attachment nuts (a) entirely.
- Remove the ribbed belt cover (14).

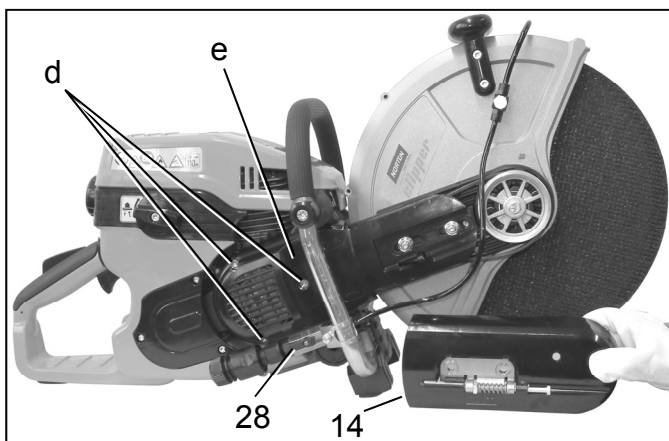

- Screw the attachment nuts (a) of the ribbed belt cover (14) onto the associated screws again and tighten only slightly so that the separating device cannot fall off again.
- Loosen all 3 attachment screws (d) of the coupling cover (e).
The screws only need to be loosened until they can be turned very easily. It is not necessary to turn out the screws entirely, since the screws should remain in the cover.

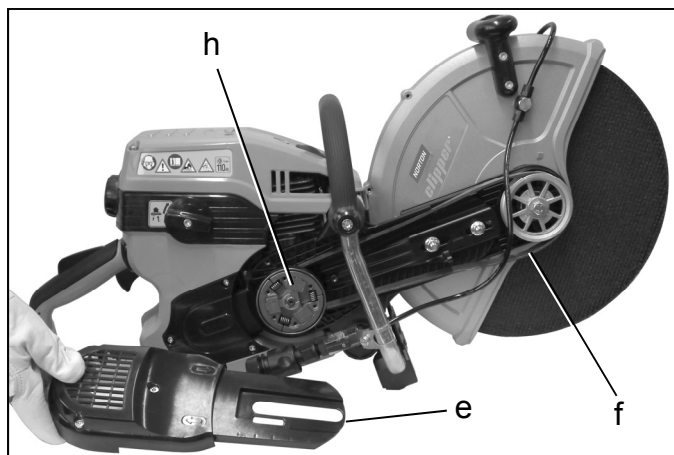

- Put the valve lever (28) for the water supply parallel to the connection piece so that it does not interfere with the following work step.
- Remove the coupling cover (e).
- Remove the old ribbed belt (f) or any residue of the old ribbed belt and any other foreign bodies.
- Use a small brush or paintbrush to clean the open area.
- Place a new ribbed belt on the grooved running surface (g) on the drive side behind the coupling bell (h).

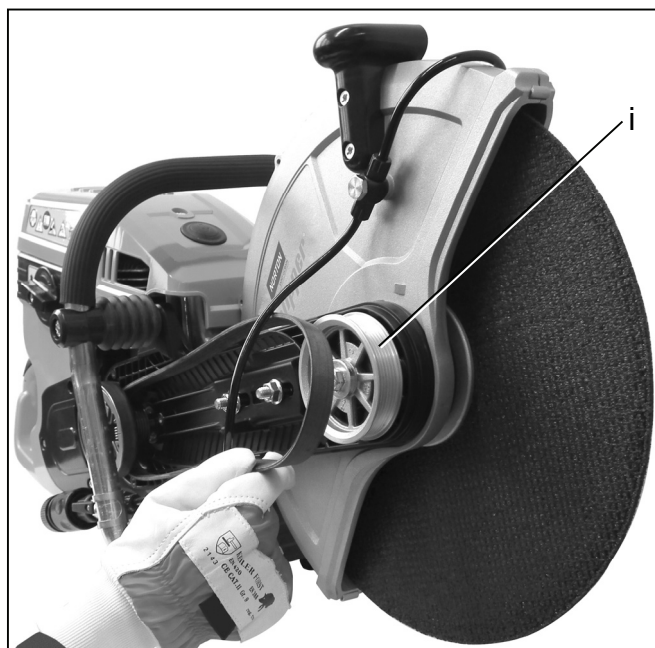
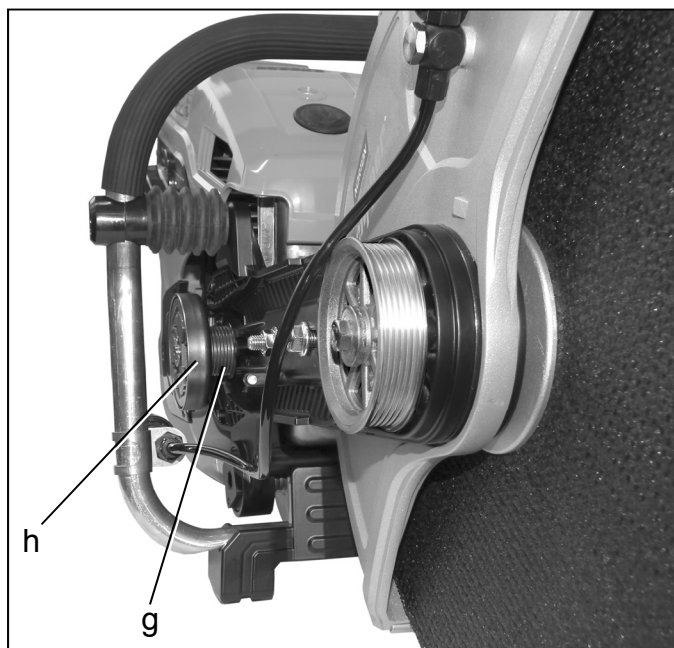

- Put the other side of the ribbed belt on the grooved running surface (i) of the ribbed belt support on the output side. Check that the ribbed belt is running freely. Correct placement of the ribbed belt if required.
- Put on the coupling cover again and check that the ribbed belt is still running freely. If required, remove the coupling cover again and correct placement of the ribbed belt.
- Tighten all 3 attachment screws (d) of the coupling cover (e) again.
- Check that the ribbed belt is still running freely. If required, loosen the coupling cover screws again and correct placement of the ribbed belt.
- Unscrew both attachment nuts (a) of the ribbed belt cover again.
- Put on the ribbed belt cover (14) again.
- Screw on both attachment nuts (a) of the ribbed belt cover again. Only tighten the nuts manually so that the ribbed belt tension can still be set.
- Turn ribbed belt tension screw (13) towards the right, e.g. clockwise, to increase the ribbed belt tension). The correct tension is reached when the square nut (b) is on the centre mark, i.e. between "+" and "-".
- Tighten both attachment nuts (a) of the ribbed belt cover.
- Close the water supply valve lever, i.e. put the valve lever across the connection piece.

8.7 Fuel filter replacement



The fuel filter in the fuel tank must be replaced as part of the annual customer service in a specialist workshop required by the manufacturer.

8.8 Maintenance plan









The following notes refer to regular usage situation.
Under special conditions, such as long daily working times, the maintenance intervals stated must be reduced accordingly.

Perform maintenance work at regular intervals.
Charge a specialist workshop authorised by the manufacturer if you cannot perform all work on your own.

The owner of the power tool is also responsible for:

- Damage from unprofessional or belated maintenance or repair work
- Subsequent damage – also corrosion – in case of improper storage

		Once after 5 operating hours	Before and during each working operation	Weekly	Every 50 operating hours	Every 100 operating hours	On demand	At start-up/annually
	Cooling air openings in the starter housing	Clean	X				X	
	Carburettor → Chap. 8.3, page 32	Check idling	X					
		Set idling (screw "T")					X	
		Set carburettor (screws "L"/"H") (for specialist workshops only)						X
	Air filter → Chap. 8.4, page 33	Interim emptying of the air filters	X				X	
		Clean air filter thoroughly		X			X	
		Replace						X
	Screen filter of the water supply line → Chap. 8.2, page 31	Clean		X			X	
	Spark plug → Chap. 8.5, page 34	Check firm seat of ignition cable and spark plug connector	X				X	
		Check electrode distance and replace spark plug if required			X			X
		Replace				X	X	
	All screws in reach (except for adjustment screws)	Re-tighten	X				X	X
	Operating units (stop button/switch, throttle control, throttle control lock, starter)	Check function		X				
	Entire power tool	Visual condition inspection		X				
		• Check cut-off wheel and muffler for damage.						
		• Check tank cap for tightness						
		• Check ribbed belt tension → chap. 5.6, page 20		X				
		Clean		X			X	X

Furthermore, a specialist workshop authorised by the manufacturer must be charged, among others, with the following service in the scope of the annual customer service:

- Complete inspection of the entire power tool
- Professional motor cleaning (fuel tank, cylinder ribs, ...)
- Inspection and, if applicable, replacement of the wear parts, in particular annual replacement of the fuel filter
- Best settings of the carburettor

8.9 Self-aid advice

Possible malfunctions:



- Engine does not start up
 - Stop dial
 - Turn the stop dial to the operating position "1". → Chap. 6.1, page 24
 - Spark plug
 - Clean or replace → Chap. 8.5, page 34
 - Old fuel
 - Empty and clean tank, fuel up with fresh fuel → Chap. 5.5, page 18
- Cut-off wheel is not accelerated properly
 - Foreign body inside the wheel guard
 - Clean wheel guard → Chap. 8.1, page 30
 - Ribbed belt tension too low
 - Correctly set ribbed belt tension → Chap. 5.6, page 20
- Cut-off wheel rotates in idle operation
 - Idle stop screw "T"
 - Correctly adjust idle stop screw "T" → Chap. 8.3, page 32
 - Coupling defective
 - Service workshop
- Bad engine output
 - Air filter clogged
 - Clean air filter thoroughly → Chap. 8.4, page 33
 - Carburettor settings (L/H-settings)
 - Service workshop
- Insufficient or no water supply in wet cutting
 - Valve lever of the water supply line not opened
 - Open valve lever → Chap. 5.7, page 20
 - Connection of the water supply closed
 - Open water supply
 - Water supply pressure tank empty or pressure-relieved
 - Replenish water or recover pressure supply
 - Screen filter insert contaminated
 - Thoroughly clean screen filter insert → Chap. 8.2, page 31
- Changed noise emission and motor does not reach high speeds (only for models CP512-300i and CP514-350i)
 - Not enough engine oil in the oil tank
 - Fuel up engine oil → Chap. 5.5, page 18

8.10 Shutting down and storage

Before shutting down and storage, the power tool must be cleaned thoroughly and checked for damage.

Cleaning and care: → Chap. 8.1, page 30

Only store the power tool in dry rooms. There must not be any open sources of fire or the like nearby.

Prevent unauthorised use – in particular by children.

Before extended storage, (>4 weeks) additionally empty the tanks for operating materials in a well-ventilated location and clean them. Start engine with the fuel tank empty and empty the carburettor until the engine goes out. Oil residue from the fuel lubrication may otherwise close the carburettor nozzles and make start-up more difficult later.

9 Warranty

The manufacturer warrants perfect quality and assume the costs for any subsequent improvement by replacement of defective parts in case of material or production errors that occur during the warranty period after the day of sale. Please observe that specific warranty conditions apply in some countries. In doubt, ask your vendor. He as a vendor of the product is responsible for the warranty.

Please understand that the manufacturer cannot assume any warranty for the following damage causes:

- Failure to follow the operating instructions.
- Failure to perform required maintenance and cleaning.
- Damage due to improper carburettor settings.
- Normal wear and tear.
- Obvious overload.
- Use of other than approved working tools.
- Application of force, improper treatment, misuse, abuse or accident.
- Overheating damage due to contamination of the fan housing.
- Actions performed by unqualified staff, improper repair attempts or repairs by unauthorised personnel.
- Use of unapproved replacement parts or other than original parts if they caused the damage.
- Use of unsuitable or outdated operating materials.
- Damage due to the usage conditions from renting.

Cleaning, care and adjustment work are not deemed warranty services.

Warranty services must be ordered from a specialist workshop authorised by the manufacturer.

10 Wear parts

Several components are subject to wear in operation or regular wear and may have to be replaced in time.

The following wear parts are not subject to the manufacturer's warranty:

- Operating materials
- Air filter
- Fuel filter
- Clutch
- Spark plug
- Starting device
- Cut-off wheel

11 EC Declaration of conformity

Saint-Gobain Abrasives; 190, Bd. J. F. Kennedy; 4930 BASCHARAGE, LUXEMBOURG, declares that the following machine as delivered complies with the provisions in implementation of the following EC directives: 2006/42/EC, 2000/14/EC (Annex V) and 2004/108/EC

Product designation: Cut-off machine
 Type designation CP512, CP514
 Trade designation: CP512-300, CP512-300i, CP514-350, CP514-350i

Applied standards: EN ISO 19432:2012, EN ISO 12100:2010, EN 55012:2007+A1:2009

Valid for machines as of serial number: 5123000-xxxx-001001, 5123001-xxxx-001001, 5143500-xxxx-001001, 5143501-xxxx-001001 and the following serial numbers.

Sound power level pursuant to 2000/14/EC: warranted: 110 dB(A), measured: 108 dB(A)

Storage site for the technical documents pursuant to 2000/14/EC and 2004/108/EC: Saint-Gobain Abrasives; 190, Bd. J. F. Kennedy; 4930 BASCHARAGE, LUXEMBOURG

This declaration of conformity loses its validity when the product is converted or modified without agreement.

Bascharage, 31.01.2013

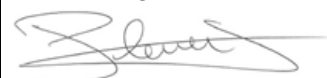

Olivier Plenert, executive officer

SAINT-GOBAIN ABRASIVES N.V.
HEIDE 10
1780 WEMMEL
BELGIUM
TEL: +32 2 267 21 00
FAX: +32 2 267 84 24

SAINT-GOBAIN ABRASIVES, S.R.O.
VINOHRADSKÁ 184
130 52 PRAHA 3
CZECH REPUBLIC
TEL: +420 267 132 026
+420 267 132 029
FAX: +420 267 132 021-2

SAINT-GOBAIN ABRASIVES A/S
ROBERT JACOBSENS VEJ 62A
2300 KØBENHAVN S
DENMARK
TEL: +45 4675 5244

PO BOX 643706
FORTUNE TOWER OFFICE 2106
JLT BLOCK C
(NEXT TO METRO STATION)
JUMEIRA LAKE TOWER, DUBAI
UNITED ARAB EMIRATES
TEL: +971 4 431 5154
FAX: +971 4 431 5434

SAINT-GOBAIN ABRASIFS
RUE DE L'AMBASSADEUR - B.P.8
78 702 CONFLANS CEDEX
FRANCE
TEL: +33 (0)1 34 90 40 00
FAX: +33 (0)1 39 19 89 56

SAINT-GOBAIN ABRASIVES GMBH
BIRKENSTRASSE 45-49
50389 WESSELING
GERMANY
TEL: +49 2236 703-1
+49 2236 8996-0
+49 2236 8911-0
FAX: +49 2236 703-367
+49 2236 8996-10
+49 2236 8911-30
FÜR DEN FACHHANDEL
ÖSTERREICH
TEL: +43 (00) 662 430 076

SAINT-GOBAIN ABRASIVES KFT.
1225 BUDAPEST
BÁNYALÉG U. 60/B.
HUNGARY
TEL: +36 1 371 22 50
FAX: +36 1 371 22 55

SAINT-GOBAIN ABRASIVI S.P.A
VIA PER CESANO BOSCONI 4
I-20094 CORSICO MILANO
ITALY
TEL: +39 02 44 851
FAX: +39 02 44 78 266

SAINT-GOBAIN ABRASIVES S.A.
190 RUE J.F. KENNEDY
L-4930 BASCHARAGE
GRAND DUCHE DE LUXEMBOURG
TEL: +352 50 401 1
FAX: +352 50 16 33
NO. VERT (FRANCE) 0800 906 903

SAINT-GOBAIN ABRASIFS, S.A.
2 ALLÉE DES FIGUIERS
AIN SEBAÄ - CASABLANCA
MOROCCO
TEL: +212 5 22 66 57 31
FAX: +212 5 22 35 09 65

SAINT-GOBAIN ABRASIVES BV
GROENLOSEWEG 28
7151 HW EIBERGEN
P.O. BOX 10
7150 AA EIBERGEN
THE NETHERLANDS
TEL: +31 545 466466
FAX: +31 545 474605

SAINT-GOBAIN ABRASIVES AS
POSTBOKS 11, ALNABRU,
0614 OSLO
BROBEKKVEIEN 84,
0582 OSLO
NORWAY
TEL: +47 63 87 06 00
FAX: +47 63 87 06 01

SAINT-GOBAIN HPM
POLSKA SP. Z O.O.
UL. TORUŃSKA 239/241
62-600 KOŁO
POLAND
TEL: +48 63 26 17 100
FAX: +48 63 27 20 401

SAINT-GOBAIN ABRASIVOS, L. DA
ZONA INDUSTRIAL DA MAIA
I-SECTOR VIII, NO. 122
APARTADO 6050
4476 - 908 MAIA
PORTUGAL
TEL: +351 229 437 940
FAX: +351 229 437 949

SAINT-GOBAIN ABRASIVI SRL
PARC INDUSTRIAL HOLROM
DRUM CAREI NR. 11
447355 VETIS JUD. SATU-MARE
ROMANIA
TEL: +40 261 450 009
FAX: +40 261 750 010

SG HPM RUS
58, F. ENGELS STR.
STROENIE 2
105082 MOSCOW
RUSSIA
TEL: +74 955 408 355
FAX: +74 959 373 224

SAINT-GOBAIN
ABRASIVES (PTY) LTD
2 MONTEER ROAD
ISANDO 1600
P.O. BOX 67
SOUTH AFRICA
TEL: +27 11 961 2000
FAX: +27 11 961 2184/5

SAINT-GOBAIN ABRASIVOS, S.A.
CTRA. DE GUIPÚZCOA, KM. 7,5
E-31195 BERRIOPLANO
(NAVARRA)
SPAIN
TEL: +34 948 306 000
FAX: +34 948 306 042

SAINT-GOBAIN ABRASIVES AB
BOX 495
SE-191 24 SOLLENTUNA
SWEDEN
TEL: +46 8 580 881 00
FAX: +46 8 580 881 01

SAINT-GOBAIN ABRASIVES
MUEYETZADE MAH.
GALIPDEDE CAD. NO:99, KAT:3
34425 BEYOGLU-ISTANBUL-
TURKEY
TEL: 0090-212-245 85 21
FAX: 0090-212-245 85 27

SAINT-GOBAIN ABRASIVES LTD.
DOXEY RD
STAFFORD
ST16 1EA
UNITED KINGDOM
TEL: +44 1785 222 000
FAX: +44 1785 213 487

www.construction.norton.eu

Saint-Gobain Abrasives S.A.

190, Bd. J. F. Kennedy
L-4930 BASCHARAGE
LUXEMBOURG

Tel: +352 50401-1

Fax: +352 50163-3

e-mail: sales.nlx@saint-gobain.com