

JUMBO 900-1000 Elec

SPARE PART LIST

LISTE DE PIÈCES DE RECHANGE

ERSATZTEILLISTE



NORTON
SAINT-GOBAIN

clipper



ENGLISH

TYPE:

S = Spare part

W = Wear part

NA = Not Available

The kits of spare parts contain all screws and bolts and the components referring itself to it.

Screws and bolts is component of standard assembly, which you can easily find at all the retailers of standard components of assembly.

All the components of standard assembly are of a quality grade 8.8.

We recommend not to use a quality grade lower than 8.8 for all the standard components of assembly.

The parts of replacements Norton CLIPPER must always be used.

Wear parts life will vary based on usage and maintenance of the machine or part. Wear parts will need to be maintained and replaced as needed. No warranty is applied to wear parts.

The components NA (Not Available) are not available in spare part.

FRANCAIS

TYPE :

S = Pièce de rechange

W = Pièce d'usure

NA = Non disponible

Les kits de pièces détachées contiennent toute la visserie et les composants s'y rapportant.

La visserie est un composant d'assemblage standard, que vous pouvez facilement trouver chez tous les détaillants de composants d'assemblage standards.

Tous les composants d'assemblage standard sont d'une classe de qualité 8.8.

Nous recommandons de ne pas utiliser une classe de qualité inférieure à 8.8 pour tous les composants d'assemblage standards.

Pour les pièces non standard, les pièces de remplacement doivent impérativement provenir de Norton CLIPPER.

La durée de vie des pièces d'usure varie en fonction de l'utilisation et de la maintenance de la machine ou de la pièce. Les pièces d'usure devront être entretenues et remplacées au besoin. Aucune garantie n'est appliquée aux pièces d'usure.

Les composants NA (Not Available) ne sont pas disponibles en pièce de rechange.

DEUTSCH

TYP :

S = Ersatzteile

W = Verschleißteile

NA = nicht verfügbare

Die definierten Ersatzteil-Set's beinhalten alle Ersatzteile wie Komponenten, Schrauben, Muttern etc.

Norm- bzw. Standardteile wie Schrauben, Muttern etc. können bei offiziellen Schrauben- sowie Komponentenhändler bezogen werden.

Alle Norm- bzw. Standardteile wie Schrauben, Muttern etc. entsprechen der Qualitäts- bzw. Festigungsklasse 8.8.

Wir empfehlen, keine Norm- bzw. Standardteile wie Schrauben, Muttern etc. unter der Qualitäts- bzw.

Festigungsklasse 8.8 einzusetzen.

Es dürfen nur geprüfte Norton CLIPPER-Ersatzteile eingesetzt werden.

Die Lebensdauer der Verschleißteile hängt von der Verwendung und Wartung der Maschine oder des Teils ab. Verschleißteile müssen gewartet und bei Bedarf ersetzt werden. Für Verschleißteile wird keine Garantie übernommen.

Ersatzteile sowie Komponenten mit dem Vermerk NA (NA=nicht verfügbar) sind nicht verfügbar.

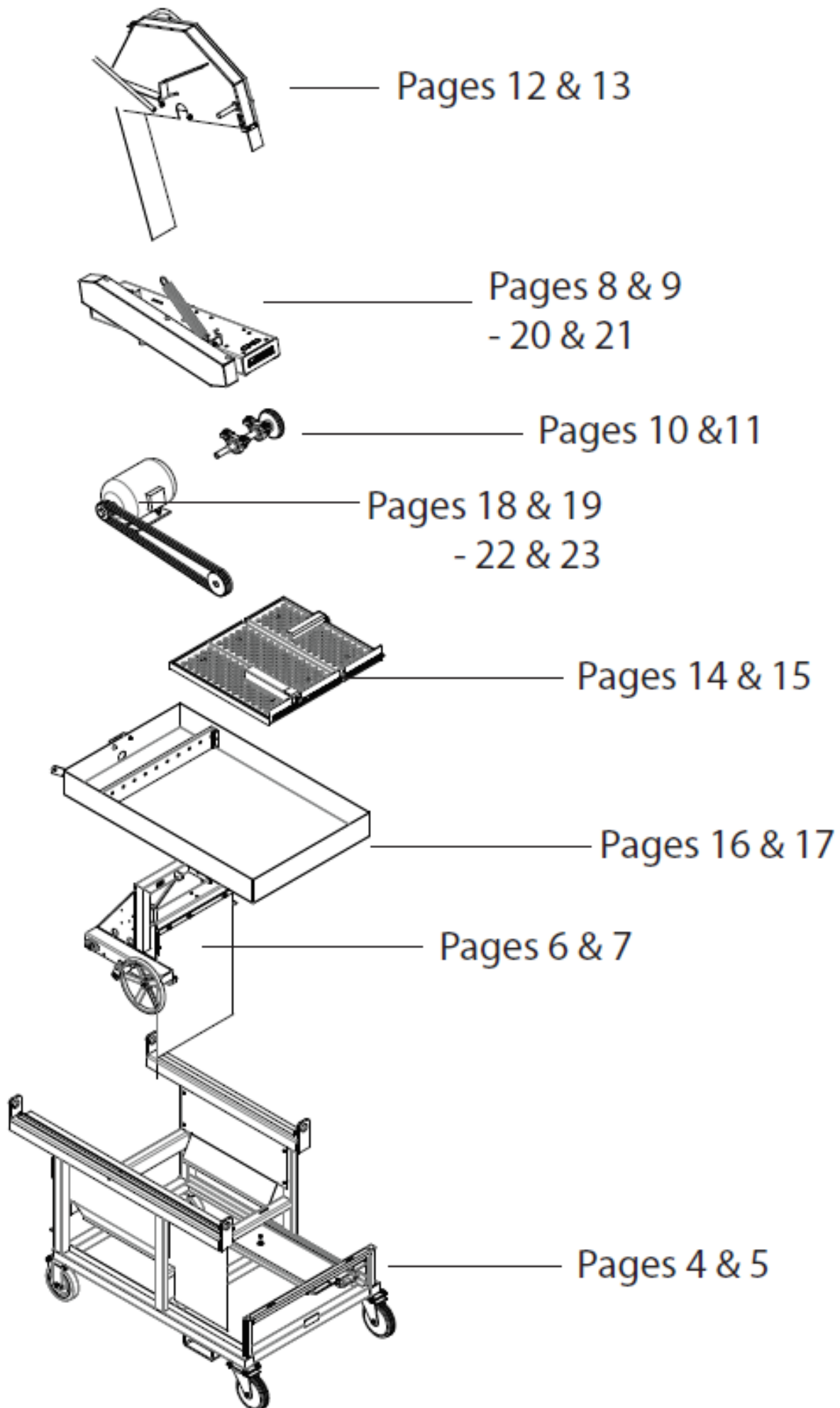

Main frame / Châssis principal / Rahmen

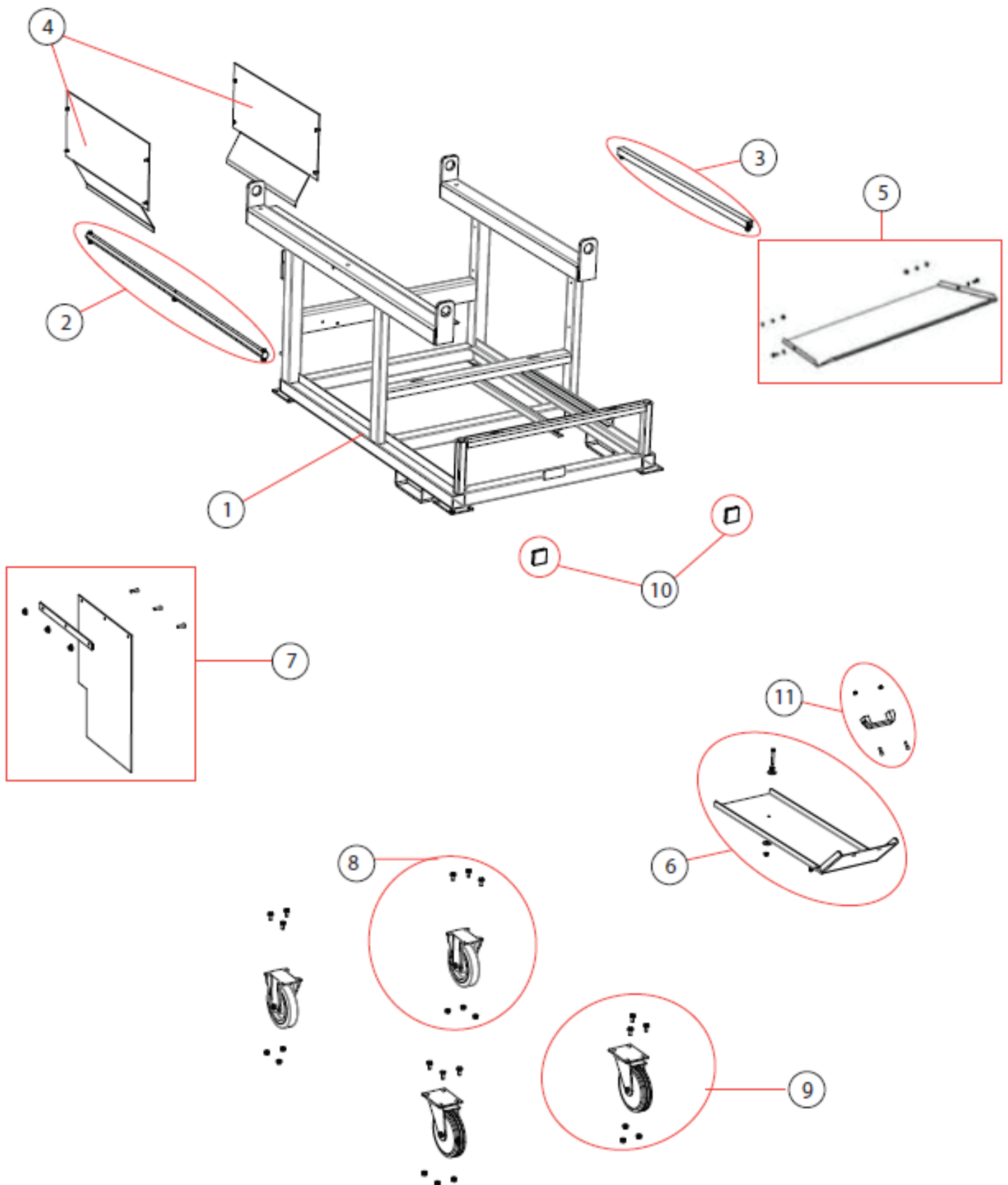

POS.	DESCRIPTION	DESCRIPTION	BESCHREIBUNG	QTY	REF	TYPE
1	Frame	Châssis	Rahmen	1	310005355	S
2	Guiding rail left assy.	Rail gauche (hexago)	Links Schiene (sechseckig)	1	310005356	S
	Guiding rail left assy.	Rail gauche (hexago)	Link Schiene (sechseckig)	1		
	screw DIN 931 – M8X50	vis DIN 931 – M8X50	Schraube DIN 931 – M8X50	2		
	screw DIN 933 – M8X35	vis DIN 933 – M8X35	Schraube DIN 933 – M8X35	1		
	washer DIN 125 - Ø8,4 Z	rondelle DIN 125 - Ø8,4 Z	Scheibe DIN 125 - Ø8,4 Z	2		
	washer DIN 127 - W8	rondelle DIN 127 - W8	Scheibe DIN 127 - W8	3		
	washer DIN 125 - Ø8,4 M	rondelle DIN 125 - Ø8,4 M	Scheibe DIN 125 - Ø8,4 M	3		
	nut DIN 934 - M8	ecrou DIN 934 - M8	Mutter DIN 934 - M8	2		
3	Guiding rail right assy.	Rail droit complet	Rechts Schiene, kompl.	1	310005357	S
	Guiding rail right assy.	Rail droit	Rechts Schiene	1		
	screw DIN 912 – M8X20	vis DIN 912 – M8X20	Schraube DIN 912 – M8X20	2		
	washer DIN 125 - Ø8,4 Z	rondelle DIN 125 - Ø8,4 Z	Scheibe DIN 125 - Ø8,4 Z	2		
	washer DIN 125 - Ø8,4 M	rondelle DIN 125 - Ø8,4 M	Scheibe DIN 125 - Ø8,4 M	2		
	washer DIN 127 - W8	rondelle DIN 127 - W8	Scheibe DIN 127 - W8	2		
	nut DIN 985 - M8	ecrou DIN 985 - M8	Mutter DIN 985 - M8	2		
4	Side curtain assy.	Tôle protection latérale complète	Seitenschutzblech, kompl.	1	310004998	S
	Side curtain	Tôle protection latérale	Seitenschutzblech	2		
	screw DIN 933 – M8X20	vis DIN 933 – M8X20	Schraube DIN 933 – M8X20	4		
	washer DIN 125 - Ø8,4	rondelle DIN 125 - Ø8,4	Scheibe DIN 125 - Ø8,4	4		
	washer DIN 127 - W8	rondelle DIN 127 - W8	Scheibe DIN 127 - W8	4		
5	Water collector assy. (serial number up to 130400056)	Tôle de récupération d'eau complète (n° de série jusqu'à 130400056)	Wassersammlungsblech, kompl. (Serien Nr. bis 130400056)	1	310005272	S
	Slide front protection	Tiroir de protection	Schutzschubkasten	1		
	screw DIN 933 M8x55	vis DIN933 M8x50	Schraube DIN933 M8x50	1		
	nut DIN934 M8	ecrou DIN934 M8	Mutter DIN934 M8	2		
6	Slide front protection (serial number from 130400056)	Tiroir de protection avant (n° de série à partir de 130400056)	Vorderschutzschubkasten (Serien Nr. von 130400056)	1	510107910	S
	Water collector	Tôle de récupération d'eau	Wassersammlungsblech	1		
	screw DIN 933 – M8X20	vis DIN 933 – M8X20	Schraube DIN 933 – M8X20	2		
	nut DIN 934 - M8	ecrou DIN 934 - M8	Mutter DIN 934 - M8	2		
	Handle	Poignée	Griff	1		
	washer DIN 125 - A6,4	rondelle DIN 125 - A6,4	Scheibe DIN 125 - A6,4	2		
	screw DIN 912 - M6x20	vis DIN 912 - M6x20	Schraube DIN 912 - M6x20	2		
	washer DIN 127 - A6	rondelle DIN 127 - A6	Scheibe DIN 127 - A6	2		
	nut DIN 934 - M6	ecrou DIN 934 - M6	Mutter DIN 934 - M6	2		
7	Lateral splash guard assy.	Bavette latérale complète	Vollständige Seitenlandeklappe	1	310004501	S
	Lateral splash guard	Bavette latérale	Seitenspritzklappe	1		
	Holding plate	Plaque de maintien	Aufrechterhaltungsplatte	1		
	screw DIN 933 – M8X20	vis DIN 933 – M8X20	Schraube DIN 933 – M8X20	3		
	washer DIN 125 - Ø8,4 M	rondelle DIN 125 - Ø8,4 M	Scheibe DIN 125 - Ø8,4 M	3		
	nut DIN 985 - M8	ecrou DIN 985 - M8	Mutter DIN 985 - M8	3		
8	Rear wheels	Kit Roue arrière	Hinterrad Satz	1	510103416	S
	Rear wheel	Roue arrière	Hinterrad	1		
	screw DIN 933 – M10X25	vis DIN 933 – M10X25	Schraube DIN 933 – M10X25	3		
	washer DIN 125 - Ø10,5	rondelle DIN 125 - Ø10,5	Scheibe DIN 125 - Ø10,5	6		
	washer DIN 127 - W10	rondelle DIN 127 - W10	Scheibe DIN 127 - W10	3		
	nut DIN 985 - M10	ecrou DIN 985 - M10	Mutter DIN 985 - M10	3		
9	Front wheels	Kit Roue avant	Vorderrad Satz	1	510103417	S
	Front wheel	Roue avant	Vorderrad	1		
	screw DIN 933 – M10X25	vis DIN 933 – M10X25	Schraube DIN 933 – M10X25	3		
	washer DIN 125 - Ø10,5	rondelle DIN 125 - Ø10,5	Scheibe DIN 125 - Ø10,5	6		
	washer DIN 127 - W10	rondelle DIN 127 - W10	Scheibe DIN 127 - W10	3		
	nut DIN 985 - M10	ecrou DIN 985 - M10	Mutter DIN 985 - M10	3		
10	Square tube cap (set of 6 large)	Bouchon tube (jeu de 6)	Rohrdeckel (Satz von 6 Stk)	1	510103418	S
	Tube cap 60x60	Bouchon tube 60x60	Rohrdeckel 60x60	4		
	Tube cap 40x40	Bouchon tube 40x40	Rohrdeckel 40x40	2		
11	Handle	Kit poignée	Griff Satz	1	310007042	S
	Handle	Poignée	Griff	1		
	washer DIN 125 - A6,4	rondelle DIN 125 - A6,4	Scheibe DIN 125 - A6,4	2		
	screw DIN 912 - M6x15	vis DIN 912 - M6x15	Schraube DIN 912 - M6x15	2		
	washer DIN 127 - A6	rondelle DIN 127 - A6	Scheibe DIN 127 - A6	2		
	nut DIN 985 - M6	ecrou DIN 985 - M6	Mutter DIN 985 - M6	2		

Carriage / Chariot / Wagen

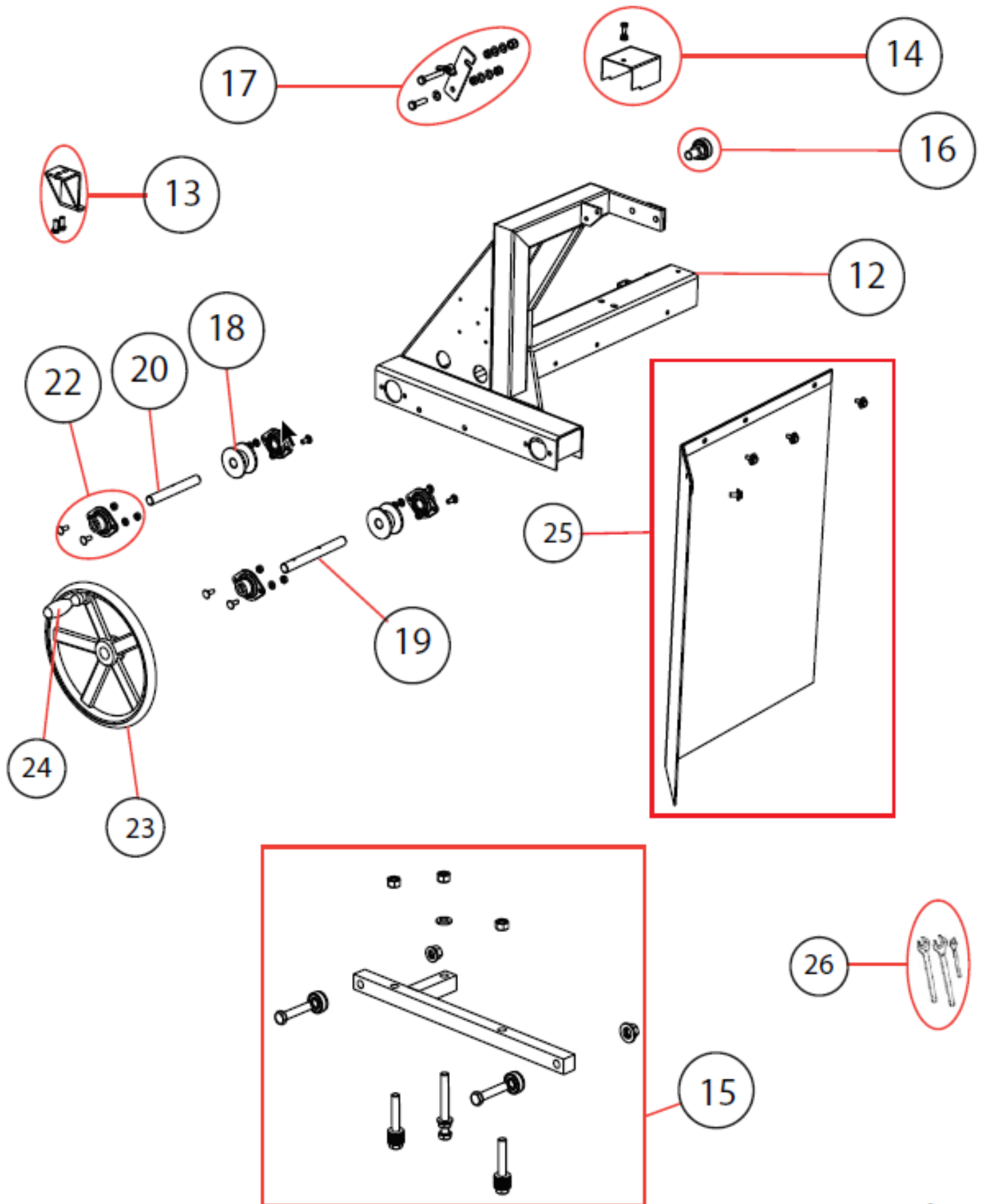

POS.	DESCRIPTION	DESCRIPTION	BESCHREIBUNG	QTY	REF	TYPE
12	Conveyor cart kit	Kit chariot	Wagen Satz	1	310005358	S
	Conveyor cart	Chariot	Wagen	1		
13	Securing axle	Butée anti bascule	Stabilisierung Anschlag	1	310005285	S
	Securing axle	Butée anti bascule	Kippsichere Anschlag	1		
	screw DIN 933 - M8X20	vis DIN 933 - M8X20	Schraube DIN 933 - M8X20	1		
	washer DIN 125 - Ø8,4	rondelle DIN 125 - Ø8,4	Scheibe DIN 125 - Ø8,4	1		
	washer DIN 127 - W8	rondelle DIN 127 - W8	Scheibe DIN 127 - W8	1		
14	Sheet of protection	Tôle de protection	Schutzblech	1	310005032	S
	Sheet of protection	Tôle de protection	Schutzblech	1		
	screw DIN 933 - M10X25	vis DIN 933 - M10X25	Schraube DIN 933 - M10X25	2		
	washer DIN 125 - Ø10,5 "L"	rondelle DIN 125 - Ø10,5 "L"	Scheibe DIN 125 - Ø10,5 "L"	2		
	washer DIN 127 - W10	rondelle DIN 127 - W10	Scheibe DIN 127 - W10	2		
15	Back stop of conveyor cart assy.	Butée de chariot complète	Wagen Anschlag, kompl.	1	510103420	S
	Back stop of conveyor	Butée de chariot	Wagen Anschlag	1		
	screw DIN 933 - M12X100	vis DIN 933 - M12X100	Schraube DIN 933 - M12X100	3		
	washer DIN 2093 - Ø12	rondelle DIN 2093 - Ø12	Scheibe DIN 2093 - Ø12	20		
	nut DIN 934 - M12	ecrou DIN 934 - M12	Mutter DIN 934 - M12	4		
	nut DIN 985 - M12	ecrou DIN 985 - M12	Mutter DIN 985 - M12	2		
	screw DIN 933 - M12X60	vis DIN 933 - M12X60	Schraube DIN 933 - M12X60	2		
	washer DIN 127 - W12	rondelle DIN 127 - W12	Scheibe DIN 127 - W12	8		
	Wheel	Roulette	Lenkrolle	2		
16	Wheel right assy.	Roulette droite complète	Rechtlenkrolle, kompl.	1	310002238	S
	Wheel	Roulette	Lenkrolle	1		
	Eccentric axis	Axe excentrique	Exzentrische Achse	1		
	nut DIN 934 - M20	ecrou DIN 934 - M20	Mutter DIN 934 - M20	1		
	Circlips Ø18,5	Circlips Ø18,5	Sicherungsring Ø18,5	1		
17	Locking conveyor cart assy.	Blocage chariot complet	Wagen Blockierung, kompl.	1	310005359	S
	Sheet of blocking	Tôle de blocage	Blockierungsblech	1		
	screw DIN 933 - M10X35	vis DIN 933 - M10X35	Schraube DIN 933 - M10X35	1		
	washer DIN 125 - Ø10,5	rondelle DIN 125 - Ø10,5	Scheibe DIN 125 - Ø10,5	7		
	nut DIN 985 - M10	ecrou DIN 985 - M10	Mutter DIN 985 - M10	2		
	nut DIN 934 - M10	ecrou DIN 934 - M10	Mutter DIN 934 - M10	2		
	screw DIN 933 - M10X65	vis DIN 933 - M10X65	Schraube DIN 933 - M10X65	1		
	nut DIN 315 - M10	ecrou DIN 315 - M10	Mutter DIN 315 - M10	1		
18	Table roller	Roulette	Lenkrolle	1	310005281	S
19	Arbor, handwheel	Axe volant	Steuerrad Achse	1	310005282	S
20	Arbor, back-wheel	Axe roulette arrière	Hinterrad Achse	1	310005283	S
22	Flange bearing	Palier	Lager	1	510128476	S
	Flange bearing	Palier	Lager	1		
	screw DIN 603 - M8X20	vis DIN 603 - M8X20	Schraube DIN 603 - M8X20	2		
	washer DIN 127 - B8	rondelle DIN 127 - B8	Scheibe DIN 127 - B8	2		
	washer DIN 125 - Ø8,4	rondelle DIN 125 - Ø8,4	Scheibe DIN 125 - Ø8,4	2		
	nut DIN 985 - M8	ecrou DIN 985 - M8	Mutter DIN 985 - M8	2		
23	Handwheel	Volant	Steuerrad	1	310005279	S
	Handwheel	Volant	Steuerrad	1		
	Pin	Goupille	Stift	1		
24	Handgrip	Poignée volant	Steuerrad Griff	1	310005280	S
25	Rear splash guard assy.	Bavette arrière complète	Hintererspritzlappen kompl.	1	310004502	S
	Rear splash guard	Bavette arrière	Hintere Spritzlappen	1		
	Holding plate	Plaque de maintien	Trägerplatte	1		
	Screw DIN 933 - M8x20	Vis DIN 933 - M8x20	Scheibe DIN 9021 - A8	3		
	Washer DIN 9021 - A8	Rondelle DIN 9021 - A8	Scheibe DIN 9021 -	3		
	Washer DIN 127 - W8	Rondelle DIN 127 - W8	Scheibe DIN 127 - W8	3		
26	Wrench kit	Kit clé	Maulschlüssel Satz	1	510107908	S
	Wrench 36mm	Clé 36mm	Maulschlüssel 36mm	2		
	Wrench 13mm	Clé 13mm	Maulschlüssel 13mm	1		

Cutting head / Tête de coupe / Schüsselkopf

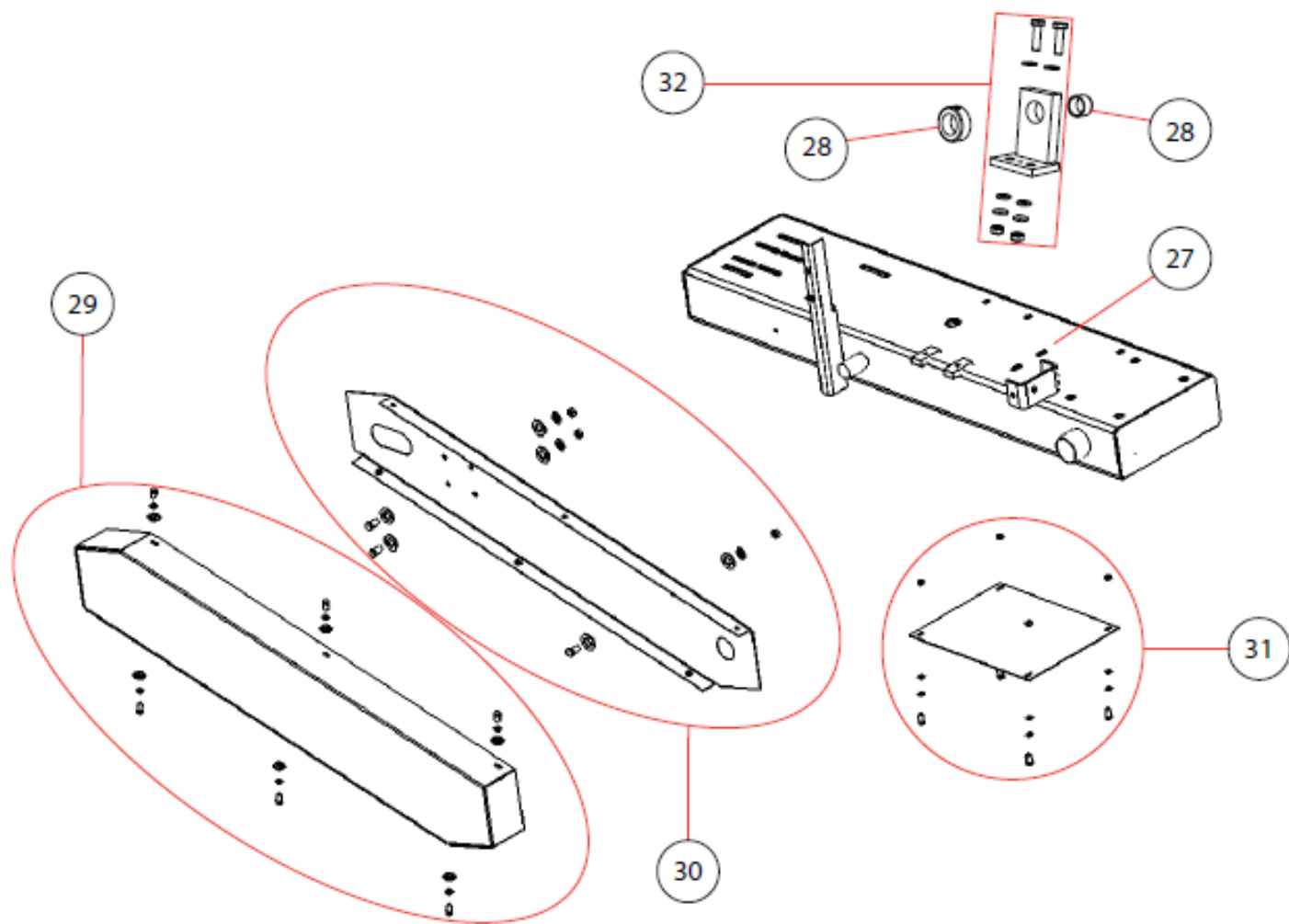

POS.	DESCRIPTION	DESCRIPTION	BESCHREIBUNG	QTY	REF	
27	Cutting head kit	Kit tête de coupe	Schneidkopf Satz	1	310005363	S
	Cutting head	Tête de coupe	Schneidkopf	1		
28	Locking ring + bearing	Bague d'arrêt + palier	Anschlagsring + Lager	1	310002246	S
	Locking ring DIN 705 - Ø28	Bague d'arrêt DIN 705 - Ø28	Anschlagsring DIN 705 - Ø28	2		
	IGLIDUR Ring GSM 283220	Bague IGLIDUR GSM 283220	Ring IGLIDUR GSM 283220	2		
29	Mobile belt guard	Carter mobile de courroies	Bewegliches Riemengehäuse	1	310005360	S
	Mobile belt guard	Carter mobile	Bewegliches Gehäuse	1		
	screw DIN 933 – M6X16	vis DIN 933 – M6X16	Schraube DIN 933 – M6X16	6		
	washer DIN 125 - Ø6,3	rondelle DIN 125 - Ø6,3	Scheibe DIN 125 - Ø6,3	6		
	washer DIN 127 - W6	rondelle DIN 127 - W6	Scheibe DIN 127 - W6	6		
30	Fixed belt guard	Carter fixe de courroies	Festes Riemengehäuse	1	310005361	S
	Fixed belt guard	Carter Fixe	Festes Gehäuse	1		
	screw DIN 933 – M8X20	vis DIN 933 – M8X20	Schraube DIN 933 – M8X20	3		
	washer DIN 125 - Ø8,4	rondelle DIN 125 - Ø8,4	Scheibe DIN 125 - Ø8,4	6		
	washer DIN 127 - W8	rondelle DIN 127 - W8	Scheibe DIN 127 - W8	3		
	nut DIN 934 - M8	ecrou DIN 934 - M8	Mutter DIN 934 - M8	3		
31	Protector plate of blade shaft	Tôle de protection arbre de meule	Schutzblech des Schleifscheibenachse	1	310005290	S
	Protector plate of blade shaft	Tôle de protection arbre de meule	Schutzblech des Schleifscheibenachse	1		
	screw DIN 933 – M6X16	vis DIN 933 – M6X16	Schraube DIN 933 – M6X16	4		
	washer DIN 125 - Ø6,3	rondelle DIN 125 - Ø6,3	Scheibe DIN 125 - Ø6,3	4		
	washer DIN 127 - W6	rondelle DIN 127 - W6	Scheibe DIN 127 - W6	4		
32	Mobile Pivoting system assy.	Chape mobile complète	Bewegbaren Träger, kompl.	1	310005362	S
	Mobile Pivoting system	Chape mobile	bewegbaren Träger	1		
	screw DIN 933 – M10X35	vis DIN 933 – M10X35	Schraube DIN 933 – M10X35	2		
	washer DIN 9021 - Ø10,5	rondelle DIN 9021 - Ø10,5	Scheibe DIN 9021 - Ø10,5	4		
	washer DIN 127 - W10	rondelle DIN 127 - W10	Scheibe DIN 127 - W10	2		
	nut DIN 985 - M10	ecrou DIN 985 - M10	Mutter DIN 985 - M10	2		
	Spring pins DIN 1481 - 6X30	Goupilles élastiques DIN 1481 - 6X30	elastische Stifte DIN 1481 - 6X30	1		

Blade shaft / Arbre de meule / Mühlsteinbaum

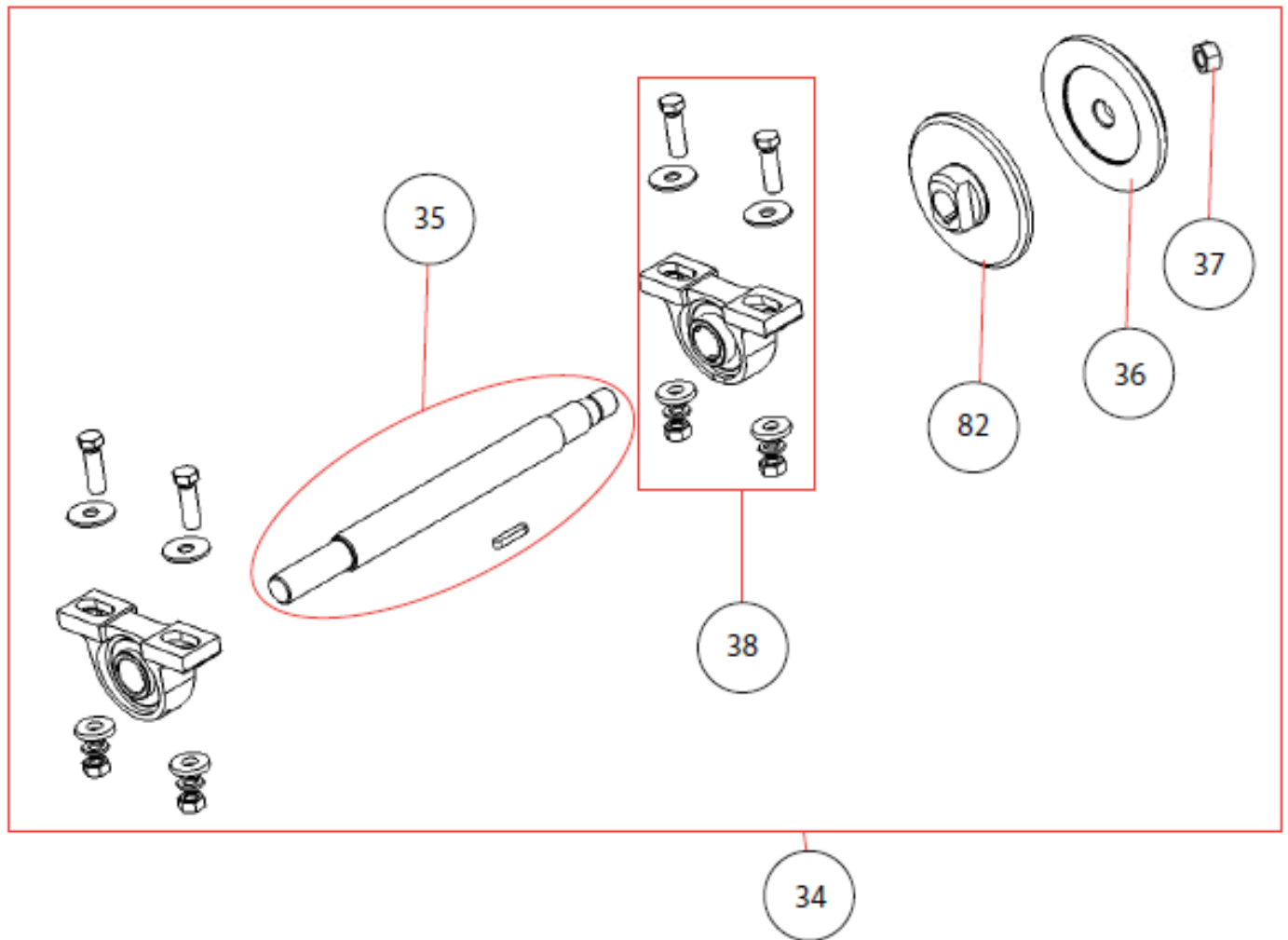

POS.	DESCRIPTION	DESCRIPTION	BESCHREIBUNG	QTY	REF	TYPE
34	Blade shaft	Kit arbre de meule prémonté	Vormontierte Schleifscheibenachse Satz	1	510112651	S
	Blade shaft	Arbre de meule	Schleifscheibenachse	1		
	Fixed flange	Flasque fixe	Festes Lagerschild	1		
	Mobile flange	Flasque mobile	Bewegliches Lagerschild	1		
	Key DIN 6885 - A8x7x40	Clavette DIN 6885 - A8x7x40	Keil DIN 6885 - A8x7x40	1		
	nut	ecrou	Mutter	1		
	Blade shaft bearing	Palier arbre de meule	Schleifscheibenachse Lager	2		
	screw DIN 933 – M14X50	vis DIN 933 – M14X50	Schraube DIN 933 – M14X50	4		
	washer DIN 9021 - Ø15	rondelle DIN 9021 - Ø15	Scheibe DIN 9021 - Ø15	4		
	washer DIN 125 - Ø15	rondelle DIN 125 - Ø15	Scheibe DIN 125 - Ø15	4		
	washer DIN 127 - W14	rondelle DIN 127 - W14	Scheibe DIN 127 - W14	4		
	nut DIN 934 - M14	ecrou DIN 934 - M14	Mutter DIN 934 - M14	4		
	Spring pins DIN 1481 - 6X30	Goupilles élastiques DIN 1481 - 6X30	elastische Stifte DIN 1481 - 6X30	2		
35	Blade shaft kit	Kit arbre de meule	Schleifscheibenachse Satz	1	310005364	S
	Blade shaft	Arbre de meule	Schleifscheibenachse	1		
	Key DIN 6885 - A8x7x40	Clavette DIN 6885 - A8x7x40	Keil DIN 6885 - A8x7x40	1		
36	Mobile flange	Flasque mobile	Bewegliches Lagerschild	1	310005050	S
82	Fixed flange	Flasque fixe	Festes Lagerschild	1	310005294	S
37	nut	ecrou	Mutter	1	310005048	S
38	Blade shaft bearing kit	Kit palier arbre de meule	Schleifscheibenachse Satz	1	310005293	S
	Blade shaft bearing	Palier arbre de meule	Schleifscheibenachse Lager	1		
	screw DIN 933 – M14X50	vis DIN 933 – M14X50	Schraube DIN 933 – M14X50	2		
	washer DIN 9021 - Ø15	rondelle DIN 9021 - Ø15	Scheibe DIN 9021 - Ø15	2		
	washer DIN 125 - Ø15	rondelle DIN 125 - Ø15	Scheibe DIN 125 - Ø15	2		
	washer DIN 127 - W14	rondelle DIN 127 - W14	Scheibe DIN 127 - W14	2		
	nut DIN 934 - M14	ecrou DIN 934 - M14	Mutter DIN 934 - M14	2		
	Spring pins DIN 1481 - 6X30	Goupilles élastiques DIN 1481 - 6X30	Elastische Stifte DIN 1481 - 6X30	1		

Blade guard / Carter de disque / Plattegehäuse

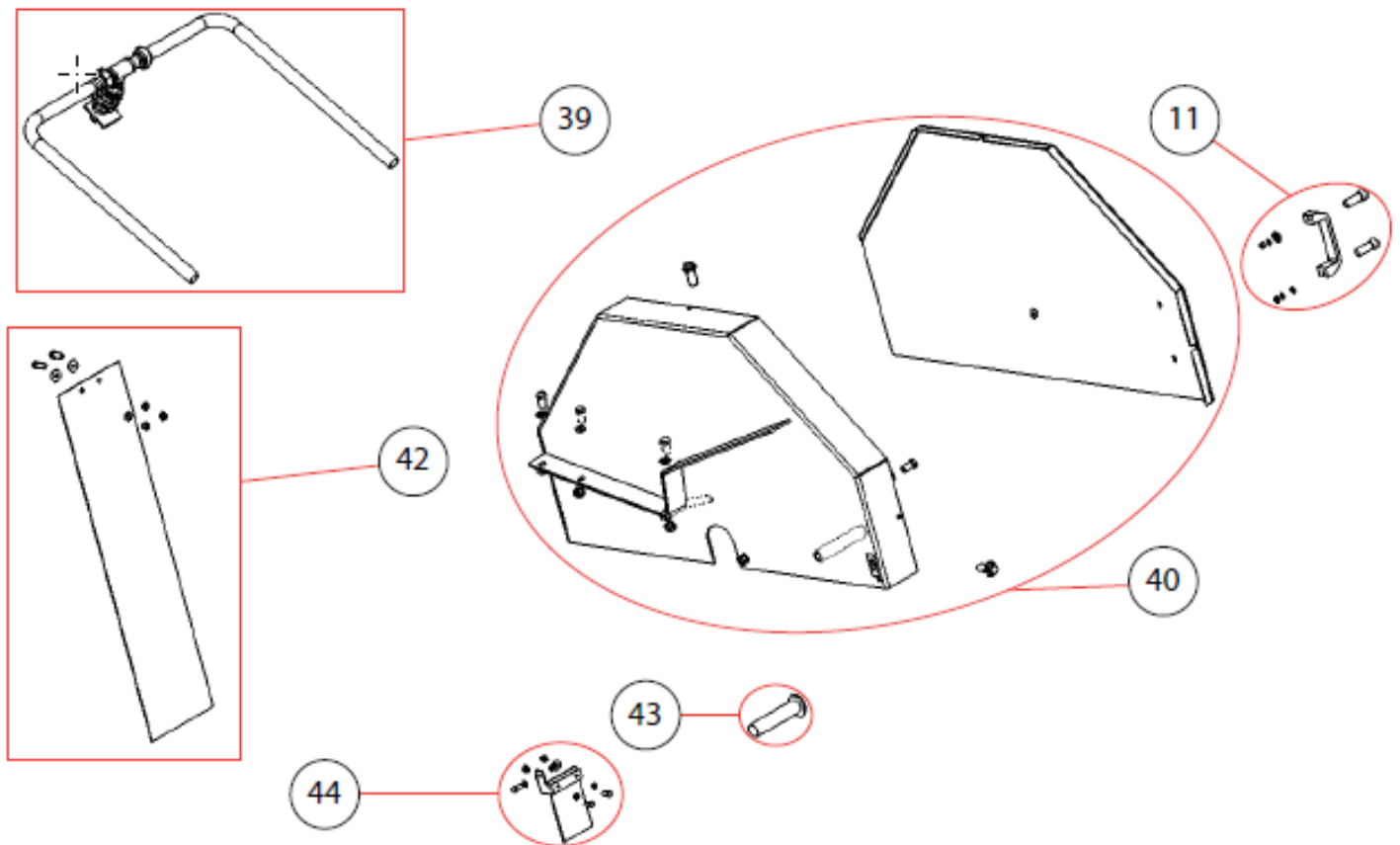

POS.	DESCRIPTION	DESCRIPTION	BESCHREIBUNG	QTY	REF	TYPE
11	Handle	Kit poignée	Griff	1	310007042	S
	Handle	Poignée	Griff	1		
	washer DIN 125 - A6,4	rondelle DIN 125 - A6,4	Scheibe DIN 125 - A6,4	2		
	screw DIN 912 - M6x15	vis DIN 912 - M6x15	Schraube DIN 912 - M6x15	2		
	washer DIN 127 - A6	rondelle DIN 127 - A6	Scheibe DIN 127 - A6	2		
	nut DIN 985 - M6	ecrou DIN 985 - M6	Mutter DIN 985 - M6	2		
39	Watering system assy.	Système d'arrosage complet	Wässersystem, kompl.	1	310005367	S
	Watering system	Système d'arrosage	Bewässerungssystem	1		
	Double brass nipples	Raccord tuyau	Rohrverbindung	1		
	Watering nozzle	Busette	Düse	2		
	Brass quick coupling	Raccord rapide	Schnellkupplung	1		
	Faucet	Robinet à boisseau	Kugelventil	1		
	T fitting	Raccord en T	T-Verbinder	1		
40	Blade guard (Fixed + Mobile) J900	Carter (Fixe + Mobile) J900	(Festes + Bewegliches) J 900 Gehäuse	1	310495680	S
	Blade guard (Fixed + Mobile) J1000	Carter (Fixe + Mobile) J1000	(Festes + Bewegliches) J1000 Gehäuse	1	310495681	S
	Mobile blade guard	Carter mobile	Bewegliches Gehäuse	1		
	Fixed blade guard	Carter fixe	Festes Gehäuse	1		
	screw DIN 933 - M8X30	vis DIN 933 - M8X30	Schraube DIN 933 - M8X30	2		
	screw DIN 933 - M10X30	vis DIN 933 - M10X30	Schraube DIN 933 - M10X30	6		
	washer DIN 125 - Ø10,5	rondelle DIN 125 - Ø10,5	Scheibe DIN 125 - Ø10,5	12		
	washer DIN 127 - W10	rondelle DIN 127 - W10	Scheibe DIN 127 - W10	6		
	nut DIN 985 - M10	ecrou DIN 985 - M10	Mutter DIN 985 - M10	6		
	nut DIN985 - M8	ecrou DIN985 - M8	Mutter DIN985 - M8	2		
42	Splash guard assy.	Bavette complète	Spritzlappen, kompl.	1	310005302	S
	Splash guard	Bavette	Spritzlappen	1		
	screw DIN 933 - M8X20	vis DIN 933 - M8X20	Schraube DIN 933 - M8X20	2		
	washer DIN 9021 - Ø8,4	rondelle DIN 9021 - Ø8,4	Scheibe DIN 9021 - Ø8,4	2		
	nut DIN 985 - M8	ecrou DIN 985 - M8	Mutter DIN 985 - M8	2		
43	Rubber handle	Poignée en caoutchouc	Gummigriff	1	310004190	S
44	Front splash guard assy.	Bavette avant complète	Vodersespritzlappen, kompl.	1	510107909	S
	Splash guard	Bavette	Spritzlappen	1		
	Support plate	Plaque de support	Trägerplatte	1		
	screw DIN 933 - M6x12	vis DIN 933 - M6x12	Schraube DIN 933 - M6x12	3		
	washer DIN 125 - A6,4	rondelle DIN 125 - A6,4	Scheibe DIN 125 - A6,4	3		
	nut DIN 985 - M6	ecrou DIN 985 - M6	Mutter DIN 985 - M6	3		

Table / Table / Tisch

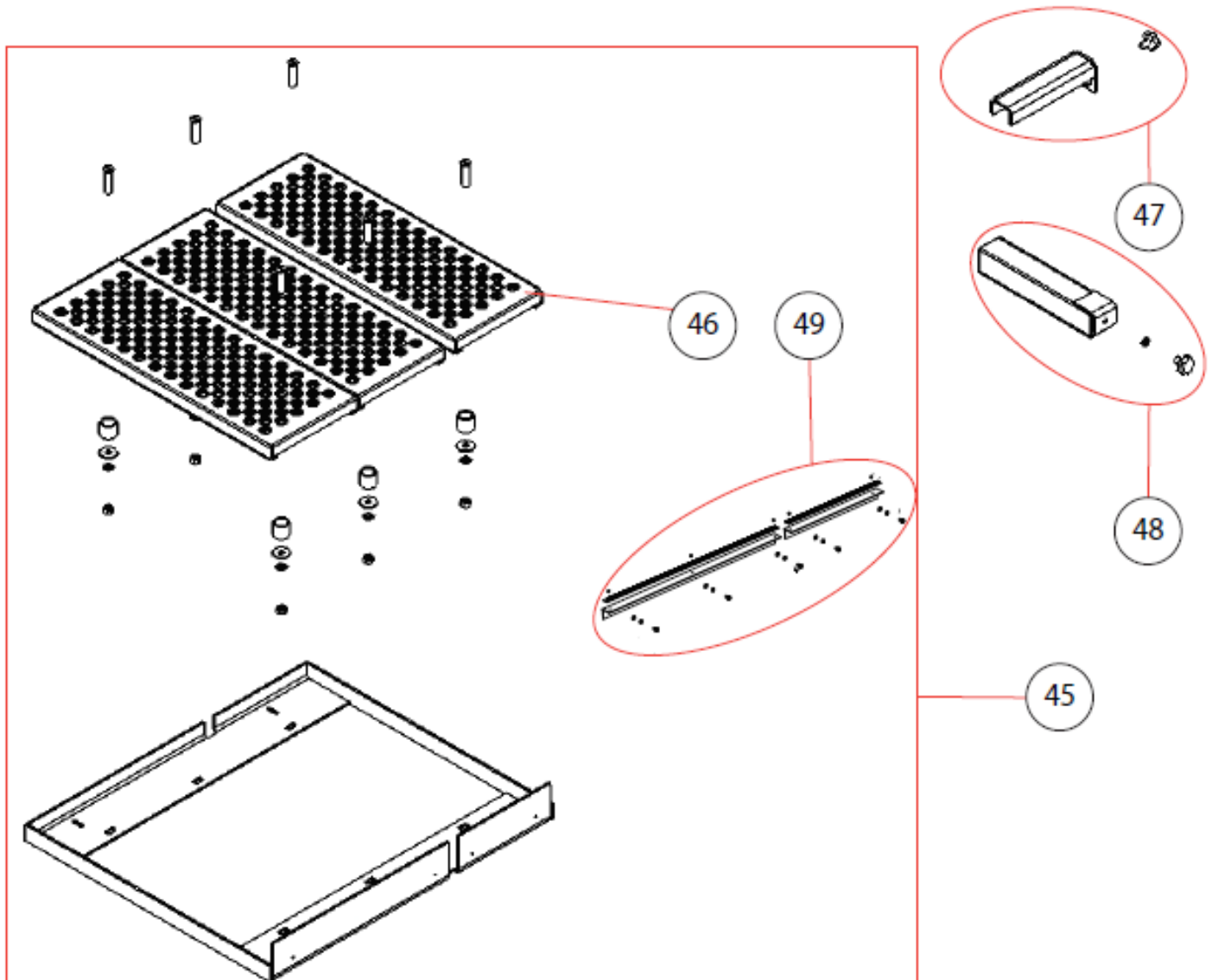

POS.	DESCRIPTION	DESCRIPTION	BESCHREIBUNG	QTY	REF	TYPE
45	Table assy	Table complete	Tisch, kompl.	1	310484310	S
	Table frame	Châssis table	Tisch Rahmen	1		
	screw DIN 933 – M8X35	vis DIN 933 – M8X35	Schraube DIN 933 – M8X35	6		
	washer DIN 9021 - Ø8,4	rondelle DIN 9021 - Ø8,4	Scheibe DIN 9021 - Ø8,4	18		
	washer DIN 127 - W8	rondelle DIN 127 - W8	Scheibe DIN 127 - W8	6		
	nut DIN 934 - M8	ecrou DIN 985 - M8	Mutter DIN 985 - M8	6		
	Lath floor table	Caillebotis	Gitterrost	3		
	screw DIN 963 – M10X60	vis DIN 963 – M10X60	Schraube DIN 963 – M10X60	6		
	washer DIN 125 - Ø10,5 M	rondelle DIN 125 - Ø10,5 M	Scheibe DIN 125 - Ø10,5 M	6		
	washer DIN 127 - W10	rondelle DIN 127 - W10	Scheibe DIN 127 - W10	6		
	nut DIN 934 - M10	ecrou DIN 934 - M10	Mutter DIN 934 - M10	6		
	Spacer 28x34x34	Entretoise 28x34x34	Strebe 28x34x34	1		
	Ruler	Reglette	Leiste	2		
	screw DIN 933 -M4x10	vis DIN 933 -M4x10	Schraube DIN 933 -M4x10	5		
	washer DIN125 - A4,3	rondelle DIN125 - A4,3	Scheibe DIN125 - A4,3	5		
	washer DIN127 - A4	rondelle DIN127 - A4	Scheibe DIN127 - A4	5		
46	Lath floor table	Caillebotis table complet	Gitterrost Tisch, kompl.	1	310005488	S
	Lath floor table	Caillebotis table	Gitterrost Tisch	1		
	screw DIN 963 – M10X60	vis DIN 963 – M10X60	Schraube DIN 963 – M10X60	2		
	washer DIN 125 - Ø10,5	rondelle DIN 125 - Ø10,5	Scheibe DIN 125 - Ø10,5	2		
	washer DIN 127 - W10	rondelle DIN 127 - W10	Scheibe DIN 127 - W10	2		
	nut DIN 934 - M10	ecrou DIN 934 - M10	Mutter DIN 934 - M10	2		
	Spacer 28x34x34	Entretoise 28x34x34	Strebe 28x34x34	2		
47	Back stop	Butée de matériau complet	Verschiebungsanschlag, kompl.	1	310005304	S
	knob M10x10	molette M10x10	Knopf M10x10			
48	Cutting guide	Guide de coupe complet	Schneideführung, kompl.	1	310005303	S
	knob M10x10	molette M10x10	Knopf M10x10			
49	Scale complete	Réglette complète	Leiste Kompl	1	510103445	S
	Scale	Réglette	Leiste	2		
	screw DIN 933 -M4x10	vis DIN 933 -M4x10	Schraube DIN 933 -M4x10	5		
	washer DIN125 - A4,3	rondelle DIN125 - A4,3	Scheibe DIN125 - A4,3	5		
	washer DIN127 - A4	rondelle DIN127 - A4	Scheibe DIN127 - A4	5		

Water tray / Bac à eau / Behälter an Wasser

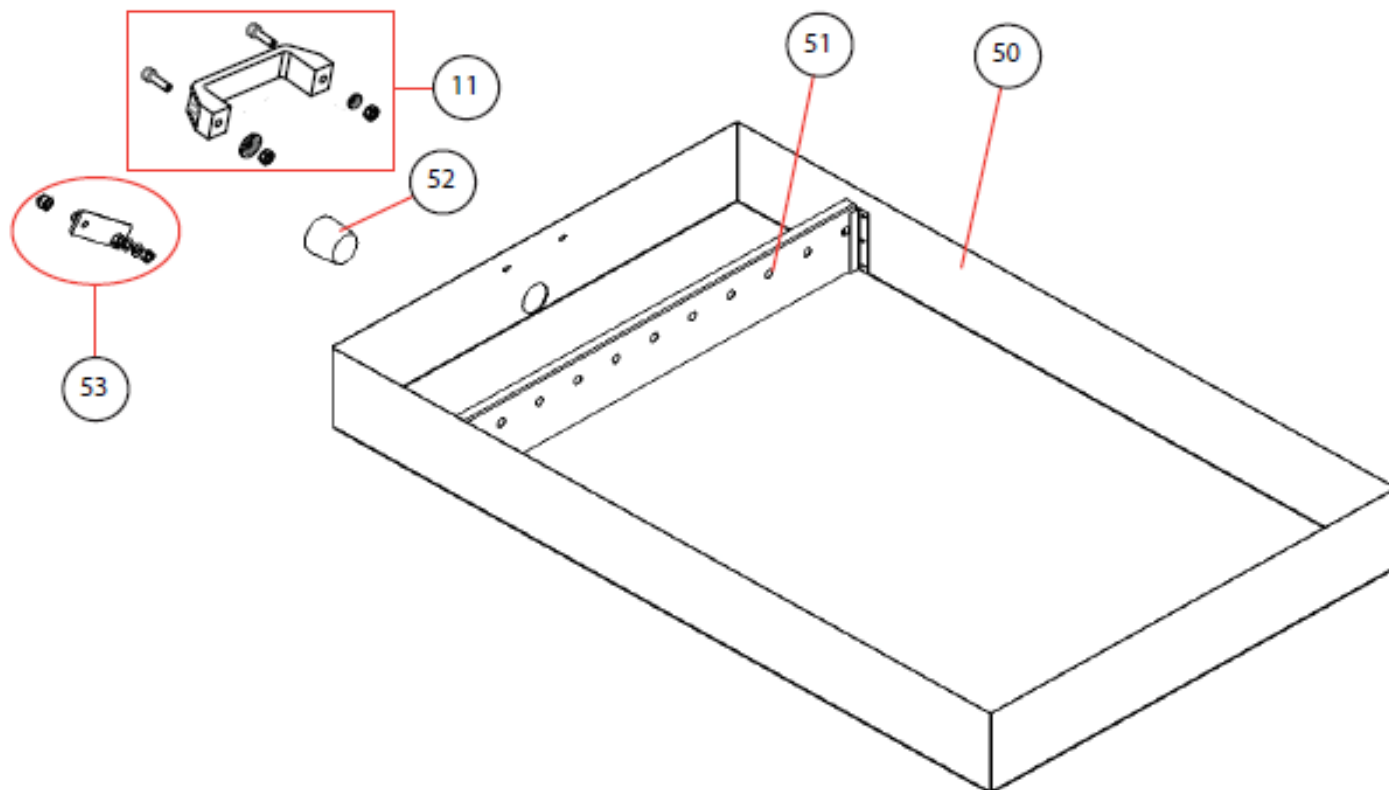

POS.	DESCRIPTION	DESCRIPTION	BESCHREIBUNG	QTY	REF	TYPE
11	Handle	Kit poignée	Griff	1	310007042	S
	Handle	Poignée	Griff	1		
	washer DIN 125 - A6,4	rondelle DIN 125 - A6,4	Scheibe DIN 125 - A6,4	2		
	screw DIN 912 - M6x15	vis DIN 912 - M6x15	Schraube DIN 912 - M6x15	2		
	washer DIN 127 - A6	rondelle DIN 127 - A6	Scheibe DIN 127 - A6	2		
	nut DIN 985 - M6	ecrou DIN 985 - M6	Mutter DIN 985 - M6	2		
50	Water tray assy	Bac à eau complet	Wasserbehälter, kompl.	1	310005001	S
	Water tray	Bac à eau	Wasserbehälter	1		
	screw DIN 933 - M10X30	vis DIN 933 - M10X30	Schraube DIN 933 - M10X30	1		
	nut DIN 934 - M10	ecrou DIN 934 - M10	Mutter DIN 934 - M10	1		
	nut DIN 985 - M10	ecrou DIN 985 - M10	Mutter DIN 985 - M10	1		
51	Decanting plate	Tôle de décantation	Absetzbehälter	1	310006248	S
52	Cap	Bouchon	Verschluss	1	310005368	S
53	Locking water tray assy.	Blocage bac à eau complet	Wasserbehälter Blockierung, kompl.	1	310005359	S
	Sheet of blocking	Tôle de blocage	Blockierungsblech	1		
	screw DIN 933 - M10X35	vis DIN 933 - M10X35	Schraube DIN 933 - M10X35	1		
	washer DIN 125 - Ø10,5	rondelle DIN 125 - Ø10,5	Scheibe DIN 125 - Ø10,5	7		
	nut DIN 985 - M10	ecrou DIN 985 - M10	Mutter DIN 985 - M10	2		
	nut DIN 934 - M10	ecrou DIN 934 - M10	Mutter DIN 934 - M10	2		
	screw DIN 933 - M10X65	vis DIN 933 - M10X65	Schraube DIN 933 - M10X65	1		
	nut DIN 315 - M10	ecrou DIN 315 - M10	Mutter DIN 315 - M10	1		

Water pump / Pompe à eau / Wasserpumpe

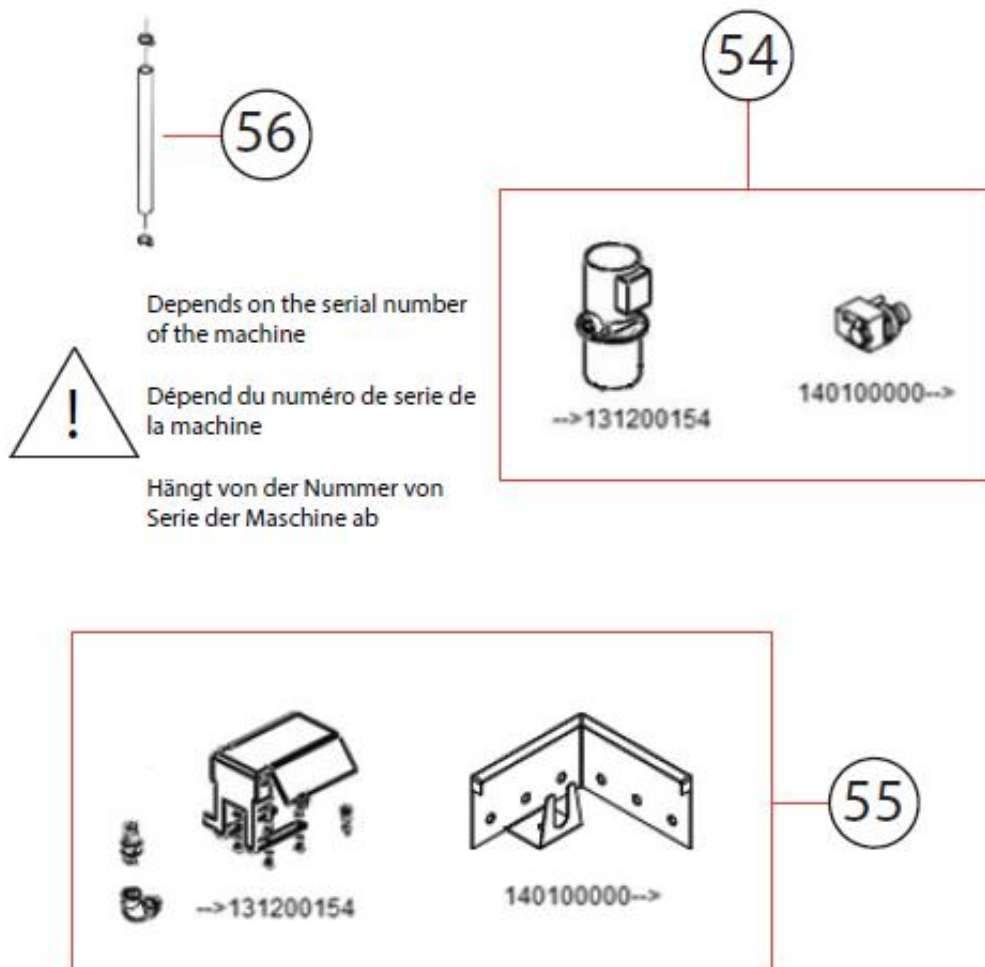

POS.	DESCRIPTION	DESCRIPTION	BESCHREIBUNG	QTY	REF	TYPE
54	Water pump three-phase (serial number up to 140300312)	Pompe à eau triphasée (n° de série jusqu'à 140300312)	Dreiphasenwasserpumpe (Serien Nr. bis 140300312)	1	310388303	S
	Water pump single-phase (serial number from 140300313)	Pompe à eau monophasée (n° de série à partir de 140300313)	Einphasigenwasserpumpe (Serien Nr. ab 140300313)	1	310419887	S
55	Water pump support (serial number up to 140300312)	Support pompe à eau (n° de série jusqu'à 140300312)	Wasserpumpeträger (Serien Nr. bis 140300312)	1	310005005	S
	Water pump support (serial number from 140300313)	Support pompe à eau (n° de série à partir de 140300313)	Wasserpumpeträger (Serien Nr. ab 140300313)	1	510112656	S
56	Pump's pipe	Tuyau pompe	Pumpenrohr	1	510103446	S

Transmission / Transmission / Getriebe

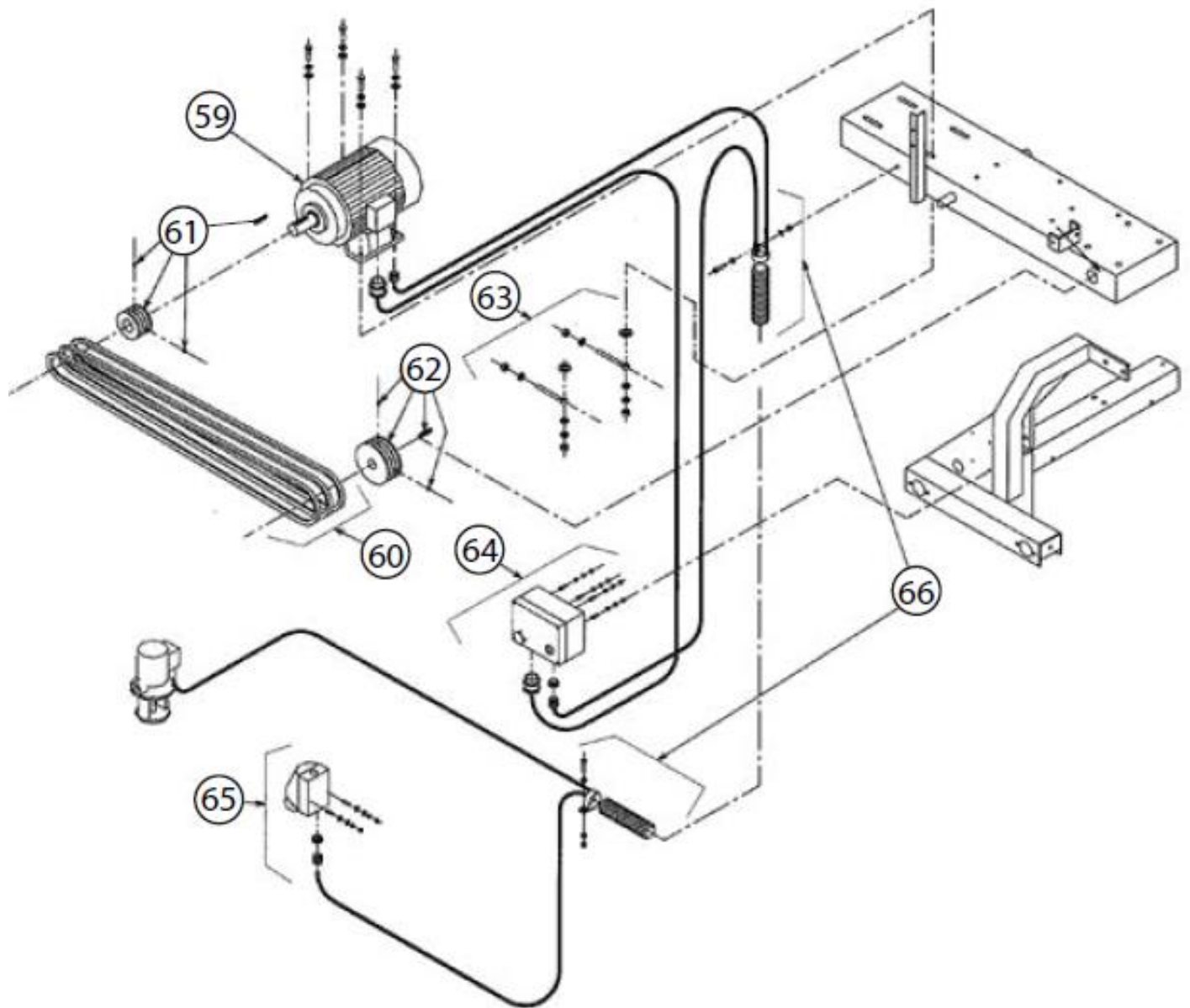

POS.	DESCRIPTION	DESCRIPTION	BESCHREIBUNG	QTY	REF	TYPE
59	Electrical motor 400V kit	Kit moteur électrique 400V	400 V Elektromotor Satz	1	510003853	S
	Electrical motor 400V	Moteur électrique 400V	400 V Elektromotor	1		
	screw DIN 933 – M10X35	vis DIN 933 – M10X35	Schraube DIN 933 – M10X35	2		
	screw DIN 933 – M10X50	vis DIN 933 – M10X50	Schraube DIN 933 – M10X50	2		
	washer DIN 9021 - Ø10,5	rondelle DIN 9021 - Ø10,5	Scheibe DIN 9021 - Ø10,5	10		
	washer DIN 127 - W10	rondelle DIN 127 - W10	Scheibe DIN 127 - W10	4		
	nut DIN 985 - M10	ecrou DIN 985 - M10	Mutter DIN 985 - M10	4		
60	Belt XPA 2000 LW (set of 3)	Courroies XPA 2000 LW (jeu de 3)	XPA 2000 LW Riemen (Satz von 3)	1	310004503	S
61	Motor pulley assy.	Poulie moteur complète	Motorriemenscheibe, kompl.	1	310005306	S
	Motor pulley	Poulie moteur	Motorriemenscheibe	1		
	Wedge	Clavette	Keil	1		
	screw DIN916 – M8X30	vis DIN916 – M8X30	Schraube DIN916 – M8X30	2		
62	Blade shaft pulley assy.	Poulie arbre de meule complète	Schleifscheibenachsescheibe, kompl.	1	310005307	S
	Blade shaft pulley	Poulie arbre de meule	Schleifsachsescheibe	1		
	Wedge	Clavette	Keil	1		
	screw DIN916 – M8X30	vis DIN916 – M8X30	Schraube DIN916 – M8X30	2		
63	Tensioner belt	Tendeur de courroies	Antriebsriemenspanner	1	310002248	S
	screw DIN 444 – M10X130	vis DIN 444 – M10X130	Schraube DIN 444 – M10X130	2		
	screw DIN 931 – M10x50	vis DIN 931 – M10x50	Schraube DIN 931 – M10x50	2		
	lock washer DIN127 - Ø10,3	rondelle DIN127 - Ø10,3	Mutter DIN127 - Ø10,3	2		
	washer DIN 125 - Ø10,5	rondelle DIN 125 - Ø10,5	Scheibe DIN 125 - Ø10,5	8		
	nut DIN 985 - M10	ecrou DIN 985 - M10	Mutter DIN 985 - M10	4		
64	Switch box comp. 400V (serial number up to 1403XXXXX)	Boitier interrupteur complet 400V (n° de série jusqu'à 1403XXXXX)	400V Schaltergehäuse, kompl. (Serien Nr. Bis 1403XXXXX)	1	310007485	S
	Switch box comp. 400V (serial number from 1403XXXXX)	Boitier interrupteur complet 400V (n° de série à partir de 1403XXXXX)	400V Schaltergehäuse, kompl. (Serien Nr ab 1403XXXXX)	1	310005308	S
	Switch box 400V	Boitier interrupteur 400V	400V Schaltergehäuse	1		
	screw DIN 7985 – M5X20	vis DIN 7985 – M5X20	Schraube DIN 7985 – M5X20	4		
	nut DIN 985 - M5	ecrou DIN 985 - M5	Mutter DIN 985 - M5	4		
64	Switch box comp. 400V (serial number from 4502665090000)	Boitier interrupteur complet 400V (n° de série à partir de 4502665090000)	400V Schaltergehäuse, kompl. (Serien Nr ab 4502665090000)	1	310537179	S
	Switch box 400V	Boitier interrupteur 400V	400V Schaltergehäuse	1		
	screw DIN 7985 – M5X20	vis DIN 7985 – M5X20	Schraube DIN 7985 – M5X20	4		
	nut DIN 985 - M5	ecrou DIN 985 - M5	Mutter DIN 985 - M5	4		
65	Plug kit	Prise de courant complète	Steckdose, kompl.	1	310005057	S
	Plug	Prise de courant	Steckdose	1		
	screw DIN 7985 – M5X14	vis DIN 7985 – M5X14	Schraube DIN 7985 – M5X14	2		
	nut DIN 985 - M5	ecrou DIN 985 - M5	Mutter DIN 985 - M5	2		
66	Hose protection kit	Kit Gaine câble	Kabelhülle Satz	1	310002195	S
	Hose protection	Gaine câble	Kabelhülle	1		
	Fixing collar	Bride	Flanche	2		
	screw DIN 933 – M6X16	vis DIN 933 – M6X16	Schraube DIN 933 – M6X16	2		
	nut DIN 985 - M6	ecrou DIN 985 - M6	Mutter DIN 985 - M6	2		

Depth indicator / Indicateur de profondeur / Tiefenlehr

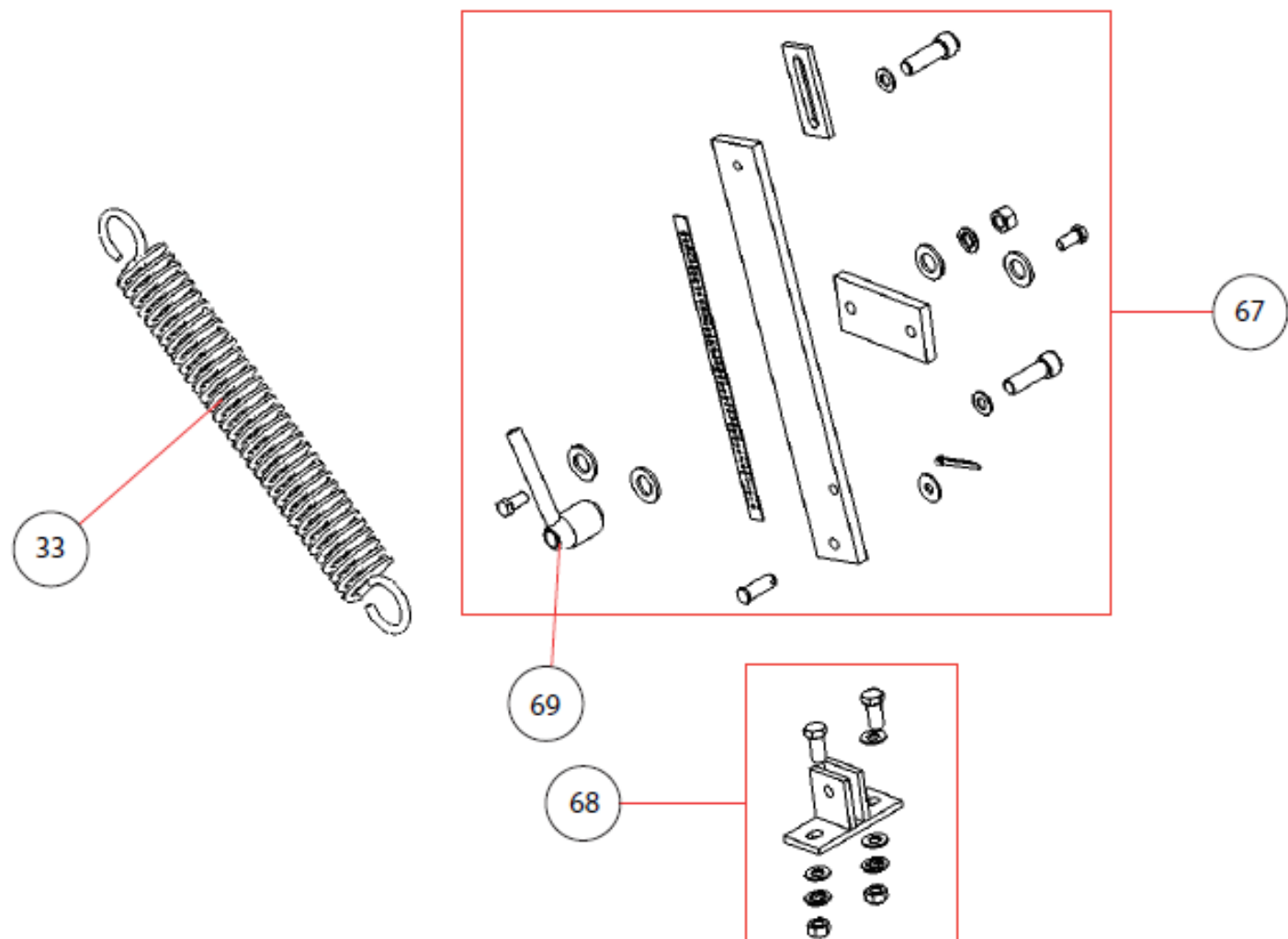

POS.	DESCRIPTION	DESCRIPTION	BESCHREIBUNG	QTY	REF	TYPE
33	Spring	Ressort	Feder	1	310002239	S
	Spring	Ressort	Feder	1		
	screw DIN 444 – M8X70	vis DIN 444 – M8X70	Schraube DIN 444 – M8X70	1		
	washer DIN 9021 - Ø8,4	rondelle DIN 9021 - Ø8,4	Scheibe DIN 9021 - Ø8,4	2		
	washer DIN 127 - W8	rondelle DIN 127 - W8	Scheibe DIN 127 - W8	1		
	nut DIN 934 - M8	ecrou DIN 934 - M8	Mutter DIN 934 - M8	2		
67	Cutting depth indicator assy.	Jauge de profondeur complète	Tiefenlehre, kompl.	1	510103447	S
	Fixing Plate	Plaque de serrage	Spannplatte	1		
	Depth stop	Butée	Anschlag	2		
	screw DIN 912 – M10X25	vis DIN 912 – M10X25	Schraube DIN 912 – M10X25	2		
	screw DIN 933- M12x50	vis DIN 933- M12x50	Schraube DIN 933- M12x50	1		
	washer DIN 9021 - Ø10,5	rondelle DIN 9021 - Ø10,5	Scheibe DIN 9021 - Ø10,5	3		
	screw DIN 933 – M12X55	vis DIN 933 – M12X55	Schraube DIN 933 – M12X55	2		
	washer DIN 127 - W12	rondelle DIN 127 - W12	Scheibe DIN 127 - W12	3		
	nut DIN 985 - M12	ecrou DIN 985 - M12	Mutter DIN 985 - M12	1		
	Fixing handle	Poignée de serrage	Festklemmengriff	1		
	Pin DIN 94 - 2,9x22	Goupille DIN 94 - 2,9x22	Stift DIN 94 - 2,9x22	1		
	Pin DIN EN 22341	Goujon DIN EN 22341 - 10x35	Stiftbolzen DIN EN 22341 - 10x35	1		
68	Fixing depth indicator	Chape jauge de profondeur	Tiefenlehreträger	1	310005309	S
	Fixing depth indicator	Chape	Träger	1		
	screw DIN 933 - M10x30	vis DIN 933 - M10x30	Schraube DIN 933 - M10x30	2		
	washer DIN 9021 - Ø10,5	rondelle DIN 9021 - Ø10,5	Scheibe DIN 9021 - Ø10,5	4		
	washer DIN 127 - W10	rondelle DIN 127 - W10	Scheibe DIN 127 - W10	2		
	nut DIN 985 - M10	ecrou DIN 985 - M10	Mutter DIN 985 - M10	2		
69	Fixing handle	Poignée de serrage	Festklemmengriff	1	510104704	S

Electric box / Boitier électrique / elektrischer Kasten

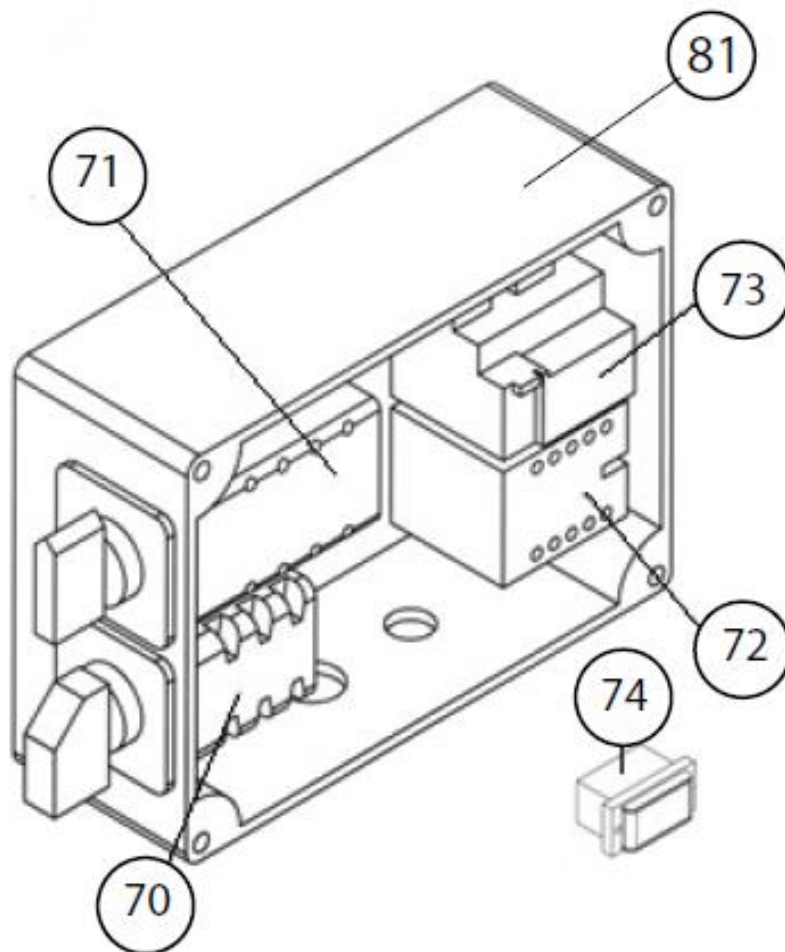

POS.	DESCRIPTION	DESCRIPTION	BESCHREIBUNG	QTY	REF	TYPE
70	Disconnect	Sectionneur	Trennschalter	1	310006622	S
71	Switch, star delta	Kit Interrupteur étoile triangle	Stern Dreieckschalter	1	310006618	S
72	Relay	Kit Relais	Relais	1	310006617	S
73	Thermal relay	Relais thermique	Thermisches Relais	1	310006616	S
74	Thermal protection of pump (Serial Nb -> 1304XXX)	Protection thermique de pompe (N° Serie -> 1304XXX)	Pumpewärmeschutz (Serien Nr -> 1304XXX)	1	310007486	S
74b	Cap for thermal protection of pump (Serial Nb -> 1304XXX)	Cache de protection thermique de pompe (N° Serie -> 1304XXX)	Wärmeschutzabdeckung für Pumpe (Serien Nr -> 1304XXX)	1	310014332	S
81	Plastic box empty for model with thermal protection	Boîte en plastique vide pour modèle avec protection thermique	Plastikkasten leer für Modell mit Wärmeschutz	1	310012297	S
	Plastic box empty for model without thermal protection	Boîte en plastique vide pour modèle sans protection thermique	Plastikkasten leer für Modell ohne Wärmeschutz	1	510131133	S

Electric box / Boitier électrique / elektrischer Kasten

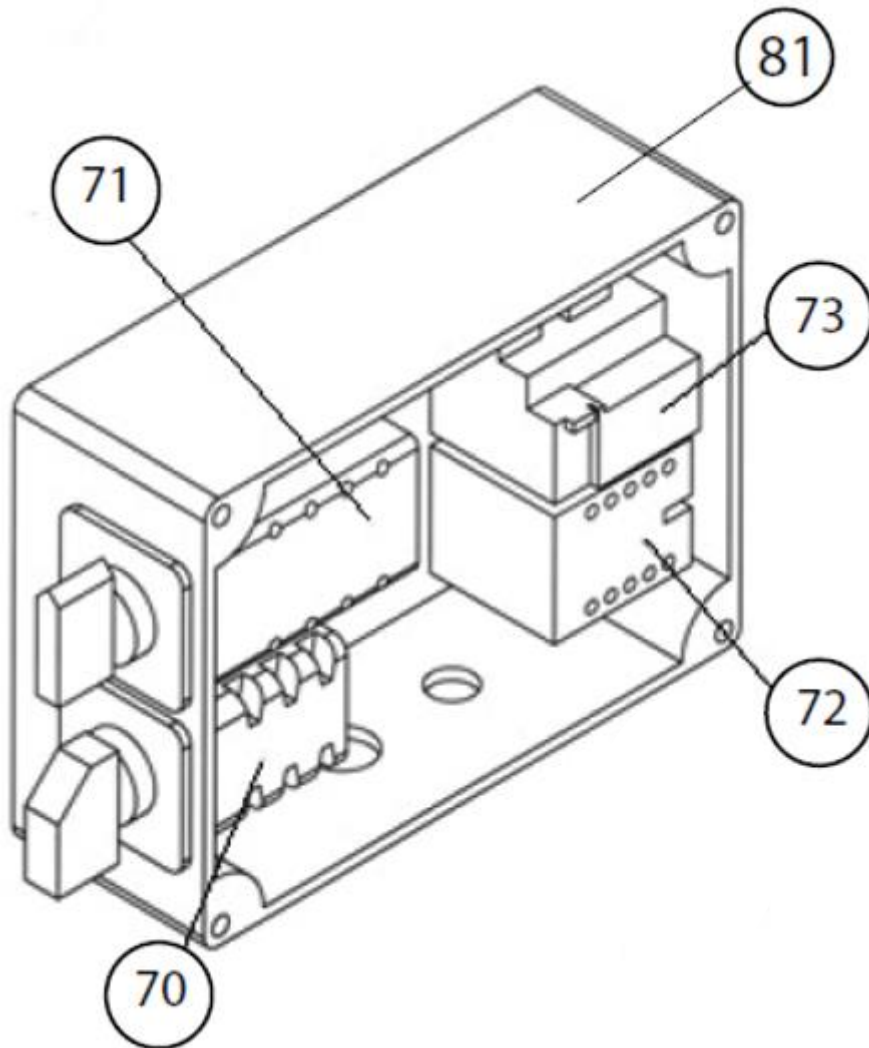

For machine with serial number from 4502665090000

POS.	DESCRIPTION	DESCRIPTION	BESCHREIBUNG	QTY	REF	TYPE
70	Disconnect	Sectionneur	Trennschalter	1	310534506	S
71	Switch, star delta	Kit Interrupteur étoile triangle	Stern Dreieckschalter	1	310534507	S
72	Relay	Kit Relais	Relais	1	310534508	S
73	Thermal relay	Relais thermique	Thermisches Relais	1	310534511	S
81	Plastic box empty	Boîte en plastique vide	Plastikkasten leer	1	310534510	S

Motor / Moteur / Motor

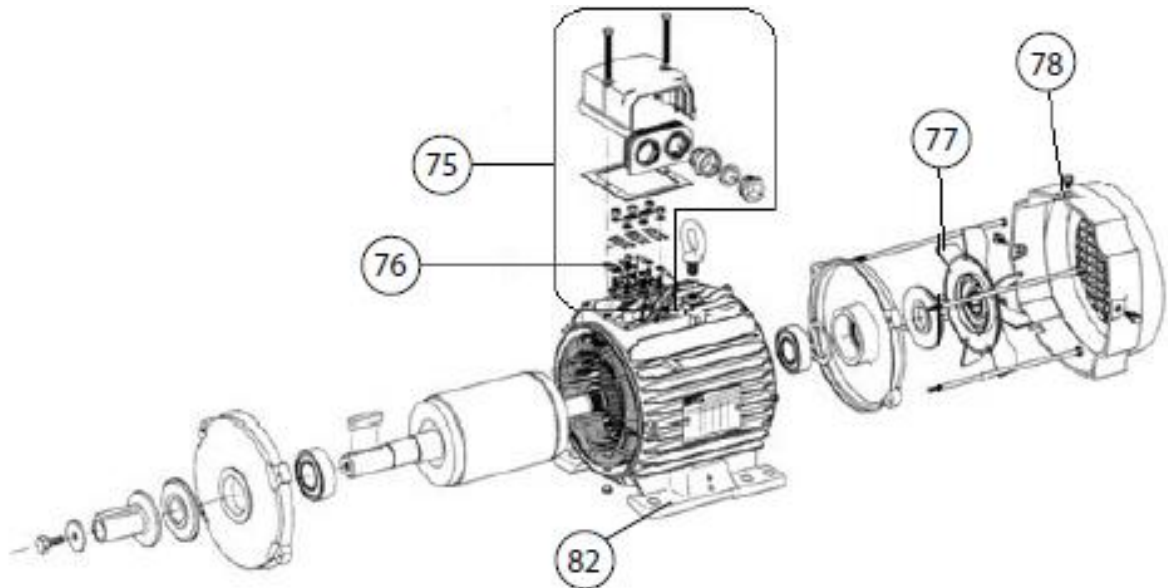

Moteur Leroy Somer

POS.	DESCRIPTION	DESCRIPTION	BESCHREIBUNG	QTY	REF	TYPE
75	Terminal box MOTOR LEROY SOMER	Boite à bornes MOTEUR LEROY SOMER	Anschlusskasten MOTOR LEROY SOMER	1	510128605	S
76	Terminal MOTOR LEROY SOMER	Bornier MOTEUR LEROY SOMER	Terminal MOTOR LEROY SOMER	1	510128608	S
77	Ventilator MOTOR LEROY SOMER	Ventilateur MOTEUR LEROY SOMER	Ventilator MOTOR LEROY SOMER	1	510128578	S
78	Ventilator cover MOTOR LEROY SOMER	Capot ventilateur MOTEUR LEROY SOMER	Ventilatorhaube MOTOR LEROY SOMER	1	510128579	S

Moteurs Wat

POS.	DESCRIPTION	DESCRIPTION	BESCHREIBUNG	QTY	REF	TYPE
75	Terminal box MOTOR WAT	Boite à bornes MOTEUR WAT	Anschlusskasten MOTOR WAT	1	510128606	S
76	Terminal MOTOR WAT	Bornier MOTEUR WAT	Terminal MOTOR WAT	1	510128609	S
77	Ventilator MOTOR WAT until 19029565	Ventilateur MOTEUR WAT jusqu'à 19029565	Ventilator MOTOR WAT bis 19029565	1	510128596	S
77 bis	Ventilator MOTOR WAT from 19029566	Ventilateur MOTEUR WAT à partir de 19029566	Ventilator MOTOR WAT ab 19029566	1	310540487	S
78	Ventilator cover MOTOR WAT until 19029565	Capot ventilateur MOTEUR WAT jusqu'à 19029565	Ventilatorhaube MOTOR WAT bis 19029565	1	510128598	S
78 bis	Ventilator cover MOTOR WAT from 19029566	Capot ventilateur MOTEUR WAT à partir de 19029566	Ventilatorhaube MOTOR WAT ab 19029566	1	310540489	S
82	support MOTOR WAT until 19029565	Support MOTEUR WAT jusqu'à 19029565	Unterstützung MOTOR WAT bis 19029565	2	510141174	S
82 bis	support MOTOR WAT from 19029566	Support MOTEUR WAT à partir de 19029566	Unterstützung MOTOR WAT ab 19029566	2	310540490	S

Motor / Moteur / Motor

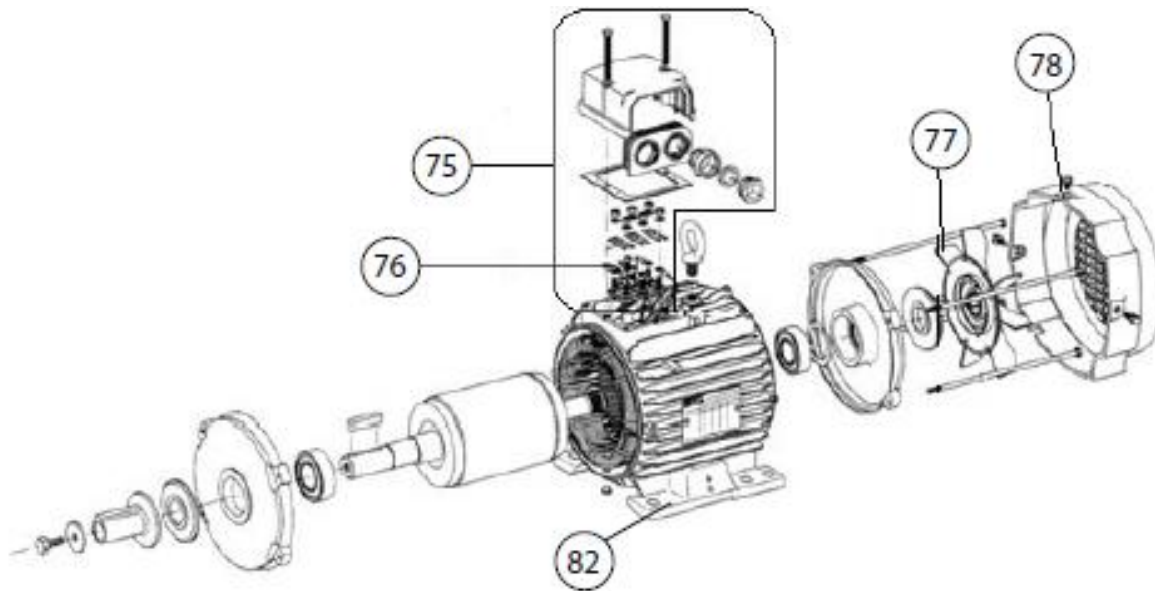

Moteur New Tech

POS.	DESCRIPTION	DESCRIPTION	BESCHREIBUNG	QTY	REF	TYPE
75	Terminal box MOTOR NEW TECH	Boite à bornes MOTEUR NEW TECH	Anschlusskasten MOTOR NEW TECH	1	510128604	S
76	Terminal MOTOR NEW TECH	Bornier MOTEUR NEW TECH	Terminal MOTOR NEW TECH	1	510128607	S
77	Ventilator MOTOR NEW TECH	Ventilateur MOTEUR NEW TECH	Ventilator MOTOR NEW TECH	1	510107983	S
78	Ventilator cover MOTOR NEW TECH	Capot ventilateur MOTEUR NEW TECH	Ventilatorhaube MOTOR NEW TECH	1	510107920	S
82	Support MOTOR NEW TECH	Spport MOTEUR NEW TECH	Unterstützung MOTOR NEW TECH	2	310537274	S

Moteur Able

POS.	DESCRIPTION	DESCRIPTION	BESCHREIBUNG	QTY	REF	TYPE
75	TERMINAL BOX (ABLE MSHE132M-4) J900/1000	Boite à bornes (ABLE MSHE132M-4) J900/1000	Anschlusskasten (ABLE MSHE132M-4) J900/1000	1	510141163	S
76	TERMINAL BLOCK(ABLE MSHE132M-4)J900/1000	Bornier (ABLE MSHE132M-4) J900/1000	Terminal (ABLE MSHE132M-4) J900/1000	1	510141224	S
77	FAN (ABLE MSHE132M-4) JUMBO900/1000	Ventilateur (ABLE MSHE132M-4) J900/1000	Ventilator (ABLE MSHE132M-4) J900/1000	1	510141225	S
78	FAN COVER (ABLE MSHE132M-4)JUMBO900/1000	Capot ventilateur (ABLE MSHE132M-4) J900/1000	Ventilatorhaube (ABLE MSHE132M-4) J900/1000	1	510141226	S

Jumbo 900 stickers kit:

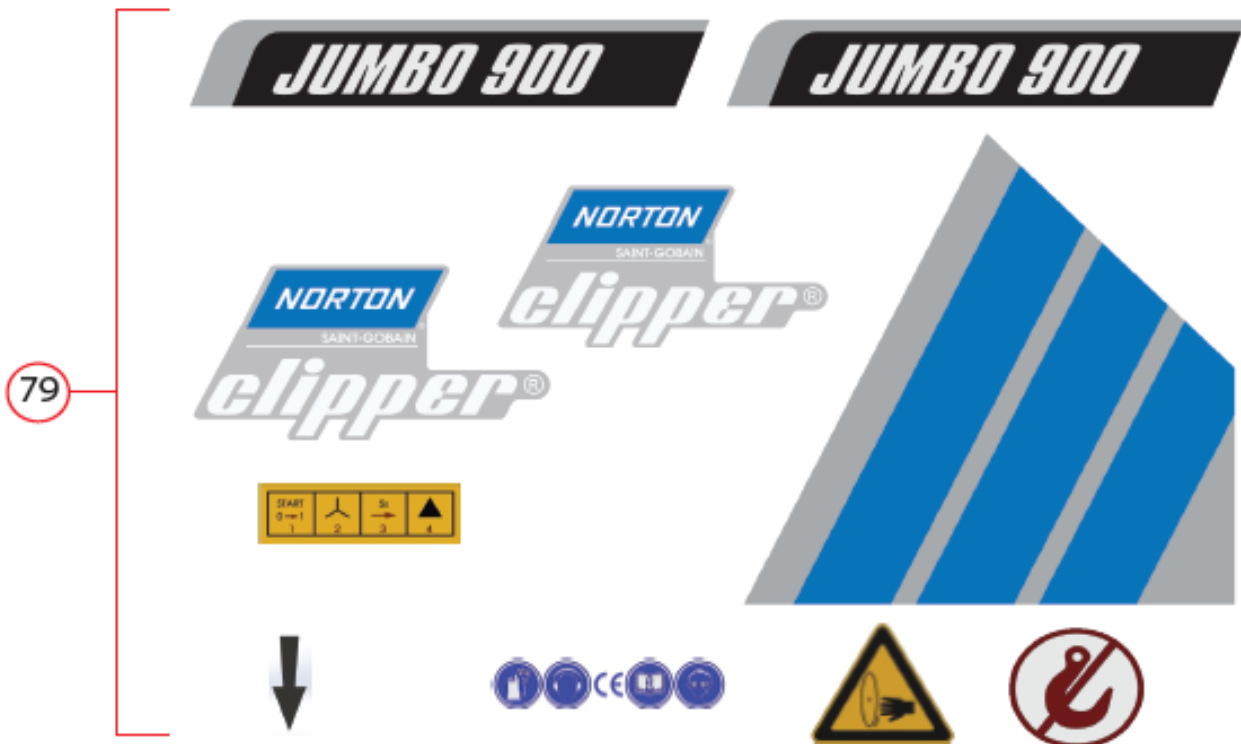

Jumbo 1000 stickers kit:

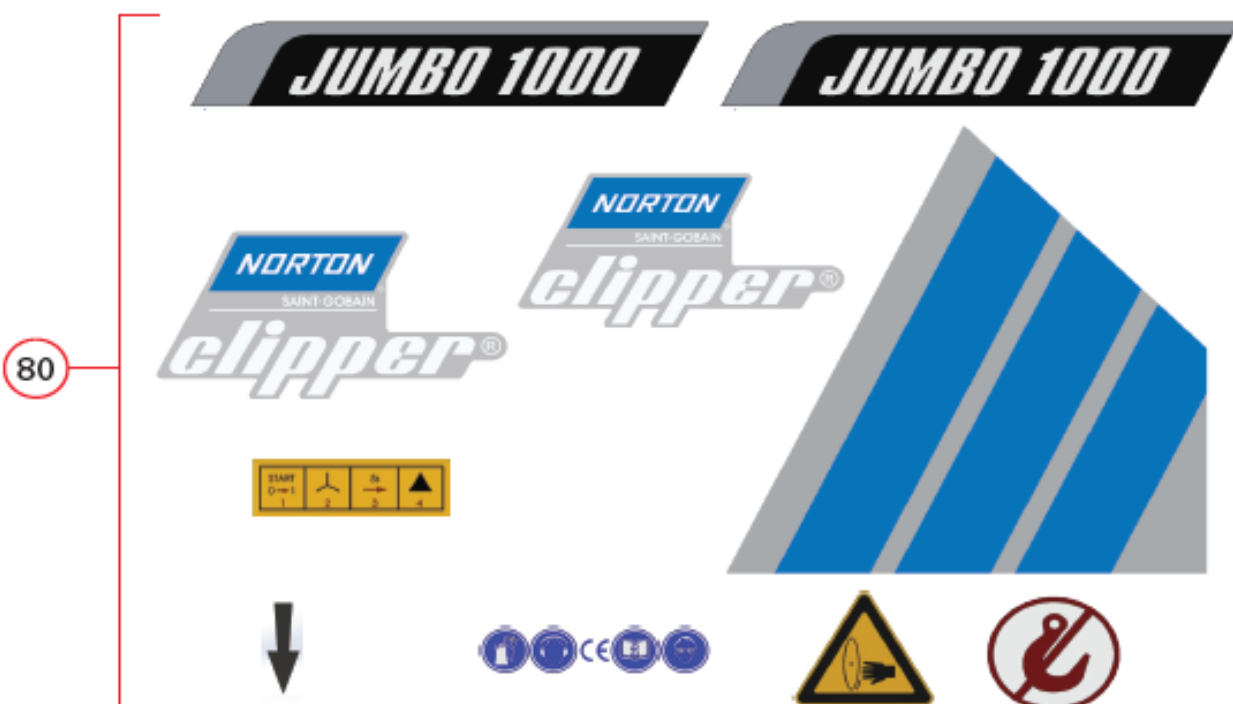

POS.	DESCRIPTION	DESCRIPTION	BESCHREIBUNG	QTY	REF	TYPE
79	Sticker kit Jumbo900	Kit d'autocollants Jumbo900	Jumbo 900 Aufkleber Satz	1	510131234	S
	White arrow	Flèche blanche	Weißer Pfeil	1		
	4 pictograms	4 pictogrammes	4 Piktogramme	1		
	Right side	Flanc droit	Rechte Flanke	1		
	Left side	Flanc gauche	Linke Flanke	1		
	Norton Clipper Logo Blade guard	Norton Clipper carter de disque	Norton Clipper Scheibegehäuse	1		
	Norton Clipper Logo Blade guard back	Norton Clipper carter de disque arrière	Norton Clipper Hinterplattegehäuse	1		
	Risk of hand cut	Risque de coupure main	Gefahr von Schnittverletzungen	1		
	Prohibited hook	Crochet interdit	Haken verboten	1		
	Instructions driving starting	Instructions démarrage moteur	Motorstartanweisungen	1		
80	Sticker kit Jumbo1000	Kit d'autocollants Jumbo1000	Jumbo 1000 Aufkleber Satz	1	510131235	S
	White arrow	Flèche blanche	Weißer Pfeil	1		
	4 pictograms	4 pictogrammes	4 Piktogramme	1		
	Right side	Flanc droit	Rechte Flanke	1		
	Left side	Flanc gauche	Linke Flanke	1		
	Norton Clipper Logo Blade guard	Norton Clipper carter de disque	Norton Clipper Scheibegehäuse	1		
	Norton Clipper Logo Blade guard back	Norton Clipper carter de disque arrière	Norton Clipper Hinterplattegehäuse	1		
	Risk of hand cut	Risque de coupure main	Gefahr von Schnittverletzungen	1		
	Prohibited hook	Crochet interdit	Haken verboten	1		
	Instructions driving starting	Instructions démarrage moteur	Motorstartanweisungen	1		

SAINT-GOBAIN ABRASIVES
 INDUSTRIEWEG 21
 9420 ERPE-MERE
 BELGIUM
 TEL: +32(0) 2 267 21 00

SAINT-GOBAIN ABRASIVES, S.R.O.
 POČERNICKÁ 272/96, MALEŠICE
 108 00 PRAHA 10
 CZECH REPUBLIC
 TEL: +420 255 719 326
 FAX: +420 255 719 321

SAINT-GOBAIN ABRASIVES A/S
 DYBENDALSVEJENGET 2,
 DK-2630 TAASTRUP
 DENMARK
 TEL: +45 4675 5244

SAINT-GOBAIN ABRASIVES MIDDLE EAST
 JEBEL ALI FREE ZONE,
 PLOT NO. S10817
 PO BOX 261484, DUBAI •
 UNITED ARAB EMIRATES
 TEL: +971 (4) 8011 800
 FAX: +971 (4) 8011 801

SAINT-GOBAIN ABRASIFS
 RUE DE L'AMBASSADEUR - B.P.8
 78 702 CONFLANS CEDEX
 FRANCE
 TEL: +33 (0) 1 34 90 40 00
 FAX: +33 (0) 1 39 19 89 56

SAINT-GOBAIN ABRASIVES GMBH
 BIRKENSTRASSE 45-49
 D-50389 WESSELING
 GERMANY
 TEL: +49 (0) 2236 703-1
 +49 (0) 2236 8996-0
 +49 (0) 2236 8911-0
 FAX: +49 (0) 2236 703-367
 +49 (0) 2236 8996-10
 +49 (0) 2236 8911-30

FÜR DEN FACHHANDEL
 ÖSTERREICH
 TEL: +43 (00) 662 430 076

SAINT-GOBAIN ABRASIVES KFT.
 1225 BUDAPEST
 BÁNYALÉG U. 60/B.
 HUNGARY
 TEL: +36 1 371 22 50
 FAX: +36 1 371 22 55

SAINT-GOBAIN ABRASIVI S.P.A
 VIA PER CESANO BOSCONI 4
 I-20094 CORSICO MILANO
 ITALY
 TEL: +39 02 44 851
 FAX: +39 02 44 78 266

SAINT-GOBAIN ABRASIVES S.A.
 190 RUE J.F. KENNEDY
 L-4930 BASCHARAGE
 GRAND DUCHE DE LUXEMBOURG
 TEL: +352 50 401 1
 FAX: +331 83 717 792
 NO. VERT (FRANCE): 0800 906 903

SAINT-GOBAIN ABRASIFS, S.A.
 2 ALLÉE DES FIGUIERS
 AIN SEBÂÂ - CASABLANCA
 MOROCCO
 TEL: +212 5 22 66 57 31
 FAX: +212 5 22 35 09 65

SAINT-GOBAIN ABRASIVES BV
 GROENLOSEWEG 28
 7151 HW EIBERGEN
 P.O. BOX 10
 7150 AA EIBERGEN
 THE NETHERLANDS
 TEL: +31 545 466466
 FAX: +31 545 474605

SAINT-GOBAIN ABRASIVES AS
 POSTBOKS 11, ALNABRU, 0614 OSLO
 BROBEKKVEIEN 84,
 0582 OSLO • NORWAY
 TEL: +47 63 87 06 00
 FAX: +47 63 87 06 01

SAINT-GOBAIN HPM POLSKA SP. Z O.O.
 UL. NORTON 1,
 62-600 KOŁO • POLAND
 TEL: +48 63 26 17 100
 FAX: +48 63 27 20 401

SAINT-GOBAIN ABRASIVOS, L. DA
 ZONA INDUSTRIAL DA MAIA
 I-SECTOR VIII, NO. 122
 APARTADO 6050
 4476 - 908 MAIA
 PORTUGAL
 TEL: +351 229 437 940
 FAX: +351 229 437 949

SAINT-GOBAIN GLASS
 BUSINESS UNIT ABRASIVI
 PUNCT DE LUCRU : LOC.VETIS, JUD.
 SATU MARE 447355
 STR. CAREIULUI 11
 PARC INDUSTRIAL RENOVATIO
 ROMANIA
 TEL: +40 261 839 709
 FAX: +40 261 839 710

SG HPM RUS
 58, F. ENGELS STR.
 STROENIE 2
 105082 MOSCOW
 RUSSIA
 TEL: +74 955 408 355
 FAX: +74 959 373 224

SAINT-GOBAIN
 ABRASIVES (PTY) LTD
 2 MONTEER ROAD
 ISANDO 1600
 P.O. BOX 67
 SOUTH AFRICA
 TEL: +27 11 961 2000
 FAX: +27 11 961 2184/5

SAINT-GOBAIN ABRASIVOS, S.A.
 CTRA. DE GUIPÚZCOA, KM. 7,5
 E-31195 BERRIOPLANO (NAVARRA)
 SPAIN
 TEL: +34 948 306 000
 FAX: +34 948 306 042

SAINT GOBAIN ABRASIVES AB
 GÅRDSFOGDEVÄGEN 18A
 168 66 BROMMA • SVERIGE
 SWEDEN
 TEL: +46 8 580 881 00
 FAX: +46 8 580 881 30

SAINT-GOBAIN INOVATIF MALZEMELER VE
 ASINDIRICI SAN. TIC. AS.
 ALTAYÇEŞME MAH. ÇAMLI SOK. NO:21 ESAS
 OFISPAK KAT:9 34843
 MALTEPE, İSTANBUL • TURKEY
 TEL: 0090-216-217 12 50
 FAX: 0090-216-442 40 74

SAINT-GOBAIN ABRASIVES LTD.
 DOXEY RD
 STAFFORD
 ST16 1EA
 UNITED KINGDOM
 TEL: +44 1785 222 000
 FAX: +44 1785 213 487



Saint-Gobain Abrasifs
 190 Rue J.F. Kennedy
 L-4930 Bascharage
 Grand Duché de Luxembourg
 Tel: +331 83 717 792
 Fax: +352 50 16 33
 no. vert (France) 0800 906 903